

THERMAL DYNAMICS®



Replacement Plasma Torches

Hand Torches

SL60™

SL100™



1Torch™

with SURELOK™ Technology

Machine Torches

SL100™



1Torch™

with SURELOK™ Technology



Instructions for:

Torches
Adapter Kits
Lead Extensions
Remote Interface
Replacement Parts

Torch and Adapter installations
on most Manufacturers' Units

- Esab
- Hypertherm
- L-Tec
- Hobart
- Lincoln
- Smith
- Miller
- Harris

...and more!

Master Guide

Section I

Torches

Contents

SL60/SL100 RPT

1Torch™

with SURELOK® Technology

Torch and Lead Selection

Listed below are the Torch and Lead selection charts for the SL60™ and SL100™ Hand 1Torch RPT torches.



ORDERING INFORMATION

Hand Torches

SL60™

Light/Medium Duty Torch
20-60 Amps



SL100™

Medium/Heavy Duty Torch
30-100 Amps



CAT NO. DESCRIPTION

A Standard RPT (O2B) Torch Connection



Torch & Leads

SL60 Hand Torch (20-60 Amps)

7-5200	SL60, 75°, 20' (6.1m) Torch/Leads
7-5201	SL60, 75°, 50' (15.2m) Torch/Leads

CAT NO. DESCRIPTION

A Standard RPT (O2B) Torch Connection



Torch & Leads

SL100 Hand Torch (30-100 Amps)

7-5202	SL100, 75°, 20' (6.1m) Torch/Leads
7-5203	SL100, 75°, 50' (15.2m) Torch/Leads

B ATC™ Torch Connection



Torch & Leads

SL60 Hand Torch w/ ATC (20-60 Amps)

7-5204	*SL60, 75°, 20' (6.1m) Torch/Leads
7-5205	*SL60, 75°, 50' (15.2m) Torch/Leads

ATC™ Adapter Kit

ATC Receptacle Adapter

7-5207	ATC Receptacle Connector
--------	--------------------------

* This receptacle adapter is required for each power supply using an ATC torch connection. This is connected to the torch adapter kit specific to each power supply.



ATC™ Lead Extensions

Lead Extensions - Standard

7-7544	15' (4.5m) Lead Extension
7-7545	25' (7.6m) Lead Extension
7-7552	50' (15.2m) Lead Extension

B ATC™ Torch Connection



Torch & Leads

SL100 Hand Torch w/ ATC (30-100 Amps)

7-5206	*SL100, 75°, 20' (6.1m) Torch/Leads
7-5208	*SL100, 75°, 50' (15.2m) Torch/Leads

ATC™ Adapter Kit

ATC Receptacle Adapter

7-5207	ATC Receptacle Connector
--------	--------------------------

* This receptacle adapter is required for each power supply using an ATC torch connection. This is connected to the torch adapter kit specific to each power supply.



ATC™ Lead Extensions

Lead Extensions - Standard

7-7544	15' (4.5m) Lead Extension
7-7545	25' (7.6m) Lead Extension
7-7552	50' (15.2m) Lead Extension

NOTES: *Total lead length including torch and extension(s), should not exceed the maximum length specified by the power supply manufacturer.

SL60 and SL100 RPT Replacement Plasma Cutting Hand Torches

Installation and Operation Instructions

General Information

The 1Torch™ SL60 and SL100 Torches work with most plasma cutting power supplies. The Torches are equipped with either O2B connectors or the Thermal Dynamics ATC connector and are connected using various Adapter Kits sold separately.

A label on the torch handle indicates the torch model number. SL60 Torches provide cutting capabilities of up to 60 amperes. SL100 Torches provide cutting capabilities of up to 100 amperes. The torches use compressed air as both the plasma and secondary gas.

The torches are suitable for drag cutting (with the torch tip in contact with the workpiece, at up to 40 Amps output); 40 - 100 Amp shielded drag cutting (with shielded torch parts (cap, etc.) in contact with the workpiece); standoff cutting; or gouging.

Refer to the Complete Assembly Replacement page for configurations and catalog numbers.

These instructions are important for the proper installation of the Torches. Read the instructions thoroughly before attempting the installation. Keep these instructions for reference.

Supplied Parts

The Replacement Torches include:

- Torch With Leads - 1 each
- Installation Instructions - 1 each
- Consumables (Installed on the Torch): Electrode, Starter Cartridge, Tip, Shield Cup Body and Drag Shield Cap
- Standard Shield Cup

NOTE

The consumable parts installed in the Torch may not necessarily be optimized for your Power Supply or cutting application. For best results, refer to the selection chart in this manual to choose the proper consumables.

Options

The following options are available. Refer to the complete assembly replacement list for catalog numbers.

- ATC Adapter Kit (for Torches with ATC connections)
- Leads extensions (for Torches with ATC connections)
- Cutting Guide Kits
- Leather Leads Covers

Torch Specifications

A. Torch Configuration

The torch head is at 75° to the torch handle. The torch includes a torch handle and torch trigger assembly.

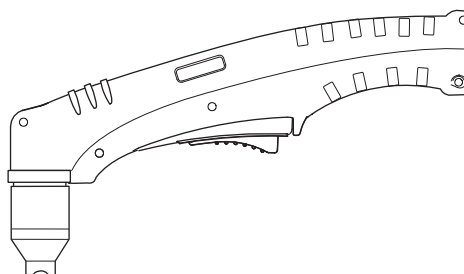

A-03440

B. Torch Leads Lengths

- 20 foot / 6.1 m, or 50 foot / 15.2 m

For torches with ATC Connectors, leads extensions are available to extend the leads to a maximum of 50 feet / 15.2 m. Total leads lengths must not exceed the power supply manufacturer's recommendations.

C. Current Rating (Refer to Note)

Current Ratings	
SL60 Torch & Leads	Up to 60 Amps, DC, Straight Polarity
SL100 Torch & Leads	Up to 100 Amps, DC, Straight Polarity

NOTE

Power Supply characteristics will determine material thickness range.

D. Torch Ratings

SL60 Torch Ratings	
Ambient Temperature	104° F 40° C
Duty Cycle	100% @ 60 Amps @ 400 scfh
Maximum Current	60 Amps
Voltage (V _{peak})	500V
Arc Striking Voltage	7kV

SL100 Torch Ratings	
Ambient Temperature	104° F 40° C
Duty Cycle	100% @ 100 Amps @ 400 scfh
Maximum Current	100 Amps
Voltage (V _{peak})	500V
Arc Striking Voltage	7kV

E. Type of Cooling

Combination of ambient air and gas stream through torch.

F. Gas Requirements

SL60 and SL100 Torch Gas Specifications	
Gas (Plasma and Secondary)	Compressed Air
Operating Pressure <i>Refer to NOTE</i>	60 - 75 psi 4.1 - 5.2 bar
Maximum Input Pressure	125 psi / 8.6 bar
Gas Flow (Cutting and Gouging)	300 - 500 scfh 142 - 235 lph



WARNING

This torch is not to be used with oxygen (O₂).

NOTE

Operating pressure varies with torch model, operating amperage, and torch leads length. Refer to gas pressure settings charts for each model.

G. Direct Contact Hazard

For exposed tip the recommended standoff is 1/8" - 1/4" (3 - 6.4 mm).

H. Parts - In - Place (PIP) Circuit - 12 vdc

The torch and leads include circuitry called Parts - In - Place (PIP). This circuit includes a switch located at the torch head. The shield cup closes this switch when properly installed. The torch will not operate if this switch is open.

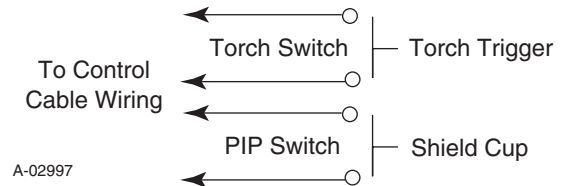

Connecting Torch

There are two types of connection for the Torch Leads. One type uses the Thermal Dynamics ATC connector. The other uses O2B connections for gas and circuitry. Both types require an adapter kit sold separately.

ATC Connectors

Follow the instructions provided with the adapter kit to connect the adapter to the power supply.

Inspect the halves of the ATC Connector. Align the male connector with the female receptacle and push them together by hand until they seat fully. Turn the Locking Ring until it pulls the halves of the connector together fully. Do not use tools to tighten the connector. If there is any resistance to the ring turning, pull the halves of the connector apart, realign the inner components, ensure that the threaded components are aligned, and push the halves of the connector together again.

O2B Connectors

Leads with O2B connectors are connected to the power supply using adapter kits sold separately. Follow the instructions provided with the adapter kit to connect the gas and electrical lines to the power supply.

Spare Parts Label

The parts kit provided with this torch includes an adhesive label. Select the small perforated section showing the appropriate pressure setting for the amperage output and leads length to be used with this torch. Refer to the charts. Apply this section in the 'Gas Supply' area of the label under the 'Recommended operating pressure' text. Discard any pressure setting sections of the label that will not be used. Apply the large label to the power supply, where the operator can see it for easy reference.

Torch Parts Selection

Refer to the **Consumables Selection Chart** for the various torch parts for the application and operation.



WARNINGS

Disconnect primary power to the system before disassembling the torch or torch leads.

DO NOT touch any internal torch parts while the AC indicator light of the Power Supply is ON.

The shield cup (or shield cup body and end cap or deflector) holds the tip and starter cartridge in place. Position the torch with the shield cup facing upward to keep the tip and starter cartridge from falling out when the cup is removed.

Change the torch parts as follows:

1. Unscrew and remove the shield cup from the torch head.

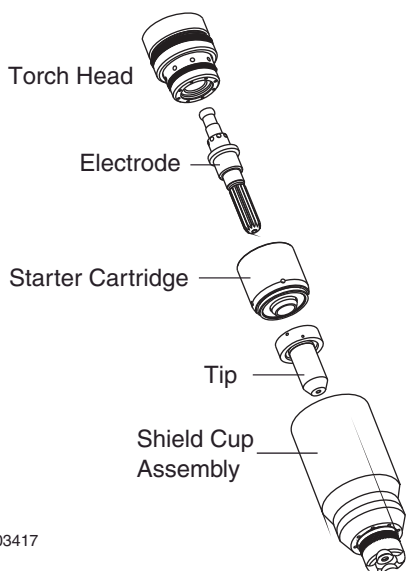

A-03417

2. Tilt the torch head to remove the tip and starter cartridge.
3. Fit the desired starter cartridge and tip onto the electrode.

NOTE

Refer to the consumables selection chart for the proper combination of torch parts, including shield cups and caps.

4. Hand tighten the shield cup until it is seated on the torch head. **Do not use tools to tighten the cup.** If resistance is felt when installing the cup, check the threads before proceeding.

NOTE

When operating the torch in a normal condition, a small amount of gas vents through the gap between the shield cup and torch handle. Do not attempt to over tighten the shield cup as irreparable damage to internal components may result.

Gouging Parts Selection

Select gouging tips according to the desired gouge profile. Gouging parameters shown are based on a 35° approach angle.

Gouging Profiles		
	Depth	Width
Tip A	Shallow	Narrow
Tip B	Deep	Narrow
Tip C	Moderate	Moderate
Tip D	Shallow	Wide

Operating Gas Pressure

Set gas pressure at the power supply regulator according to the following charts. These charts are a guide only; adjust as necessary for best performance.

SL60 Gas Pressure Settings		
	Leads Length	
Tip	20' / 6.1 m	50' / 15.2 m
30A, 40A, 50/55A, 60A	65 psi / 4.5 bar	75 psi / 5.2 bar

SL100 Gas Pressure Settings		
	Leads Length	
Tip	Up to 25' / 7.6 m	50' / 15.2 m
30A, 40A, 50/55A, 60A, 70A, 80A	60 psi / 4.1 bar	65 psi / 4.5 bar
90 / 100 A	65 psi / 4.5 bar	70 psi / 5.2 bar

Cutting or Gouging

The torch can be held comfortably in one hand or steadied with two hands. Choose the holding technique that feels most comfortable and allows good control and movement.

Sequence of Operation

1. Turn on power and adjust gas pressure on the Power Supply pressure gauge. Refer to the charts for optimum pressure settings for the combination of torch tip and total leads lengths (including extensions) in use.
2. Adjust current output on the Power Supply to match the selected tip and attach the work clamp firmly to the work.



WARNING

Maximum current is 60 Amps for SL60 Torches, or 100 Amps for SL100 Torches. Operation of this torch at higher outputs may damage the torch, the leads, the components, or the Power Supply. DO NOT operate the SL60 torch at more than 60 Amps, or the SL100 at more than 100 Amps.

CAUTION

Do not operate the torch with the torch tip in contact with the work at outputs greater than 40 amps. Drag cutting at higher output currents can cause irreparable damage to the torch parts. Use only shielded parts at output currents higher than 40 amps.

3. Hold the torch away from your body.
4. Slide the trigger release toward the back of the torch handle while simultaneously squeezing the trigger. The pilot arc will start.

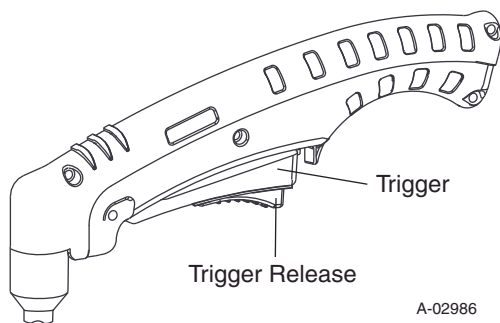

5. Bring the torch within transfer distance to the work. The main arc will transfer to the work, and the pilot arc will shut off.

NOTE

The gas preflow and postflow are a characteristic of the power supply and not a function of the torch.

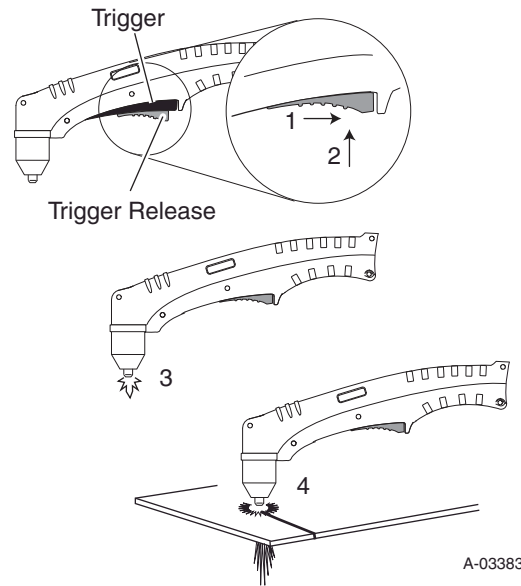

6. Cut as usual. Simply release the trigger assembly to stop cutting.
7. Follow normal recommended cutting practices as provided in the power supply operator's manual.

NOTE

When the shield cup is properly installed, there is a slight gap between the shield cup and the torch handle. Gas vents through this gap as part of normal operation. Do not attempt to force the shield cup to close this gap. Forcing the shield cup against the torch head or torch handle can damage components.

Common Operating Faults

The following are the more common cutting faults and the possible causes:

1. Insufficient Penetration

- a. Cutting speed too fast
- b. Torch tilted too much
- c. Metal too thick
- d. Worn torch parts
- e. Cutting current too low
- f. Non - Genuine Thermal Dynamics Parts

2. Main Arc Extinguishes

- a. Cutting speed too slow
- b. Torch standoff too high from workpiece
- c. Cutting current too high
- d. Work cable disconnected
- e. Worn torch parts
- f. Non - Genuine Thermal Dynamics Parts

3. Excessive Dross Formation

- a. Cutting speed too slow
- b. Torch standoff too high from workpiece
- c. Worn torch parts
- d. Improper cutting current
- e. Non - Genuine Thermal Dynamics Parts

4. Short Torch Parts Life

- a. Oil or moisture in air source
- b. Exceeding system capability (material too thick)
- c. Excessive pilot arc time
- d. Gas pressure too low
- e. Improperly assembled torch
- f. Non - Genuine Thermal Dynamics Parts

5. Difficult Starting

- a. Worn torch consumables
- b. Non - Genuine Thermal Dynamics Parts

Inspection and Replacement of Consumable Torch Parts



WARNINGS

Disconnect primary power to the system before disassembling the torch or torch leads.

DO NOT touch any internal torch parts while the AC indicator light of the Power Supply is ON.

Unthread the shield cup assembly to remove the consumable torch parts.

1. Inspect the cup for damage. Wipe it clean or replace if damaged. Slag built up on the shield cup that cannot be removed may affect the performance of the system.

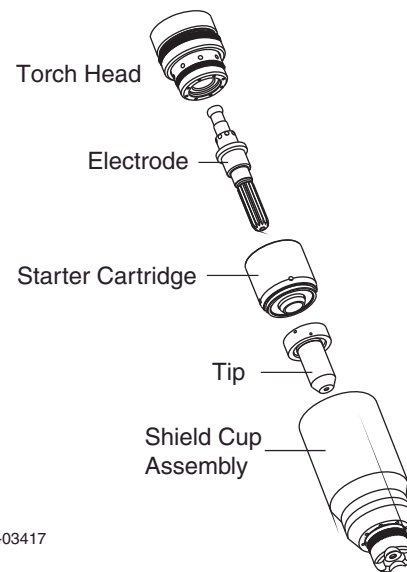

A-03417

2. Check the tip for excessive wear (indicated by an elongated or oversized orifice). Clean or replace the tip if necessary.

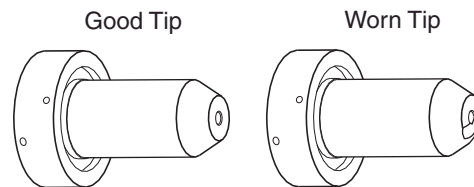

A-03406

3. Check the starter cartridge for excessive wear, plugged gas holes, discoloration, and for free movement of the lower end plate. Replace if necessary.

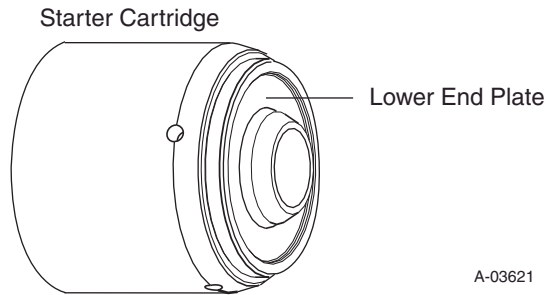

4. Check the end of the electrode for excessive wear.

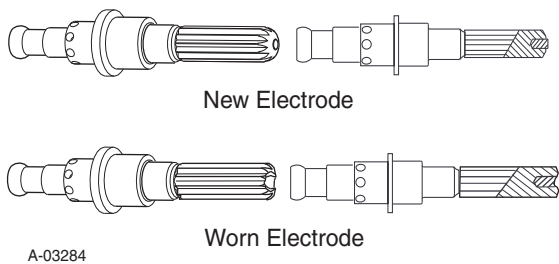

5. Reinstall the Electrode by pushing it straight into the torch head until it clicks.



WARNINGS

Refer to the consumables selection charts for the proper combination of torch parts, including shield cups and shield caps.

The use of any consumable parts other than those specified by the Manufacturer may cause irreparable damage to the torch head.

6. Reinstall the starter cartridge and tip into the torch head.
7. Hand tighten the shield cup until it is seated on the torch head. If resistance is felt when installing the cup, check the threads before proceeding.

CAUTION

When operating the torch in a normal condition, a small amount of gas vents through the gap between the shield cup and torch handle. Do not attempt to over tighten the shield cup as irreparable damage to internal components may result.

Torch Consumables

The illustrations show all consumable parts for the SL60 and SL100 torches. Refer to the Appendix pages covering the power supply being used to ensure proper selection for the application.

Various front - end torch parts are available for different applications.

Use the single - piece shield cup for general purpose cutting operations with the torch tip in contact with the work (up to 40 amps). This is the preferred method of cutting sheet metal up to 3/16" or 4.8 mm thick.

Also use the single - piece Shield Cup for 'standoff' cutting (with the torch tip 1/8" to 1/4" from the workpiece). This is the preferred method for cutting metal thicker than 3/16" / 4.8 mm and at current levels above 40 amps. This provides maximum visibility and accessibility.

Use the Shield Cup Body with the Deflector Shield Cap for extended parts life and improved resistance to reflected heat. This combination provides cutting results similar to the single-piece Shield Cup, as well as easy change-over to gouging or drag shield cutting.

Use the Shield Cup Body with the Drag Shield Cap for a consistent standoff distance with the drag shield in contact with the workpiece. This is a simple and operator-friendly method of cutting between 50 and 100 amps.

Use the Shield Cup Body with the Gouging Shield Cap for excellent gouging performance and enhanced torch parts life.

The electrode and starter cartridge are the same for all operations.

Consumables Selection (All Applications)

Use only Genuine Thermal Dynamics consumables with this torch. The use of any other consumables may irreparably damage the torch.

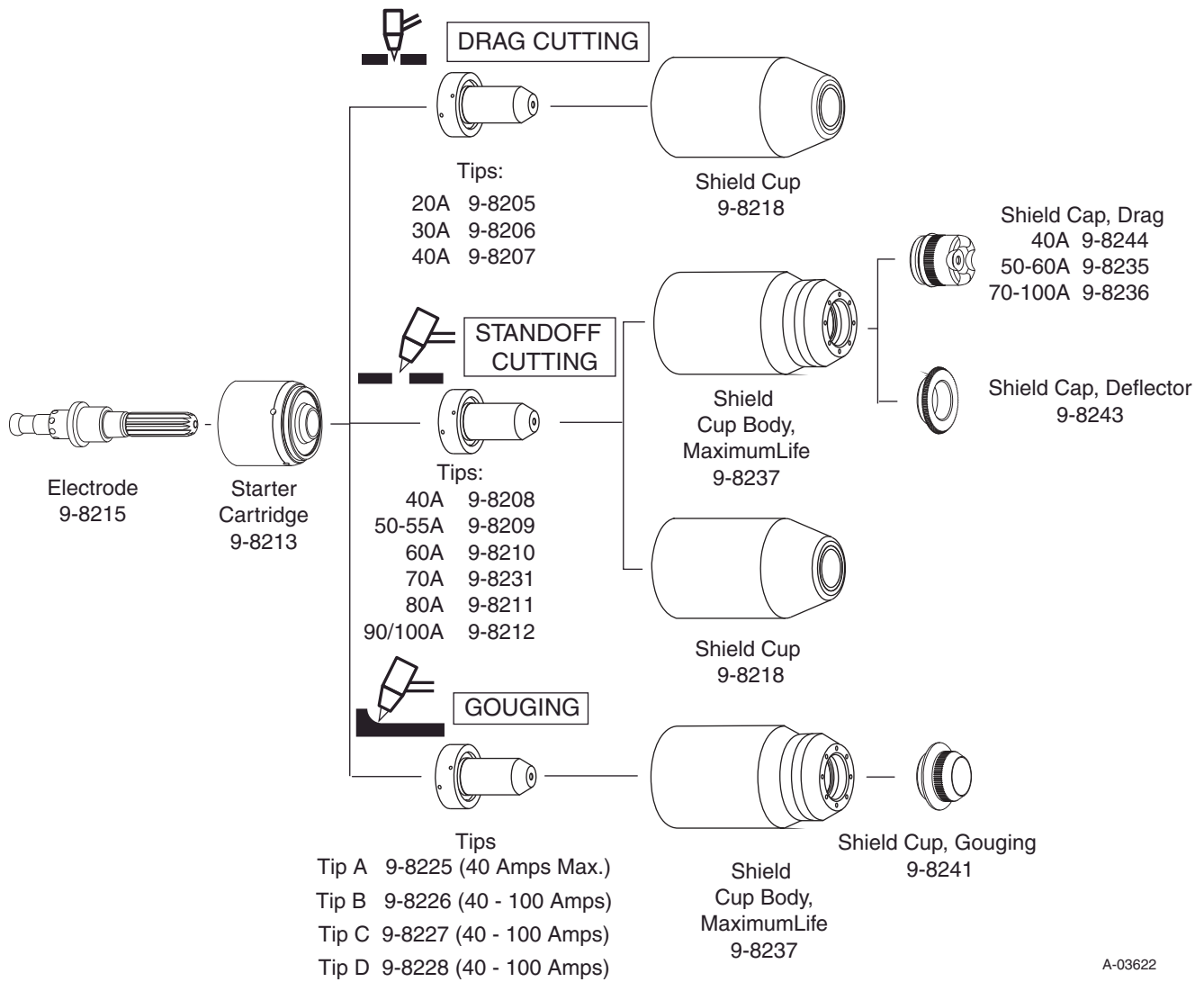

Gouging Profiles			
	Output Range	Depth	Width
Tip A	40 Amps Max.	Shallow	Narrow
Tip B	40-100 Amps	Deep	Narrow
Tip C	40-100 Amps	Moderate	Moderate
Tip D	40-100 Amps	Shallow	Wide

Replacement Hand Torch Parts

Item #	Qty	Description	Catalog #
1	1	Torch Handle Replacement Kit (includes items No. 2 & 3)	9-7030
2	1	Trigger Assembly Replacement Kit	9-7034
3	1	Handle Screw Kit (5 each, 6-32 x 1/2" cap screw, and wrench)	9-8062
4	1	Torch Head Assembly Replacement Kit (includes items No. 5 & 6)	9-8219
5	1	Large O - Ring	8-3487
6	1	Small O - Ring	8-3486
7		Leads Assemblies with O2B connectors (includes switch assemblies)	
	1	SL60 / 60 Amp, 20 - foot Leads Assembly with O2B connectors	4-7830
	1	SL60 / 60 Amp, 50 - foot Leads Assembly with O2B connectors	4-7831
	1	SL100 / 100 Amp, 20 - foot Leads Assembly with O2B connectors	4-7832
	1	SL100 / 100 Amp, 50 - foot Leads Assembly with O2B connectors	4-7833
8		Leads Assemblies with ATC connectors (includes switch assemblies)	
	1	SL60 / 60 Amp, 20 - foot Leads Assembly with ATC connector	4-7834
	1	SL60 / 60 Amp, 50 - foot Leads Assembly with ATC connector	4-7835
	1	SL100 / 100 Amp, 20 - foot Leads Assembly with ATC connector	4-7836
	1	SL100 / 100 Amp, 50 - foot Leads Assembly with ATC connector	4-7837
9	1	Switch Kit	9-7031

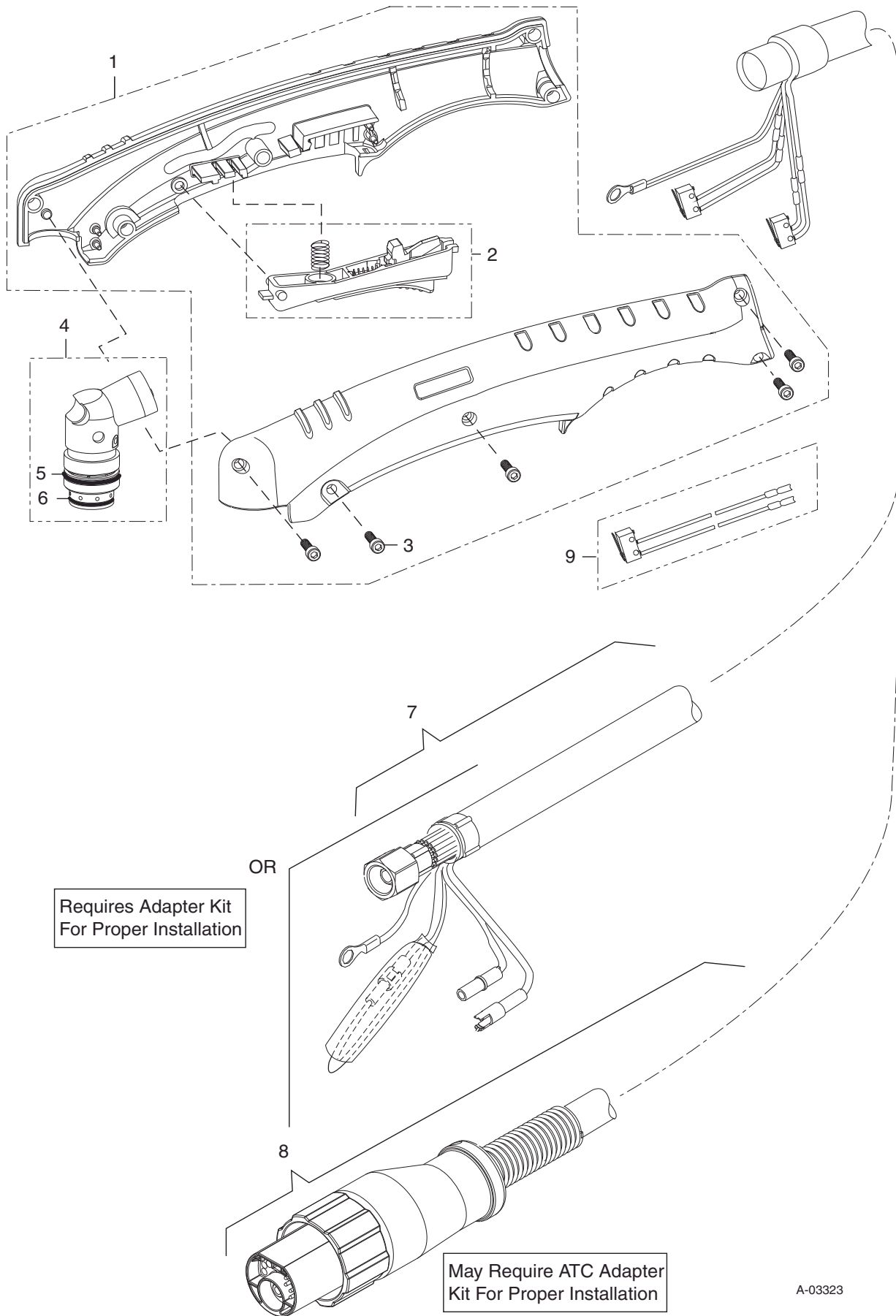

Requires Adapter Kit
For Proper Installation

OR

May Require ATC Adapter
Kit For Proper Installation

A-03323

Complete Assembly Replacement

NOTE

All Complete Torch and Lead Assemblies require a Torch Adapter Kit for proper installation of the Torch.

Description	Catalog No.
60 - Amp Hand Torches with Ergonomic Handle:	
SL60 Hand Torch and 20 foot / 6.1 m Leads, with O2B Connector	7-5200
SL60 Hand Torch and 50 foot / 15.2 m Leads, with O2B Connector	7-5201
SL60 Hand Torch and 20 foot / 6.1 m Leads, with ATC Connector	7-5204
SL60 Hand Torch and 50 foot / 15.2 m Leads, with ATC Connector	7-5205
100 - Amp Hand Torches with Ergonomic Handle:	
SL100 Hand Torch and 20 foot / 6.1 m Leads, with O2B Connector	7-5202
SL100 Hand Torch and 50 foot / 15.2 m Leads, with O2B Connector	7-5203
SL100 Hand Torch and 20 foot / 6.1 m Leads, with ATC Connector	7-5206
SL100 Hand Torch and 50 foot / 15.2 m Leads, with ATC Connector	7-5208
Options:	
ATC Adapter Kit	7-5207
Leads extensions with ATC connectors, 15 - foot / 4.6 m length	7-7544
Leads extensions with ATC connectors, 25 - foot / 7.6 m length	7-7545
Leads extensions with ATC connectors, 50 - foot / 15.2 m length	7-7552
Leather Leads Cover, 20 foot / 6.1 m length	9-1260
Leather Leads Cover, 25 foot / 7.6 m length	9-1270
Leather Leads Cover, 50 foot / 15.2 m length	9-1280
Straight Line Cutting Guide	7-8911
Radius / Roller Kit	7-7501
Circle Cutting Guide	7-3291
Deluxe Cutting Guide Kit	7-8910

NOTE

Every effort has been made to provide complete and accurate information in this manual. However, the publisher does not assume and hereby disclaims any liability to any party for any loss or damage caused by errors or omissions in this Manual, whether such errors result from negligence, accident, or any other cause.

Statement of Warranty

LIMITED WARRANTY: Thermal Dynamics® Corporation (hereinafter “Thermal”) warrants that its products will be free of defects in workmanship or material. Should any failure to conform to this warranty appear within the time period applicable to the Thermal products as stated below, Thermal shall, upon notification thereof and substantiation that the product has been stored, installed, operated, and maintained in accordance with Thermal’s specifications, instructions, recommendations and recognized standard industry practice, and not subject to misuse, repair, neglect, alteration, or accident, correct such defects by suitable repair or replacement, at Thermal’s sole option, of any components or parts of the product determined by Thermal to be defective.

This warranty is exclusive and is in lieu of any warranty of merchantability or fitness for a particular purpose.

LIMITATION OF LIABILITY: Thermal shall not under any circumstances be liable for special or consequential damages, such as, but not limited to, damage or loss of purchased or replacement goods, or claims of customers of distributor (hereinafter “Purchaser”) for service interruption. The remedies of the Purchaser set forth herein are exclusive and the liability of Thermal with respect to any contract, or anything done in connection therewith such as the performance or breach thereof, or from the manufacture, sale, delivery, resale, or use of any goods covered by or furnished by Thermal whether arising out of contract, negligence, strict tort, or under any warranty, or otherwise, shall not, except as expressly provided herein, exceed the price of the goods upon which such liability is based.

This warranty becomes invalid if replacement parts or accessories are used which may impair the safety or performance of any Thermal Product.

This warranty becomes invalid if the product is sold by non - authorized persons.

All SureLok™ RPT Torches have a one year Parts & Labor warranty

Warranty repairs or replacement claims under this limited warranty must be submitted by an authorized Thermal Dynamics® repair facility within thirty (30) days of the repair. No transportation costs of any kind will be paid under this warranty. Transportation charges to send products to an authorized warranty repair facility shall be the responsibility of the customer. All returned goods shall be at the customer’s risk and expense.



Thermal Dynamics Corporation
82 Benning Street
West Lebanon, NH 03784 USA
1-800-PLASMA-1
Telephone: 603-298-5711
www.thermal-dynamics.com

1Torch™

with SURELOK® Technology

Torch and Lead Selection

Listed below are the Torch and Lead selection charts for the SL100™ Machine 1Torch RPT torch.

1

ORDERING INFORMATION

Machine Torch

SL100™

Medium/Heavy Duty Torch
30-100 Amps





Standard

Shielded¹

CAT NO. DESCRIPTION

CAT NO. DESCRIPTION

A	Standard RPT (O₂B) Torch Connection		
	Torch & Leads		
	SL100 Machine Torch (Fiberglass Tube w/ Rack) 7-5209 SL100, 180°, 25' (7.6m) Torch/Leads 7-5210 SL100, 180°, 50' (15.2m) Torch/Leads Remote Interface Adapter 7-3452 included with torch.		

A	Standard RPT (O₂B) Torch Connection		
	Torch & Leads		
	SL100 Machine Torch - Shielded (Fiberglass Tube w/ Rack) 7-5211 SL100, 180°, 25' (7.6m) Torch/Leads 7-5212 SL100, 180°, 50' (15.2m) Torch/Leads Remote Interface Adapter 7-3452 included with torch.		

B	ATC™ Torch Connection		
	Torch & Leads		
	SL100 Machine Torch w/ ATC (Fiberglass Tube w/ Rack) 7-5213 SL100, 180°, 5' (1.5m) Torch/Leads 7-5214 SL100, 180°, 10' (3.0m) Torch/Leads 7-5215 SL100, 180°, 25' (7.6m) Torch/Leads 7-5216 SL100, 180°, 50' (15.2m) Torch/Leads		

B	ATC™ Torch Connection		
	Torch & Leads		
	SL100 Machine Torch w/ ATC - Shielded (Fiberglass Tube w/ Rack) 7-5219 SL100 ¹ , 180°, 5' (1.5m) Torch/Leads 7-5220 SL100 ¹ , 180°, 10' (3.0m) Torch/Leads 7-5221 SL100 ¹ , 180°, 25' (7.6m) Torch/Leads 7-5222 SL100 ¹ , 180°, 50' (15.2m) Torch/Leads		

ATC™ Adapter Kit	
ATC Adapter	
7-5207	ATC Receptacle Connector 

* This receptacle adapter is required for each power supply using an ATC torch connection. This is connected to the torch adapter kit specific to each power supply.

ATC™ Adapter Kit	
ATC Adapter - Shielded	
7-3472	ATC Receptacle Connector 

* This receptacle adapter is required for each power supply using an ATC torch connection. This is connected to the torch adapter kit specific to each power supply.

ATC™ Lead Extensions²	
Lead Extensions - Standard	
7-7544	15' (4.5m) Lead Extension
7-7545	25' (7.6m) Lead Extension
7-7552	50' (15.2m) Lead Extension

ATC™ Lead Extensions²	
Lead Extensions - Standard	
7-7854	25' (7.6m) Lead Extension
7-7855	50' (15.2m) Lead Extension

Mechanized Remote Controls	
Remote Interface Connectors	
7-3474	ATC Remote Interface Adapter Provides an optional remote interface connection to allow the use of any remote control. Can be placed anywhere between the ATC Torch connection or Lead Extension and ATC Adapter.
7-3452	Remote Pendant Interface Kit Interfaces into any torch adapter kit to allow the use of a Remote Pendant (7-3460) on any Mechanized torch system.
7-3460	Remote Pendant Control
9-5651	25 ft. CNC Remote Cable
9-5652	50 ft. CNC Remote Cable

Mechanized Remote Options	
Remote Interface Connectors	
7-3452	Remote Pendant Interface Kit Interfaces into any torch adapter kit to allow the use of a Remote Pendant (7-3460) on any Mechanized torch system.
7-3460	Remote Pendant Control
9-5651	25 ft. CNC Remote Cable
9-5652	50 ft. CNC Remote Cable

NOTES: (1) It is only recommended to install shielded torches onto a shielded ready system. Installation onto a non-shielded system may result in reduced performance. Installing a shielded torch on to a shielded system requires the shield connections to be terminated to a proper shield termination or earth ground point.
 (2) Lead extensions are available for torches with ATC connections. It is suggested that the total lead length including torch and extension(s) not exceed the maximum lead length specified by the power supply manufacturer.

**Model SL100 RPT
Replacement Plasma Cutting
Machine Torches**

Installation and Operation Instructions

General Information

The SL100 SureLok[®] Torch works with most plasma cutting power supplies. The Torch is equipped with either O2B connectors or the Thermal Dynamics ATC connector. Installation requires an Adapter Kit sold separately.

The Torch provides cutting capabilities of up to 100 amperes. The torch uses compressed air as both the plasma and secondary gas. Single - gas operation provides a smaller torch and inexpensive operation.

Refer to the Complete Assembly Replacement page for configurations and catalog numbers.

These instructions are important for the proper installation of the Torch. Read the instructions thoroughly before attempting the installation. Keep these instructions for reference.

Supplied Parts

The Replacement Torch kits include:

- Torch With Leads - 1 each
- Installation Instructions - 1 each
- Consumables (SureLok MaximumLife[™] Electrode, Starter Cartridge, Tip, and Shield Cup)

NOTE

The consumable parts installed in the Torch may not necessarily be optimized for your Power Supply or cutting application. For best results, refer to the selection chart in this manual to choose the proper consumables.

Options

The following options are available. Refer to the parts lists for catalog numbers.

- ATC Adapter Kit (for Torches with ATC connections)
- Leads extensions (for Torches with ATC connections)
- Leather Leads Covers
- Ohmic Clip Kit
- Pinion
- 5" / 127 mm Positioning Tube

Torch Specifications

A. Torch Configuration and Dimensions

The Torch is available with mounting tube with rack and pinch block assembly.

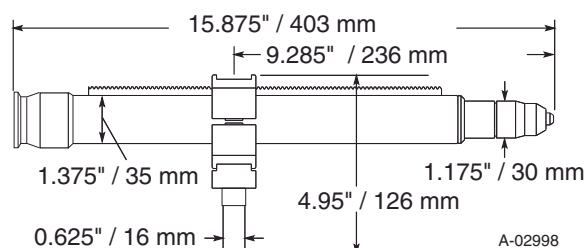

A-02998

B. Torch Leads Lengths

The torch is available with leads as follows:

Leads Type	Lengths Available
Unshielded Leads, O2B Connectors	25 foot / 7.6 m, 50 foot / 15.2 m
Shielded Leads, O2B Connectors	25 foot / 7.6m, 50 foot / 15.2 m
Unshielded Leads, ATC Connectors	5 foot / 1.5 m, 10 foot / 3.05 m, 25 foot / 7.6 m, 50 foot / 15.2 m
Shielded Leads, ATC Connectors	5 foot / 1.5 m, 10 foot / 3.05 m, 25 foot / 7.6 m, 50 foot / 15.2 m
Unshielded Extensions, ATC Connectors	15 foot / 4.6 m, 25 foot / 7.6 m, 50 foot / 15.2 m
Shielded Extensions, ATC Connectors	25 foot / 7.6 m, 50 foot / 15.2 m

For torch leads with ATC Connectors, leads extensions are available to extend the leads to a maximum of 50 feet / 15.2 m. Total leads lengths must not exceed the power supply manufacturer's recommendations.

C. Current Rating (Refer to Note)

- Up to 100 Amps, DC, straight polarity

NOTE

Power Supply characteristics will determine material thickness range.

D. Torch Ratings

SL100 Torch Ratings	
Ambient Temperature	104° F 40° C
Duty Cycle	100% @ 100 Amps @ 400 scfh
Maximum Current	100 Amps
Voltage (V _{peak})	500V
Arc Striking Voltage	7kV

E. Type of Cooling

Combination of ambient air and gas stream through torch.

F. Parts - In - Place (PIP) Circuit - 12 vdc

The torch and leads include circuitry called Parts - In - Place (PIP). This circuit includes a switch located at the torch head. The shield cup closes this switch when properly installed. The torch will not operate if this switch is open.

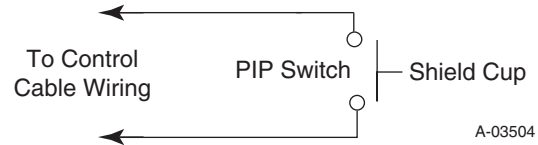

G. Direct Contact Hazard

For exposed tip the recommended standoff is 3/16" / 4.7 mm.

H. Gas Requirements

SL100 Torch Gas Specifications	
Gas (Plasma and Secondary)	Compressed Air
Operating Pressure <i>Refer to NOTE</i>	55 - 70 psi 3.8 - 5.2 bar
Maximum Input Pressure	125 psi / 8.6 bar
Gas Flow	300 - 500 scfh 142 - 235 lph



WARNING

This torch is not to be used with oxygen (O₂).

NOTE

Operating pressure varies with torch model, operating amperage, and torch leads length. Refer to gas pressure settings charts.

Connecting Torch

There are two types of connection for the Torch Leads. One type uses the Thermal Dynamics ATC connector. The other uses standard (O2B) connections for gas and circuitry. Both types may require an adapter kit sold separately.

Connections with Adapter Kits

Leads with ATC Connectors

Connect the torch leads to the power supply per the instructions provided with the appropriate adapter kit.



WARNING

The shield connectors on the Adapter Leads should be connected to the power supply in accordance with instructions provided by the power supply manufacturer. Use of a shielded torch on power supplies not specifically designed for shielded leads may result in damage to the power supply or improper function.

Inspect the halves of the ATC Connector. Align the male connector with the female receptacle and push them together by hand until they seat fully. Turn the Locking Ring until it pulls the halves of the connector together fully. Do not use tools to tighten the connector. If there is any resistance to the ring turning, pull the halves of the connector apart, realign the inner components, ensure that the threaded components are aligned, and push the halves of the connector together again.

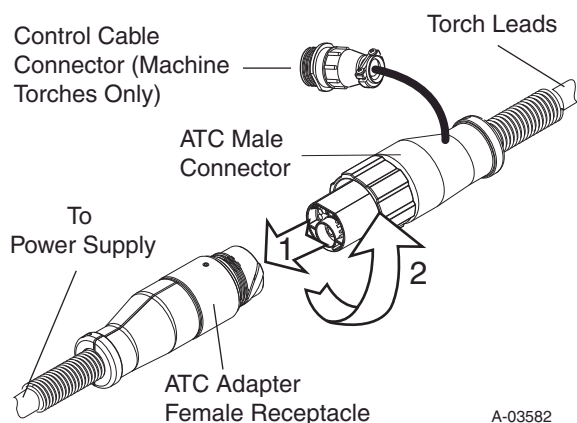

Leads with Standard (O2B) Connectors

Connect the torch leads to the power supply per the instructions provided with the appropriate adapter kit.

Spare Parts Label

The parts kit provided with this torch includes an adhesive label. Select the small perforated section showing the appropriate pressure setting for the amperage output and leads length to be used with this torch. Refer to the charts. Apply this section in the 'Gas Supply' area of the label under the 'Recommended operating pressure' text. Discard any pressure setting sections of the label that will not be used. Apply the large label to the power supply, where the operator can see it for easy reference.

Torch Parts Selection

Refer to the **Consumables Selection Chart** for the various torch parts for the application and operation.



WARNINGS

Disconnect primary power to the system before disassembling the torch or torch leads.

DO NOT touch any internal torch parts while the AC indicator light of the Power Supply is ON.

The shield cup (or shield cup body and end cap or deflector) holds the tip and starter cartridge in place. Put one hand under the shield cup to catch the tip and starter cartridge when the cup is removed.

Change the torch parts as follows:

1. Unscrew and remove the shield cup from the torch head.

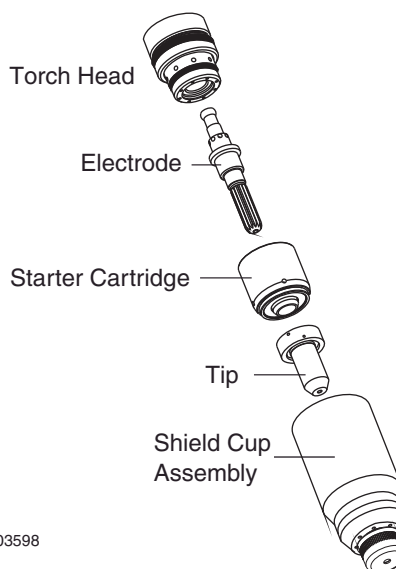

2. Fit the starter cartridge and desired tip onto the electrode.

NOTE

Refer to the consumables selection chart for the proper combination of torch parts, including shield retainers and cups.

3. Fit the shield cup onto the torch head.
4. Hand tighten the shield cup until it is seated on the torch head. **Do not use tools to tighten the cup.** If resistance is felt when installing the cup, check the threads before proceeding.

NOTE

When operating the torch in a normal condition, a small amount of gas vents through the gap between the shield cup and torch handle. Do not attempt to over tighten the shield cup as irreparable damage to internal components may result.

Operating Gas Pressure

Set gas pressure at the power supply regulator according to the following chart. This chart is a guide only; adjust as necessary for best performance.

SL100 Gas Pressure Settings		
	Total Leads Length	
Tip	Up to 25' / 7.6 m	50' / 15.2 m
30A	55 psi / 3.8 bar	60 psi / 4.1 bar
40A	55 psi / 3.8 bar	60 psi / 4.1 bar
50/55A	60 psi / 4.1 bar	65 psi / 4.5 bar
60A	60 psi / 4.1 bar	65 psi / 4.5 bar
70A	60 psi / 4.1 bar	65 psi / 4.5 bar
80A	60 psi / 4.1 bar	65 psi / 4.5 bar
90 / 100 A	65 psi / 4.5 bar	70 psi / 5.2 bar

Sequence of Operation

1. Turn on power and adjust gas pressure on the Power Supply pressure gauge. Refer to the chart for optimum pressure settings for the combination of torch consumables and total leads lengths (including extensions) in use.

2. Adjust current output on the Power Supply to match the selected tip and attach the work clamp firmly to the work or to the cutting table.



WARNING

Maximum current for this torch is 100 Amps. Operation of this torch at higher outputs may damage the torch, the leads, the components, or the Power Supply. DO NOT operate the torch at more than 100 Amps.

NOTE

The gas preflow and postflow are characteristics of the power supply and not a function of the torch.

3. Recommended standoff distance is 3/16" / 4.7 mm.
4. Follow normal recommended cutting practices as provided in the power supply operator's manual.

NOTE

When the shield cup is properly installed, there is a slight gap between the shield cup and the torch handle. Gas vents through this gap as part of normal operation. Do not attempt to force the shield cup to close this gap. Forcing the shield cup against the torch head or torch handle can damage components.

Cutting With Machine Torch

The machine torch can be activated by remote control pendant or by a remote interface device such as CNC.

Common Operating Faults

The following are the more common cutting faults and the possible causes:

1. Insufficient Penetration

- a. Cutting speed too fast
- b. Torch tilted too much
- c. Metal too thick
- d. Worn torch parts
- e. Cutting current too low
- f. Non - Genuine Thermal Dynamics Parts

2. Main Arc Extinguishes

- a. Cutting speed too slow
- b. Torch standoff too high from workpiece
- c. Cutting current too high
- d. Work cable disconnected
- e. Worn torch parts
- f. Non - Genuine Thermal Dynamics Parts

3. Excessive Dross Formation

- a. Cutting speed too slow
- b. Torch standoff too high from workpiece
- c. Worn torch parts
- d. Improper cutting current
- e. Non - Genuine Thermal Dynamics Parts

4. Short Torch Parts Life

- a. Oil or moisture in air source
- b. Exceeding system capability (material too thick)
- c. Excessive pilot arc time
- d. Gas pressure too low
- e. Improperly assembled torch
- f. Non - Genuine Thermal Dynamics Parts

5. Difficult Starting

- a. Worn torch consumables
- b. Non - Genuine Thermal Dynamics Parts

Inspection and Replacement of Consumable Torch Parts



WARNINGS

Disconnect primary power to the system before disassembling the torch or torch leads.

DO NOT touch any internal torch parts while the AC indicator light of the Power Supply is ON.

Remove the consumable torch parts.

1. Inspect the cup for damage. Wipe it clean or replace if damaged. Slag built up on the shield cup that cannot be removed may affect the performance of the system.

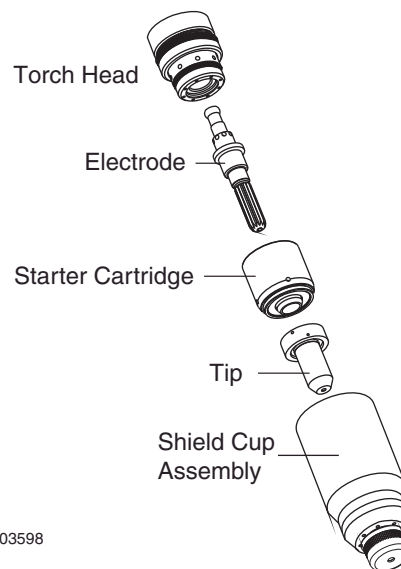

2. Check the tip for excessive wear (indicated by an elongated or oversized orifice). Clean or replace the tip if necessary.

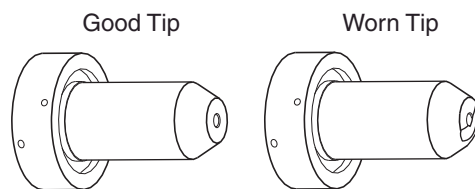

3. Check the starter cartridge for excessive wear, plugged gas holes, discoloration, and for free movement of the lower end plate. Replace if necessary.

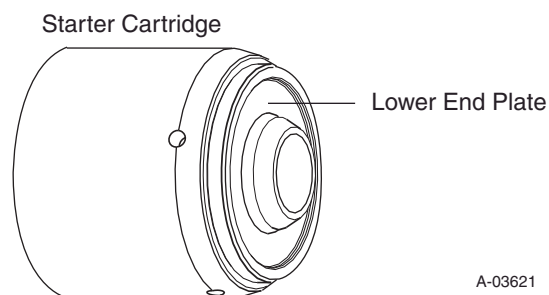

4. Check the face of the electrode for excessive wear.

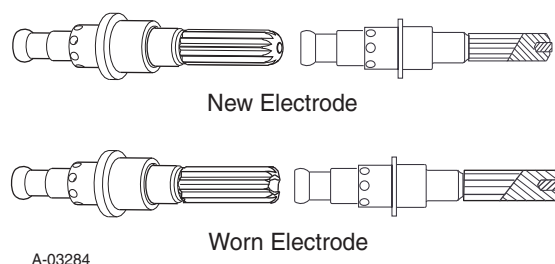

5. Reinstall the Electrode by pushing it straight into the torch head until it clicks.



WARNINGS

Refer to the consumables selection charts for the proper combination of torch parts, including shield retainers and shield cups.

The use of any consumable parts other than those specified by the Manufacturer may cause irreparable damage to the torch head.

6. Hold the starter cartridge and tip in place on the electrode.
7. Hand tighten the shield cup until it is seated on the torch head. If resistance is felt when installing the cup, check the threads before proceeding.

CAUTION

When operating the torch in a normal condition, a small amount of gas vents through the gap between the shield cup and torch handle. Do not attempt to over tighten the shield cup as irreparable damage to internal components may result.

Consumables Selection

Various front - end torch parts are available for different applications.

Use the single - piece Shield Cup for 'standoff' cutting (with the torch tip 1/8" to 1/4" from the workpiece). This is the preferred method for cutting metal thicker than 3/16" / 4.8 mm and at current levels above 40 amps. This provides maximum visibility and accessibility.

Use the Shield Cup Body with the Deflector Shield Cap for extended parts life and improved resistance to reflected heat. This combination provides cutting results similar to the single-piece Shield Cup, as well as easy change-over to gouging or drag shield cutting.

Use the Shield Cup Body with the Gouging Shield Cap for excellent gouging performance and enhanced torch parts life.

The electrode and starter cartridge are the same for all operations.

Consumables Selection

Use only Genuine Thermal Dynamics consumables with this torch. The use of any other consumables may irreparably damage the torch.

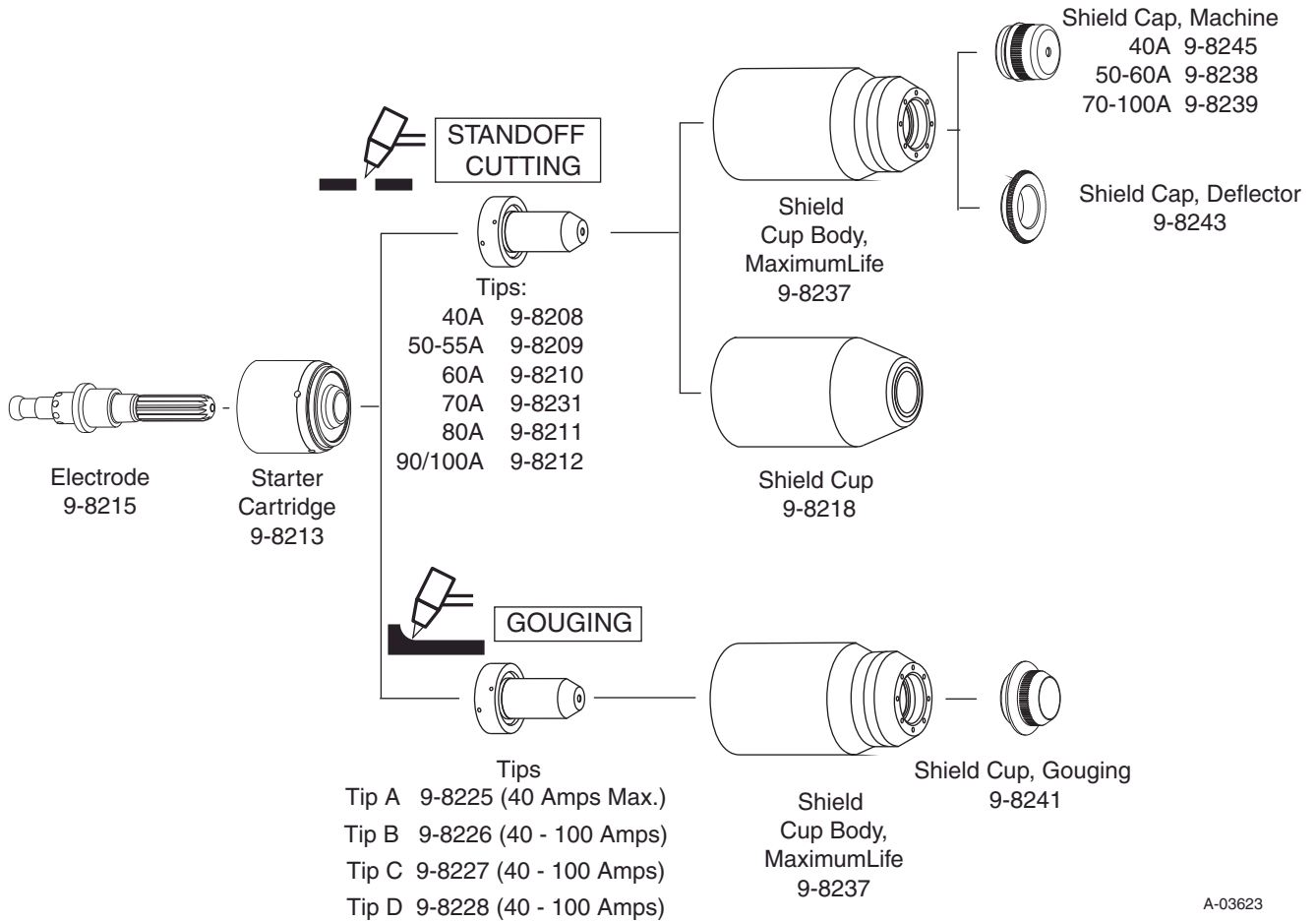

A-03623

Gouging Profiles			
	Output Range	Depth	Width
Tip A	40 Amps Max.	Shallow	Narrow
Tip B	40-100 Amps	Deep	Narrow
Tip C	40-100 Amps	Moderate	Moderate
Tip D	40-100 Amps	Shallow	Wide

Replacement Parts - for Machine Torches with Unshielded Leads

Item No.	Qty	Description	Catalog No.
1	1	Torch Head Assembly without leads (includes items 2, 3, and 14)	9-8220
2	1	Large O - Ring	8-3487
3	1	Small O - Ring	8-3486
4	1	PIP Switch Kit	9-7036
5		Unshielded Mechanized Leads Assemblies with O2B connectors	
	1	25 - foot / 7.6 m Leads Assembly with O2B connectors	4-7838
	1	50 - foot / 15.2 m Leads Assembly with O2B connectors	4-7839
7		Unshielded Mechanized Leads Assemblies with ATC connectors	
	1	5 - foot / 1.5 m Leads Assembly with ATC connector	4-7842
	1	10 - foot / 3.05 m Leads Assembly with ATC connector	4-7843
	1	25 - foot / 7.6 m Leads Assembly with ATC connector	4-7844
	1	50 - foot / 15.2 m Leads Assembly with ATC connector	4-7845
8	1	11" / 279 mm Rack	9-7041
9	1	11" / 279 mm Mounting Tube	9-7043
10	1	End Cap Assembly	9-7044
11	2	Body, Mounting, Pinch Block	9-4513
12	1	Pin, Mounting, Pinch Block	9-4521
13	1	Torch Holder Sleeve	7-2896
14	1	PIP Plunger and Return Spring Kit	9-7045

NOTE

Refer to Page 10 for Replacement Shielded Leads Assemblies.

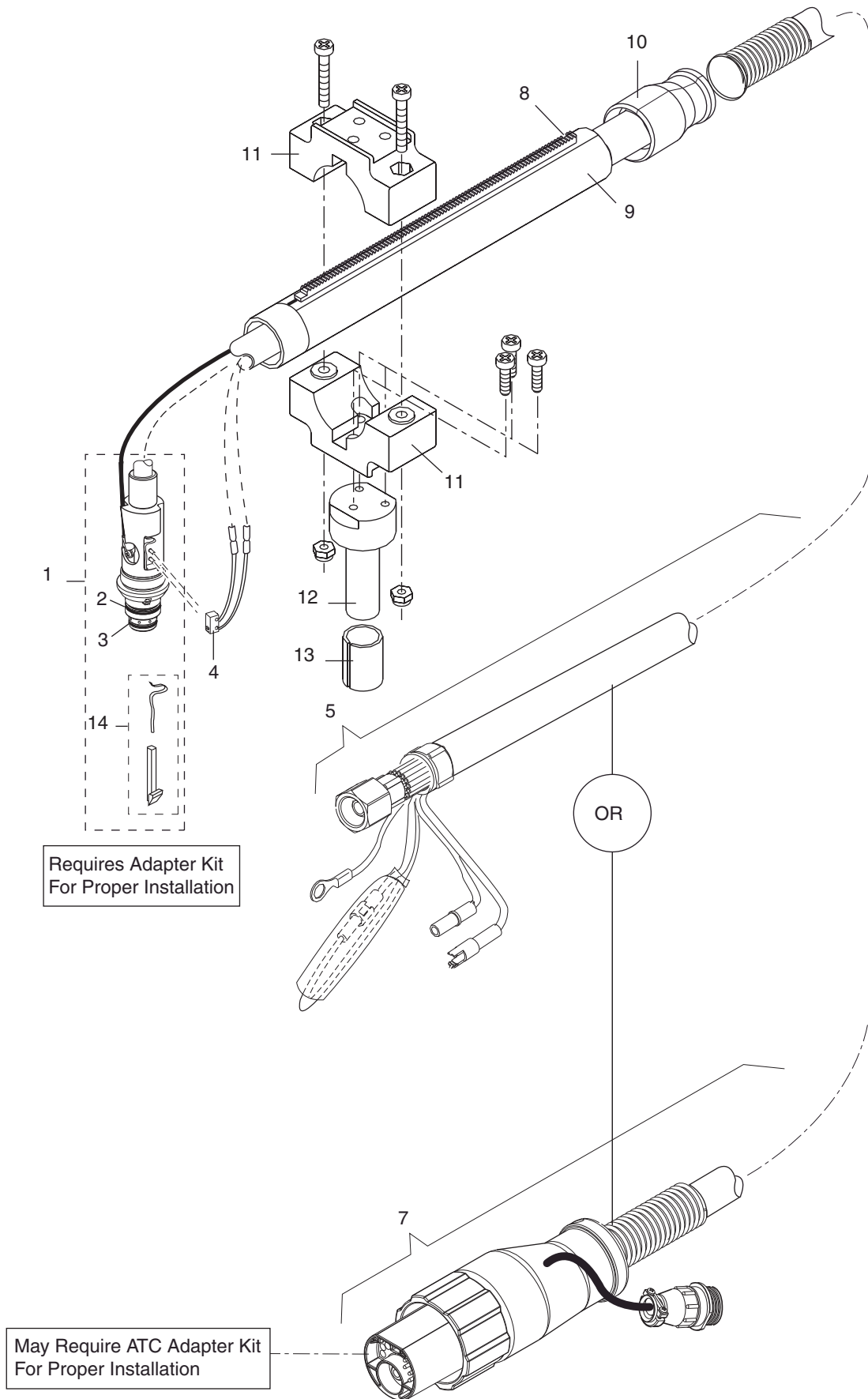

A-03404

Replacement Shielded Machine Torch Leads Assemblies and Components

Item No.	Qty	Description	Catalog No.
1		Mechanized Shielded Leads Assemblies with ATC Connectors	
	1	5 - foot / 1.5 m Leads Assembly with ATC Connector	4-7846
	1	10 - foot / 3.05 m Leads Assembly with ATC Connector	4-7847
	1	25 - foot / 7.6 m Leads Assembly with ATC Connector	4-7848
	1	50 - foot / 15.2 m Leads Assembly with ATC Connector	4-7849
2		Shielded Leads Assemblies with O2B Connectors	
	1	25 - foot / 7.6 m Leads Assembly with O2B Connector	4-7840
	1	50 - foot / 15.2 m Leads Assembly with O2B Connector	4-7841
3		PIP Lead Assembly for Shielded Leads with ATC Connectors	
	1	5 - foot / 1.5 m Length	9-7961
	1	10 - foot / 3.05 m Length	9-7962
	1	25 - foot / 7.6 m Length	9-7963
	1	50 - foot / 15.2 m Length	9-7964
4		Lead Shield for Shielded Leads with ATC Connectors	
	1	5 - foot / 1.5 m Length	9-7965
	1	10 - foot / 3.05 m Length	9-7966
	1	25 - foot / 7.6 m Length	9-7967
	1	50 - foot / 15.2 m Length	9-7968
5		Negative Lead for Shielded Leads with ATC Connectors	
	1	5 - foot / 1.5 m Length	9-7947
	1	10 - foot / 3.05 m Length	9-7948
	1	25 - foot / 7.6 m Length	9-7949
	1	50 - foot / 15.2 m Length	9-7955
6		Pilot Lead for Shielded Leads with ATC Connectors	
	1	5 - foot / 1.5 m Length	9-7956
	1	10 - foot / 3.05 m Length	9-7963
	1	25 - foot / 7.6 m Length	9-7958
	1	50 - foot / 15.2 m Length	9-7959
7		Negative Lead Assembly for Shielded Leads with O2B Connectors	
	1	25 - foot / 7.6 m Length	9-7969
	1	50 - foot / 15.2 m Length	9-7974
8		Lead Shield for Shielded Leads with O2B Connectors	
	1	25 - foot / 7.6 m Length	9-7979
	1	50 - foot / 15.2 m Length	9-7980
9		PIP Lead for Shielded Leads with O2B Connectors	
	1	25 - foot / 7.6 m Length	9-7977
	1	50 - foot / 15.2 m Length	9-7978
10		Pilot Lead for Shielded Leads with O2B Connectors	
	1	25 - foot / 7.6 m Length	9-7975
	1	50 - foot / 15.2 m Length	9-7976

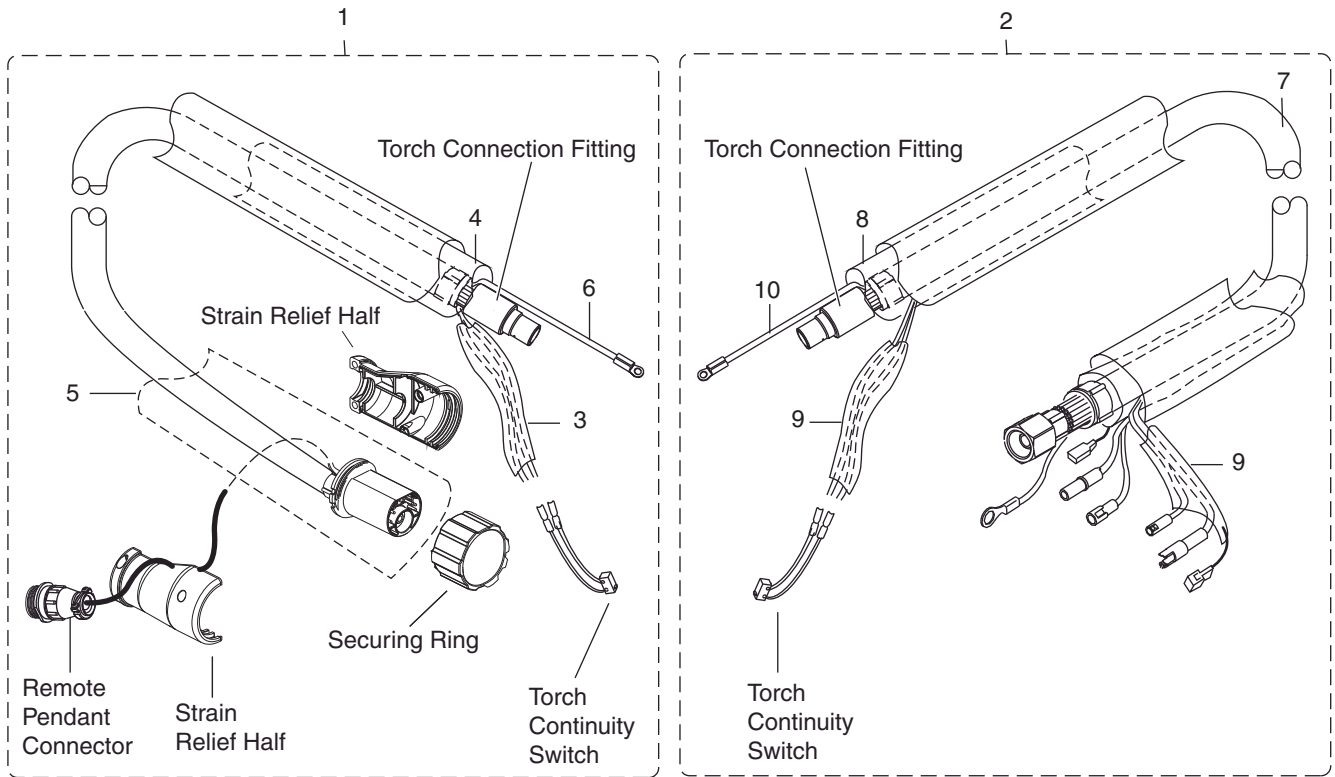

A-03616

NOTES

- Item 3 does not include torch continuity switch.
- Item 5 includes Torch Connection Fitting.
- Item 5 does not include Strain Relief Halves, Remote Pendant Connector, or Securing Ring.

NOTES

- Item 7 includes Torch Connection Fitting.
- Item 9 does not include torch continuity switch.

Complete Torch and Leads Assembly Replacement

NOTE

All Complete Torch and Lead Assemblies require a Torch Adapter Kit for proper installation of the Torch.

Description	Catalog No.
100 - Amp Mechanized Torches, Unshielded Leads, O2B Connectors	
SL100 Machine Torch, 25 foot / 7.6 m Leads, with O2B Connector	7-5209
SL100 Machine Torch, 50 foot / 15.2 m Leads, with O2B Connector	7-5210
100 - Amp Mechanized Torches, Unshielded Leads, ATC Connectors	
SL100 Machine Torch, 5 foot / 1.5 m Leads, with ATC Connector	7-5213
SL100 Machine Torch, 10 foot / 3 m Leads, with ATC Connector	7-5214
SL100 Machine Torch, 25 foot / 7.6 m Leads, with ATC Connector	7-5215
SL100 Machine Torch, 50 foot / 15.2 m Leads, with ATC Connector	7-5216
100 - Amp Mechanized Torches, Shielded Leads, O2B Connectors	
SL100 Machine Torch, 25 foot / 7.6 m Shielded Leads, with O2B Connector	7-5211
SL100 Machine Torch, 50 foot / 15.2 m Shielded Leads, with O2B Connector	7-5212
100 - Amp Mechanized Torches, Shielded Leads, ATC Connectors	
SL100 Machine Torch, 5 foot / 1.5 m Shielded Leads, with ATC Connector	7-5219
SL100 Machine Torch, 10 foot / 3 m Shielded Leads, with ATC Connector	7-5220
SL100 Machine Torch, 25 foot / 7.6 m Shielded Leads, with ATC Connector	7-5221
SL100 Machine Torch, 50 foot / 15.2 m Shielded Leads, with ATC Connector	7-5222
Options:	
Unshielded ATC Adapter Kit	7-5207
Shielded ATC Adapter Kit	7-3472
Ohmic Clip Kit	9-8224
Leads extensions with ATC connectors, 15 - foot / 4.6 m length	7-7544
Leads extensions with ATC connectors, 25 - foot / 7.6 m length	7-7545
Leads extensions with ATC connectors, 50 - foot / 15.2 m length	7-7552
Shielded Leads extensions with ATC connectors, 25 - foot / 7.6 m length	4-7854
Shielded Leads extensions with ATC connectors, 50 - foot / 15.2 m length	4-7855
Leather Leads Cover, 25 foot / 7.6 m	9-1270
Leather Leads Cover, 50 foot / 15.2 m	9-1280

Standard Torch Control Cable for Start / Stop Only Mechanized Systems

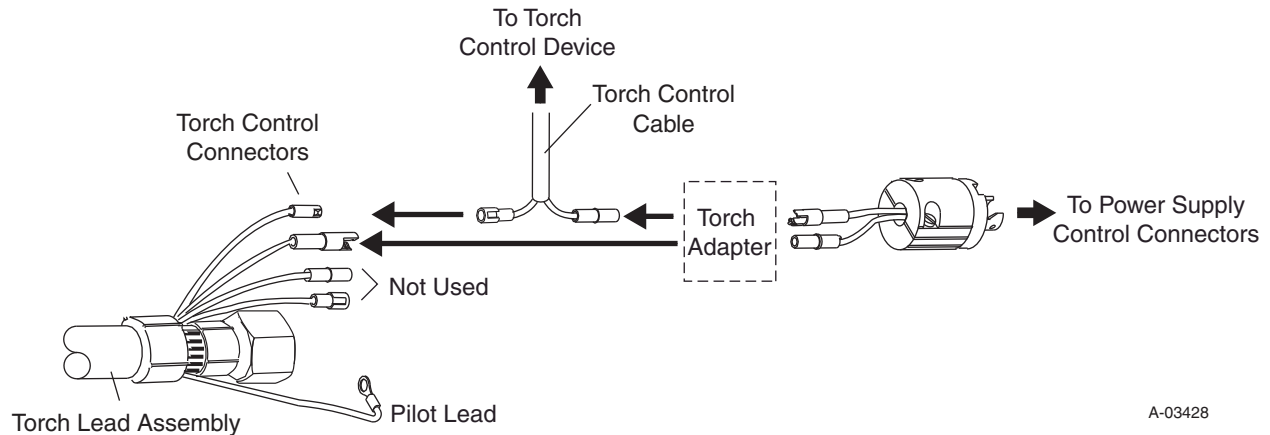

Optional Torch Control Cable For CNC / Remote Pendant Systems

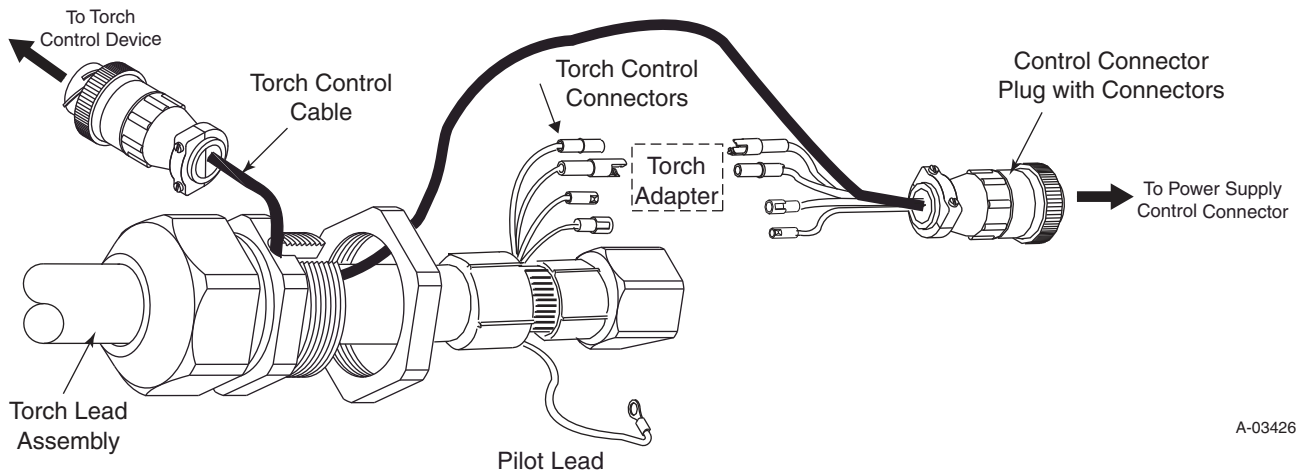

NOTE

Leads are available only for Thermal Dynamics Product and are not to be installed on any other products.



WARNING - Replacing Original Machine Torch with TDC RPT Mechanized Torch

Thermal Dynamics RPT Mechanized torches have two control wires that are used for Parts - In - Place only. Do not connect these connections directly into any start input, because when the torch parts are in place, the start signal will always be energized. If the torch parts are not in place but are subsequently installed with the start signal energized, the shield cup will complete the start circuit and the unit will immediately start a pilot arc.

NOTE

Every effort has been made to provide complete and accurate information in this manual. However, the publisher does not assume and hereby disclaims any liability to any party for any loss or damage caused by errors or omissions in this Manual, whether such errors result from negligence, accident, or any other cause.

Statement of Warranty

LIMITED WARRANTY: Thermal Dynamics[®] Corporation (hereinafter “Thermal”) warrants that its products will be free of defects in workmanship or material. Should any failure to conform to this warranty appear within the time period applicable to the Thermal products as stated below, Thermal shall, upon notification thereof and substantiation that the product has been stored, installed, operated, and maintained in accordance with Thermal’s specifications, instructions, recommendations and recognized standard industry practice, and not subject to misuse, repair, neglect, alteration, or accident, correct such defects by suitable repair or replacement, at Thermal’s sole option, of any components or parts of the product determined by Thermal to be defective.

This warranty is exclusive and is in lieu of any warranty of merchantability or fitness for a particular purpose.

LIMITATION OF LIABILITY: Thermal shall not under any circumstances be liable for special or consequential damages, such as, but not limited to, damage or loss of purchased or replacement goods, or claims of customers of distributor (hereinafter “Purchaser”) for service interruption. The remedies of the Purchaser set forth herein are exclusive and the liability of Thermal with respect to any contract, or anything done in connection therewith such as the performance or breach thereof, or from the manufacture, sale, delivery, resale, or use of any goods covered by or furnished by Thermal whether arising out of contract, negligence, strict tort, or under any warranty, or otherwise, shall not, except as expressly provided herein, exceed the price of the goods upon which such liability is based.

This warranty becomes invalid if replacement parts or accessories are used which may impair the safety or performance of any Thermal Product.

This warranty becomes invalid if the product is sold by non - authorized persons.

All SureLok[™] RPT Torches have a one year Parts & Labor warranty

Warranty repairs or replacement claims under this limited warranty must be submitted by an authorized Thermal Dynamics[®] repair facility within thirty (30) days of the repair. No transportation costs of any kind will be paid under this warranty. Transportation charges to send products to an authorized warranty repair facility shall be the responsibility of the customer. All returned goods shall be at the customer’s risk and expense.



THERMAL DYNAMICS[®]
A THERMADYNE[®] Company

Thermal Dynamics Corporation
82 Benning Street
West Lebanon, NH 03784 U.S.A.
1-800-Plasma-1
603-298-5711
www.thermal-dynamics.com

Section II

Adapter Kits

Contents

7-3425	7-3434	7-3443	7-3455	7-3481
7-3426	7-3435	7-3444	7-3456	7-3483
7-3427	7-3436	7-3445	7-3457	7-3484
7-3428	7-3437	7-3446	7-3461	7-3485
7-3429	7-3438	7-3447	7-3462	
7-3430	7-3439	7-3449	7-3476	
7-3431	7-3440	7-3450	7-3477	
7-3432	7-3441	7-3451	7-3478	
7-3433	7-3442	7-3454	7-3480	

1Torch™

with **SURELOK®** Technology

Adapter Kit Selection

Listed below is the Adapter Kit selection charts for the Hand 1Torch RPT torch.



Torch Adapter Kits

The model of the plasma cutting system must be known to determine the adapter kit required.

Manufacturer Power Supply Model	Catalog Number	Manufacturer Power Supply Model	Catalog Number
AIRCO®/BOC®		LINCOLN®	
PCS-43	7-3425	Pro-Cut 60	7-3431
PCS-53, PCS-80, PCS-90	7-3435	MARQUETTE®	
CEBORA®		12/150	7-3476
50	7-3438	MATCO®	
CENTURY®		2020, 2050	7-3476
82020, 82050	7-3476	MILLER®	
DAIHEN®		*Plazcut 60/Zipcut	7-3432
SC-60P	7-3432	Spectrum® 250D, 500, 750	7-3433
MRAT-70	7-3437	Spectrum® 700, 1000, 1250, PLUS	7-3430
DAYTON®		Spectrum® 3080	7-3456
3W722A, 5Z031B	7-3476	Spectrum® 650, 701, 2050	7-3457
ESAB® (yellow)		Spectrum® 300	7-3476
PCM-SMi, 500i, 625i, PCS-43	7-3425	Spectrum® 375	7-3477
PCS-53, 80, 90	7-3435	MULTIQUIP MQ®	
ESP-100i	7-3426	PCX50SS	7-3437
PCM-750i, 875, 1000i, 1125	7-3429	NU-TECSYS®	
Sidewinder 30, 55, 105	7-3434	Omnicut 375	7-3438
Powercut® 650, 875, 1125, 1250, 1500	7-3462	PCA-30/60, 65	7-3441
HARRIS®		OTC	
System 50, 65, 100	7-3439	Panasonic D-5000, D-7000	7-3437
HOBART®		P-TRON®	
Smoothcut 30, 625	7-3425	P-Tron 75, 100	7-3437
Smoothcut 50 (single gas), 100	7-3426	POWCON®	
Smoothcut 50 (dual gas)	7-3428	Starcut	7-3430
Smoothcut II 35A, 60A, 100A	7-3427	SMITH®	
Fab Shop	7-3440	SPC-30, 20-50, 40-80	7-3442
Cybercut 2050	7-3457	SNAP-ON®	
HYPERTHERM®		YA-2230, YA-5550	7-3476
Max® 40, HT® 40 (H/F Start)	7-3430	SOLAR®	
Max® 70, Max® 80, Max® 100 w/wo Q.D.		SOL 2020 (118-009, 118-010), SOL 2050 (118-015,118-016)	7-3476
Max® 42, 43, 40cs	7-3454	THERMAL DYNAMICS®	
powermax® 600, 800, 900		PAK® 3XR, 5XT, 5XR, 6XR, 7XR, 625XR, 750XR	7-3446
powermax® 1100	7-3455	PAK® 8XR, 10XR, 1000XR, 1250XR,	7-3434
powermax® 1000, 1250	7-3461	PakMaster® 75, 100	
Max® 40cs (wo/ Q.D.)	7-3476	PakMaster® 50XL/XLP, 75XL/XLP, 100XL/XLP	7-3447
powermax® 380	7-3477	CUTMASTER™ 50, 75, 80XL, 100	
INNERLOGIC®		PakMaster® 25, 38XL, EconoPAK® 25	7-3443
SR-45i	7-3451	Drag-Gun® 38, PAK® 4Xi, 6Xi	
L TEC® (green)		PAK® 2XT, Dynapak® 110	
PCM-31, SMi, 32i/34i, VPi	7-3425	PakMaster® 50 w/ Smart Torch (Q.D.)	7-3445
PCM-500i, 625i, PCS-80i		EconoPAK® 50	7-3449
PCM-50A, 70, 80, 52i/54i, 82i/84i	7-3426	EconoPAK® 100	7-3450
ESP-100i, PCM-50, PCM-100 (Single Gas)		PAK® 5	7-3444
PCM-50, PCM-100 (Dual Gas)		PAK® 10	7-3436
PCS-40	7-3430		
PCM-750i, 1000i	7-3435		
PCM-101	7-3436		

* The Miller PlazCut machines with Serial Numbers beginning JE are not compatible with 1Torch™ RPT Torches.

NOTES: Each Adapter Kit includes connection fitting, electrical connectors and installation instruction sheets for the selected power supply.

CEBORA is a registered trademark of Cebora S.p.A.; DAIHEN is a registered trademark of Daihen Inc.; ESAB and L-TEC are registered trademarks of ESAB AB; HARRIS and LINCOLN are registered trademarks of Lincoln Electric Co.; HOBART is a registered trademark of Hobart Brothers Co.; HYPERTHERM, Max and powermax are registered trademarks of Hypertherm, Inc.; MILLER and Spectrum are registered trademarks of Miller Electric Mfg. Co.; MULTIQUIP is a registered trademark of Multiquip, Inc.; NU-TECSYS is a registered trademark of Nu-Tecsys, Inc.; P-TRON is a registered trademark of P-Tron Plasma/Tech Systems; SMITH is a registered trademark of Smith Equipment Co.; INNERLOGIC is a trademark of Innerlogic; THERMAL DYNAMICS, PAK, CUTMASTER, PakMaster, EconoPAK, Dynapak and Drag-Gun are registered trademarks of Thermal Dynamics Corp.

1Torch Reference Guide

Components Required to upgrade to a 1Torch RPT Torch			THERMAL DYNAMICS® Plasma Systems		
RPT Torch	Adapter Kit	Spare Parts Kit	System Model	OEM Torch Model	Current Rating
SL60™	7-3443	5-2550	Drag-Gun 38	PCH25/38	29
SL60™	7-3446	5-2550	PAK 3XR	PCH-51	31
SL60™	7-3446	5-2552	PAK 5XT	PCH-51	50
SL60™	7-3446	5-2552	PAK 5XR	PCH-51	55
SL60™	7-3446	5-2552	PAK 625XR	PCH-51	55
SL60™/SL100™	7-3446	5-2554	PAK 6XR	PCH-51	65
SL60™/SL100™	7-3446	5-2554	PAK 750XR	PCH-51	65
SL60™/SL100™	7-3446	5-2554	PAK 7XR	PCH-52	70
SL100™	7-3434	5-2555	PAK 8XR	PCH-52	80
SL100™	7-3434	5-2555	PAK 1000XR	PCH-52	80
SL100™	7-3434	5-2556	PAK 10XR	PCH-52	105
SL100™	7-3434	5-2556	PAK 1250XR	PCH-52	105
PCH-42	7-3443	5-4204	PAK Master 25	PCH-25	20
SL60™	7-3443	5-2551	PAK Master 38XL	PCH25/38	29
SL60™	7-3445	5-2551	PAK Master 50	PCH-35	35
SL60™	7-3447	5-2551	PAK Master 50XL	PCH-28	35
SL60™	7-3447	5-2551	PAK Master 50XL Plus	PCH-40	40
SL60™	7-3447	5-2552	PAK Master 75	PCH-75	55
SL60™	7-3447	5-2552	PAK Master 75XL	PCH-75	55
SL60™	7-3447	5-2553	PAK Master 75XL Plus	PCH-60	60
SL60™/SL100™	7-3434	5-2554	PAK Master 100	PCH-53	70
SL60™/SL100™	7-3447	5-2554	PAK Master 100XL	PCH-100XL	70
SL100™	7-3447	5-2555	PAK Master 100XL Plus	PCH-80	80
SL60™	7-3447	5-2551	Cut Master 50	PCH-62	40
SL60™	7-3447	5-2553	Cut Master 80XL	PCH-75	60
SL60™	7-3447	5-2553	Cut Master 75	PCH-102	60
SL100™	7-3447	5-2555	Cut Master 100	PCH-102	80
PCH-42	7-3443	5-4204	EconoPak 25	PCH-25	20
SL60™	7-3449	5-2551	EconoPak 50	PCH-26	35
SL60™	7-3450	5-2553	EconoPak 100	PCH-76	60
PCH-42	7-3443	5-4204	Dyna-PAK 110	PCH-20	20
PCH-42	7-3443	5-4204	PAK 2XT	PCH-20	20
SL60™	7-3443	5-2551	PAK-4XI	PCH-51	40
SL60™	7-3443	5-2553	PAK-6XI	PCH-51	60
SL60™	7-3444	5-2552	PAK 5	PCH-50	50
SL100™	7-3436	5-2556	PAK 10	PCH-100, PCH-4B	100

1Torch Reference Guide

Components Required to upgrade to a 1Torch RPT Torch			ESAB / LTEC® Plasma Systems		
RPT Torch	Adapter Kit	Spare Parts Kit	System Model	OEM Torch Model	Current Rating
PCH-42	7-3425	5-4202	PCM-SMi	PT-31/31XL	14
SL60™	7-3425	5-2550	PCM-31	PT-31/31XL	30
SL60™	7-3425	5-2550	PCM-32/34i	PT-31/31XL	30
SL60™	7-3425	5-2551	PCM-VPI	PT-31/31XL	40
SL60™	7-3425	5-2550	PCM-500i	PT-31/31XL	35
SL60™	7-3425	5-2550	PCM-625i	PT-31/31XL	40
SL60™	7-3425	5-2551	PCS-40	PT-31/31XL	40
SL60™	7-3429	5-2552	PCM 750i (Yellow)	PT-27	50
SL60™	7-3435	5-2552	PCS-53	PCT-80	50
SL60™	7-3429	5-2553	PCM 875	PT-27	60
SL100™	7-3429	5-2555	PCM 1000i (Yellow)	PT-27	80
SL100™	7-3429	5-2555	PCM 1125	PT-27	80
SL100™	7-3435	5-2555	PCS-80	PCT-100	80
SL100™	7-3435	5-2556	PCS-90	PCT-100	90
SL100™	7-3426	5-2556	ESP100i	PT-25	100
SL60™	7-3434	5-2550	Sidewinder 30	PCH-51	30
SL60™	7-3434	5-2552	Sidewinder 55	PCH-51	55
SL100™	7-3434	5-2556	Sidewinder 105	PCH-52	105
SL60™	7-3426	5-2552	PCM-52/54i	PT-17/17A	50
SL60™	7-3428	5-2552	PCM-50	PT-17/17A	50
SL60™	7-3426	5-2552	PCM-50A	PT-17/17A	50
SL60™/SL100™	7-3426	5-2554	PCM-70	PT-17/17A	70
SL100™	7-3426	5-2555	PCM-80	PT-17/17A	80
SL100™	7-3425	5-2555	PCS-80i	PT-100	80
SL60™/SL100™	7-3426	5-2554	PCM-82/84i	PT-17/17A	70
SL100™	7-3426	5-2556	PCM-100 Single Gas	PT-17/17A	100
SL100™	7-3428	5-2556	PCM-100 Dual Gas	PT-17/17A	100
SL60™	7-3435	5-2552	PCM-750i (Green)	PT-27	50
SL100™	7-3435	5-2555	PCM-1000i (Green)	PT-27	80
SL60™	7-3464	5-2551	PowerCut 650	PT-31XLPC	40
SL60™	7-3464	5-2553	PowerCut 875	PT-32	60
SL100™	7-3464	5-2555	PowerCut 1125	PT-32	80
SL60™/SL100™	7-3462	5-2554	PowerCut 1250	PT-32EH	70
SL100™	7-3462	5-2556	PowerCut 1500	PT-32	90
SL100™	7-3436	5-2556	PCM-101	PT-101	100

Note: ESAB and LTEC offered numerous products with the same product name. Those that were not identical in design are designated Yellow for ESAB products and Green for LTEC products.

1Torch Reference Guide

Components Required to upgrade to a 1Torch RPT Torch			HARRIS® Plasma Systems		
RPT Torch	Adapter Kit	Spare Parts Kit	System Model	OEM Torch Model	Current Rating
SL60™	7-3439	5-2552	System 50		50
SL60™/SL100™	7-3439	5-2554	System 65		65
SL100™	7-3439	5-2556	System 100		100

Components Required to upgrade to a 1Torch RPT Torch			HOBART® Plasma Systems		
RPT Torch	Adapter Kit	Spare Parts Kit	System Model	OEM Torch Model	Current Rating
SL60™	7-3425	5-2550	Smoothcut 30	TP3A	30
SL60™	7-3425	5-2551	Smoothcut 625	PT-31	40
SL60™	7-3426	5-2552	Smoothcut 50(single gas)	PT-31	50
SL60™	7-3428	5-2552	Smoothcut 50(dual gas)	PT-17	50
SL60™	7-3427	5-2551	Smoothcut II 35A	HSC-30A	35
SL60™	7-3427	5-2553	Smoothcut II 60A	TP6A	60
SL100™	7-3427	5-2556	Smoothcut II 100A	TP10A	100
SL60™	7-3457	5-2553	Cybercut 2050	ICE-50C	50
SL100™	7-3440	5-2556	Fab Shop		100

Components Required to upgrade to a 1Torch RPT Torch			HYPER THERM® Plasma Systems		
RPT Torch	Adapter Kit	Spare Parts Kit	System Model	OEM Torch Model	Current Rating
SL60™	7-3430	5-2551	Max40 (H/F Start)	PAC140	40
SL60™/SL100™	7-3430	5-2554	Max 70 (w/wo Q.D.)	PAC130	70
SL100™	7-3430	5-2555	Max 80 (w/wo Q.D.)	PAC130	80
SL100™	7-3430	5-2556	Max 100 (w/wo Q.D.)	PAC130	100
SL60™	7-3476	5-2551	Max 40cs (wo/ Q.D.)	PAC120	40
SL60™	7-3454	5-2551	Max 40cs	PAC120	40
SL60™	7-3454	5-2551	Max 42	PAC120	35
SL60™	7-3454	5-2551	Max 43	PAC120	35
SL60™	7-3485	5-2550	powermax 190C	PAC105T	12
SL60™	7-3484	5-2550	powermax 350	PAC110T	25
SL60™	7-3477	5-2550	powermax 380	PAC110T	25
SL60™	7-3454	5-2551	powermax 600	PAC123	35
SL60™	7-3480	5-2551	powermax 600 (wo/ Q.D.)	PAC123	35
SL60™	7-3454	5-2552	powermax 800	PAC121	50
SL60™	7-3481	5-2552	powermax 800 (wo/ Q.D.)	PAC121	50
SL60™	7-3454	5-2552	powermax 900	PAC125	55
SL60™	7-3481	5-2552	powermax 900 (wo/ Q.D.)	PAC125	55
SL100™	7-3455	5-2555	powermax 1100	PAC135	80
SL60™	7-3461	5-2553	powermax 1000	T60	60
SL100™	7-3461	5-2555	powermax 1250	T80	80
SL100™	7-3483	5-2556	powermax 1650	T100	100

1Torch Reference Guide

Components Required to upgrade to a 1Torch RPT Torch			LINCOLN® Plasma Systems		
RPT Torch	Adapter Kit	Spare Parts Kit	System Model	OEM Torch Model	Current Rating
SL60™	7-3431	5-2551	Procut 40	PCT-40	40
SL60™	7-3431	5-2553	Procut 60	PCT-60	60

Components Required to upgrade to a 1Torch RPT Torch			MILLER® Plasma Systems		
Torch	Kit	Parts Kit	System Model	Model	Rating
SL60™	7-3432	5-2552	Plazcut 60/Zipcut	APT-1000	50
SL60™	7-3433	5-2550	Spectrum 250D	APT-3000	30
SL60™	7-3477	5-2550	Spectrum 375	ICE-27C	27
SL60™	7-3433	5-2552	Spectrum 500	APT-5000	50
SL60™	7-3478	5-2551	Spectrum 625	ICE-40C	40
SL60™	7-3430	5-2552	Spectrum 700	ICE-50	50
SL60™	7-3433	5-2552	Spectrum 750	ICE-50	50
SL60™/SL100™	7-3430	5-2554	Spectrum 1000	ICM-70/100	70
SL100™	7-3430	5-2556	Spectrum 1250, PLUS	ICM-70/100	100
SL60™	7-3457	5-2552	Spectrum 650	ICE-50C	50
SL60™	7-3457	5-2552	Spectrum 701	ICE-50C	50
SL60™	7-3457	5-2552	Spectrum 2050	ICE-50/55C	55
SL100™	7-3456	5-2555	Spectrum 3080	ICE-80C	80
SL100™	7-3430	5-2555	Spectrum PLUS	ICM-70/100	85

Components Required to upgrade to a 1Torch RPT Torch			OTC® (Panasonic) Plasma Systems		
Torch	Kit	Parts Kit	System Model	Model	Rating
SL60™	7-3437	5-2550	D5000		30
SL60™	7-3437	5-2552	D7000		50

Components Required to upgrade to a 1Torch RPT Torch			PTRON® Plasma Systems		
RPT Torch	Adapter Kit	Spare Parts Kit	System Model	OEM Torch Model	Current Rating
SL60™	7-3437	5-2553	P-Tron 75		60
SL60™/SL100™	7-3437	5-2555	P-Tron 100		80

1Torch Reference Guide

Components Required to upgrade to a 1Torch RPT Torch			POWCON® Plasma Systems		
RPT Torch	Adapter Kit	Spare Parts Kit	System Model	OEM Torch Model	Current Rating
SL100™	7-3430	5-2556	Starcut		100

Components Required to upgrade to a 1Torch RPT Torch			SMITH® Plasma Systems		
RPT Torch	Adapter Kit	Spare Parts Kit	System Model	OEM Torch Model	Current Rating
SL60™	7-3442	5-2550	SPC-30		30
SL60™	7-3442	5-2552	SPC-20-50		50
SL100™	7-3442	5-2555	SPC-40-80		80

Components Required to upgrade to a 1Torch RPT Torch			CEBORA® Plasma Systems		
RPT Torch	Adapter Kit	Spare Parts Kit	System Model	OEM Torch Model	Current Rating
SL60™	7-3476	5-2550	Pocket 25		25
SL60™	7-3438	5-2552	50		50

Components Required to upgrade to a 1Torch RPT Torch			DAIHEN® Plasma Systems		
RPT Torch	Adapter Kit	Spare Parts Kit	System Model	OEM Torch Model	Current Rating
SL60™	7-3432	5-2553	SC-60P		60
SL60™/SL100™	7-3437	5-2554	MRAT-70		70

Components Required to upgrade to a 1Torch RPT Torch			MULTIQUIP® Plasma Systems		
RPT Torch	Adapter Kit	Spare Parts Kit	System Model	OEM Torch Model	Current Rating
SL60™	7-3437	5-2552	PCX50SS		50

Components Required to upgrade to a 1Torch RPT Torch			NU-TECSYS® Plasma Systems		
RPT Torch	Adapter Kit	Spare Parts Kit	System Model	OEM Torch Model	Current Rating
SL60™	7-3438	5-2551	Omnicut 375		40
SL60™	7-3441	5-2553	PCA-30/60		60
SL60™/SL100™	7-3441	5-2554	PCA-65		65

Please call Thermal Dynamics Technical Services for any system not found listed.

1Torch Reference Guide

Components Required to upgrade to a 1Torch RPT Torch			INNERLOGIC® Plasma Systems		
RPT Torch	Adapter Kit	Spare Parts Kit	System Model	OEM Torch Model	Current Rating
SL100™	7-3451	5-2552	SR45i		45

Components Required to upgrade to a 1Torch RPT Torch			AIRCO/BOC® Plasma Systems		
RPT Torch	Adapter Kit	Spare Parts Kit	System Model	OEM Torch Model	Current Rating
SL60™	7-3425	5-2551	PCS-43		40
SL60™	7-3435	5-2552	PCS-53	PCT-80	50

Components Required to upgrade to a 1Torch RPT Torch			CENTURY® Plasma Systems		
RPT Torch	Adapter Kit	Spare Parts Kit	System Model	OEM Torch Model	Current Rating
SL60™	7-3476	5-2550	82020		20
SL60™	7-3476	5-2552	82050		50
SL60™	7-3476	5-2552	M2050		50

Components Required to upgrade to a 1Torch RPT Torch			DAYTON® Plasma Systems		
RPT Torch	Adapter Kit	Spare Parts Kit	System Model	OEM Torch Model	Current Rating
SL60™	7-3476	5-2550	3W722A		20
SL60™	7-3476	5-2552	5Z031B		50

Components Required to upgrade to a 1Torch RPT Torch			MATCO® Plasma Systems		
Torch	Kit	Parts Kit	System Model	Model	Rating
SL60™	7-3476	5-2550	2020		20
SL60™	7-3476	5-2552	2050		50

Components Required to upgrade to a 1Torch RPT Torch			SOLAR® Plasma Systems		
RPT Torch	Adapter Kit	Spare Parts Kit	System Model	OEM Torch Model	Current Rating
SL60™	7-3476	5-2550	Sol 2020		20
SL60™	7-3476	5-2552	Sol 2050		50
SL60™	7-3476	5-2552	20-50		50

Please call Thermal Dynamics Technical Services for any system not found listed.

1Torch Reference Guide

Components Required to upgrade to a 1Torch RPT Torch			SNAP-ON® Plasma Systems		
RPT Torch	Adapter Kit	Spare Parts Kit	System Model	OEM Torch Model	Current Rating
SL60™	7-3476	5-2550	YA-2230		30
SL60™	7-3476	5-2552	YA-5550		50
SL60™	7-3476	5-2552	YA-5550A		50
SL100™	7-3430	5-2556	YA-3440		100

Components Required to upgrade to a 1Torch RPT Torch			MARQUETTE® Plasma Systems		
RPT Torch	Adapter Kit	Spare Parts Kit	System Model	OEM Torch Model	Current Rating
SL60™	7-3476	5-2550	12/150		30
SL60™	7-3476	5-2552	12/200		50

Components Required to upgrade to a 1Torch RPT Torch					
RPT Torch	Adapter Kit	Spare Parts Kit	System Model	OEM Torch Model	Current Rating

Components Required to upgrade to a 1Torch RPT Torch					
RPT Torch	Adapter Kit	Spare Parts Kit	System Model	OEM Torch Model	Current Rating

Components Required to upgrade to a 1Torch RPT Torch					
Torch	Kit	Parts Kit	System Model	Model	Rating

Components Required to upgrade to a 1Torch RPT Torch					

**Adapter Kit
Numerical List**

Catalog No.	Description	Manufacturer	Systems
7-3425	RPT Torch Adapter Kit	BOC(Airco)	PCS-43
		Esab	PCM-SMi, 500i, 625i, PCS-43
		Hobart	Smoothcut 30, 625
		L-Tec	PCM-31, SMi, 32i/34i, Vpi, PCM-500i, 625i, PCS-80i
7-3426	RPT Torch Adapter Kit	Esab	ESP-100i
		Hobart	50 (single gas), 100
		L-Tec	PCM-50A, 70, 80, 52i/54i, 82i/84i, ESP-100i, PCM-50, PCM-100 (Single Gas), PCM-50, PCM-100 (Dual Gas)
7-3427	RPT Torch Adapter Kit	Hobart	Smoothcut II 35A, 60A, 100A
7-3428	RPT Torch Adapter Kit	Hobart	Smoothcut 50 (dual gas)
7-3429	RPT Torch Adapter Kit	L-Tec	PCM-750i, 875, 1000i, 1125
7-3430	RPT Torch Adapter Kit	Hypertherm	Max® 40, HT® 40 (H/F Start), Max® 70, Max® 80, Max® 100 w/ & w/o Q.D
		L-Tec	PCS-40
		Miller	Spectrum® 700, 1000, 1250, PLUS
		Powcon	Starcut
		Snap-On	3440
7-3431	RPT Torch Adapter Kit	Lincoln	Pro-Cut 60
7-3432	RPT Torch Adapter Kit	Daihen	SC-60P
		Miller	Plazcut 60/Zipcut
7-3433	RPT Torch Adapter Kit	Miller	Spectrum® 250D, 500, 750
7-3434	RPT Torch Adapter Kit	Thermal Dynamics	PAK® 8XR, 10XR, 1000XR, 1250XR, PakMaster® 75, 100
7-3435	RPT Torch Adapter Kit	BOC(Airco)	PCS-53, PCS-80, PCS-90
		Esab	PCS-53, PCS-80, PCS-90
		Hobart	Smoothcut 30, 625
		L-Tec	PCM-31, SMi, 32i/34i, Vpi, PCM-500i, 625i, PCS-80i, PCM-750i, 1000i
7-3436	RPT Torch Adapter Kit	Thermal Dynamics	PAK® 10
		L-Tec	PCM-101
7-3437	RPT Torch Adapter Kit	Daihen	MRAT-70
		Multiquip	PCX50SS
		P-Tron	P-Tron 75, 100
7-3438	RPT Torch Adapter Kit	Cebora	50
		Nu-Tecsys	Omnicut 375
7-3439	RPT Torch Adapter Kit	Harris	System 50, 65, 100
7-3440	RPT Torch Adapter Kit	Hobart	Fabshop
7-3441	RPT Torch Adapter Kit	Nu-Tecsys	PCA-30/60, 65
7-3442	RPT Torch Adapter Kit	Smith	SPC-30, 20-50, 40-80
7-3443	RPT Torch Adapter Kit	Thermal Dynamics	PakMaster® 25, 38XL, EconoPAK® 25, Drag-Gun® 38, PAK® 4Xi, 6Xi, PAK® 2XT, Dynapak® 110
7-3444	RPT Torch Adapter Kit	Thermal Dynamics	PAK® 5

**Adapter Kit
Numerical List**

Catalog No.	Description	Manufacturer	Systems
7-3445	RPT Torch Adapter Kit	Thermal Dynamics	PakMaster® 50 w/ Smart Torch (Q.D.)
7-3446	RPT Torch Adapter Kit	Thermal Dynamics	PAK® 3XR, 5XT, 5XR, 6XR, 7XR, 625XR, 750XR
7-3447	RPT Torch Adapter Kit	Thermal Dynamics	PakMaster® 50XL/XLP, 75XL/XLP, 100XL/XLP, CUTMASTER™ 50, 75, 80XL, 100
7-3448	RPT Torch Adapter Kit	N/A	N/A
7-3449	RPT Torch Adapter Kit	Thermal Dynamics	EconoPAK® 50
7-3450	RPT Torch Adapter Kit	Thermal Dynamics	EconoPAK® 100
7-3451	RPT Torch Adapter Kit	Innerlogic	SR-45i
7-3452	RPT Torch Adapter Kit	All	Mechanized Interface
7-3454	RPT Torch Adapter Kit	Hypertherm	Max® 42,43,40cs, powermax® 600, 800, 900
7-3455	RPT Torch Adapter Kit	Hypertherm	powermax® 1100
7-3456	RPT Torch Adapter Kit	Miller	Spectrum® 3080
7-3457	RPT Torch Adapter Kit	Miller	Spectrum® 650, 701, 2050
7-3461	RPT Torch Adapter Kit	Hypertherm	powermax® 1000, 1250
7-3462	RPT Torch Adapter Kit	Esab	Powercut 1250, 1500
7-3472	RPT Torch Adapter Kit	All	ATC Receptacle Adapter-shielded
7-3474	RPT Torch Adapter Kit	All	ATC Interface Adapter
7-3476	RPT Torch Adapter Kit	Century	82020, 82050, M2050
		Dayton	3W722A, 5Z031B
		Marquette	12/150, 12/200
		Matco	2020, 2050
		Snap-On	YA-2230, YA-5550, YA-5550A
		Solar	SOL 2020 (118-009, 118-010), SOL 2050* (118-015,118-016)
7-3477	RPT Torch Adapter Kit	Hypertherm	powermax® 380
		Miller	Spectrum® 375
7-3478	RPT Torch Adapter Kit	Miller	Spectrum® 625
7-3480	RPT Torch Adapter Kit	Hypertherm	powermax® 600 w/o Q.D.
7-3481	RPT Torch Adapter Kit	Hypertherm	powermax® 800, 900 w/o Q.D.
7-3483	RPT Torch Adapter Kit	Hypertherm	powermax® 1650
7-3484	RPT Torch Adapter Kit	Hypertherm	powermax® 350
7-3485	RPT Torch Adapter Kit	Hypertherm	powermax® 190C
7-5207	RPT Torch Adapter Kit	All	ATC Receptacle Adapter-standard

General Information

This Replacement Torch Adapter Kit is to be used to connect the Thermal Dynamics Plasma RPT Series Cutting Torch to the following equipment:

- HOBART SMOOTHCUT 30 and 625
- L-TEC PCM-31, 32i/34i, VPi, 500i, 625I, SMi and PCS-80i
- ESAB SMi and PCS-43

Parts Supplied

The following parts are included in this kit:

- Control Connector Plug with Connectors - 1 ea
- Adapter Fitting - 1 ea
- Pilot Adapter Fitting - 1 ea
- Protective Boot - 1 ea

Installation

Install the Adapter Kit per the following procedure:

1. Turn OFF the power supply.
2. Disconnect the main input power to the power supply.
3. Remove the existing torch from the power supply, removing covers as required.
4. Slide the Protective Boot, included in this kit, over the end of the Negative / Plasma Lead.
5. Place the Adapter Fitting provided into the Power Supply torch power cable fitting (-) and tighten securely.

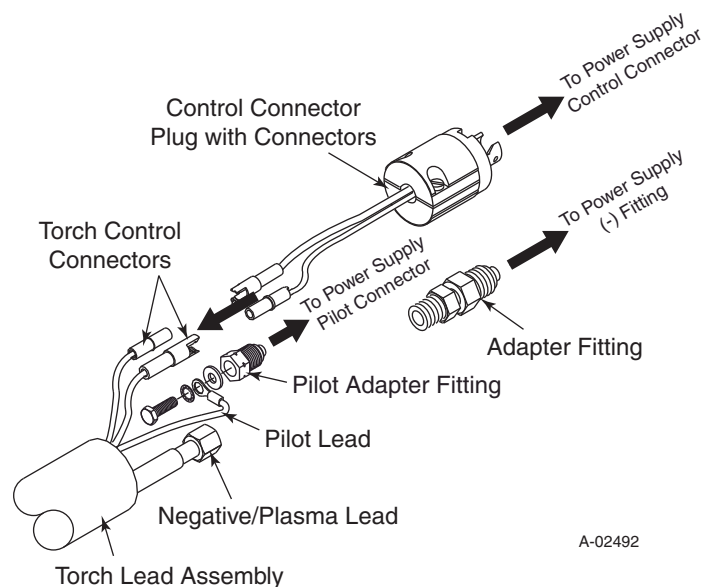

6. The Pilot Adapter Fitting is only used on Pilot Arc Systems. Do one of the following:
 - On Pilot Arc Systems install the the Pilot Adapter Fitting onto the Power Supply Pilot Connection.
 - For HF Torch Start Systems the Pilot Adapter Fitting is not used.
7. Pilot wire connection is made only on Pilot Arc Systems. Do one of the following:
 - On Pilot Arc Systems connect the pilot wire (+) from the replacement torch to the Power Supply Pilot Adapter Fitting. Secure the wire with the bolt and washers provided.
 - For HF Torch Start Systems the wire is not connected. Apply electrical tape over the end of pilot wire.
8. Connect the Negative / Plasma Lead from the replacement torch to the Power Supply. Slide the protective boot over the lead connection.
9. Connect the Control Connector Plug, with two connectors, to the two mating connectors on the replacement torch leads, see NOTE.
10. Connect the Control Connector Plug to the Power Supply.
11. Reinstall any covers removed, see WARNING.
12. Install the proper torch consumables for the Power Supply amperage.
13. Reconnect input power and turn ON the unit.
14. Set proper gas pressure or flow.
15. Test torch for proper operation.

NOTE

For Mechanized Systems refer to the Torch Control Cable Wiring Diagrams in the Manual supplied with the RPT Torch.



WARNING

Make sure that the Control Connector Plug wires DO NOT contact the Adapter Fitting after all leads are connected.

NOTE

Every effort has been made to provide complete and accurate information in this manual. However, the publisher does not assume and hereby disclaims any liability to any party for any loss or damage caused by errors or omissions in this manual, whether such errors result from negligence, accident or any other cause.

7-3425

RPT Adapter Kit

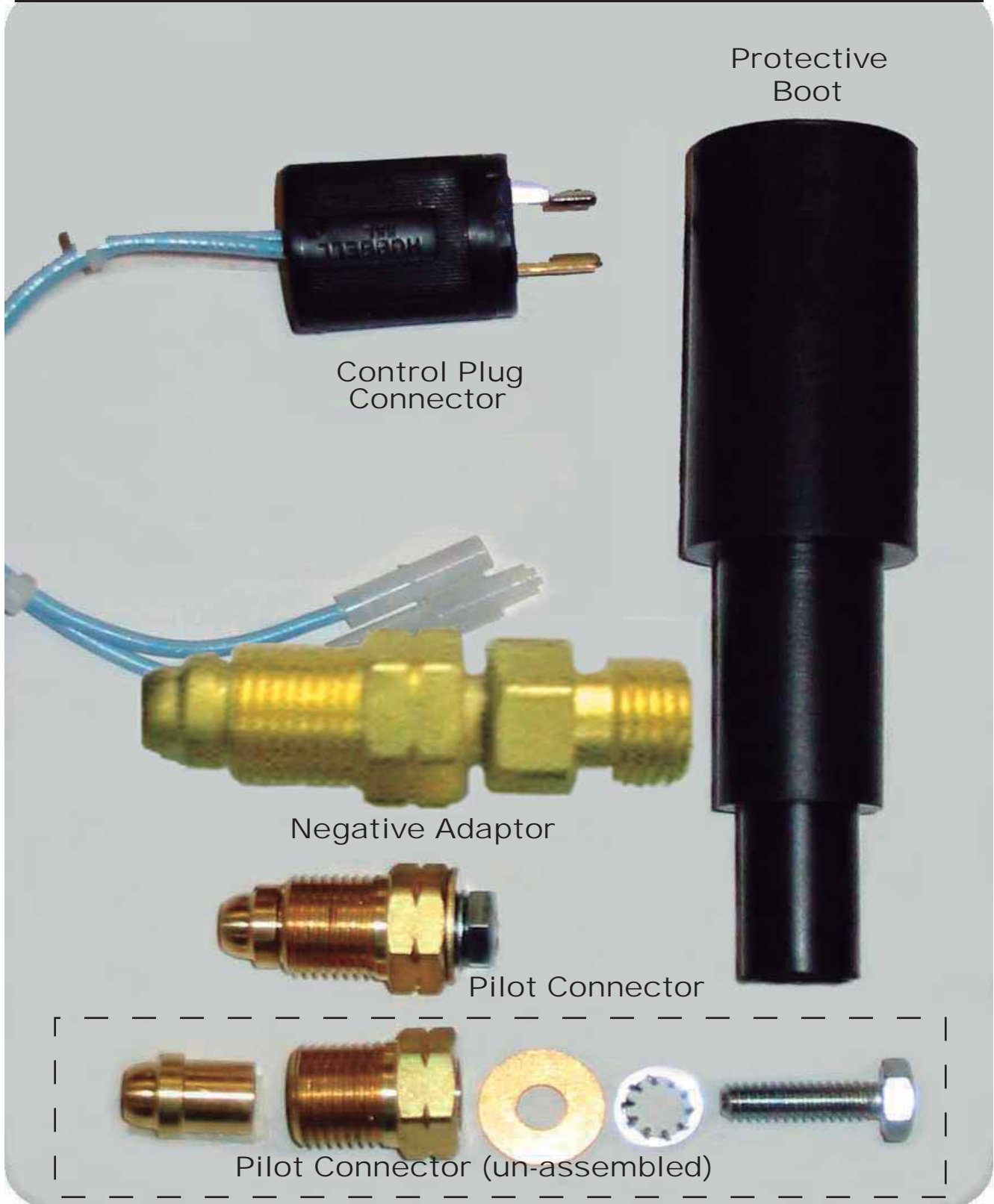

General Information

This Replacement Torch Adapter Kit is to be used to connect the Thermal Dynamics Plasma RPT Series Cutting Torch to the following equipment:

- ESAB EPS-100i
- HOBART SMOOTHCUT 50, Single Gas, and SMOOTHCUT 1000
- L-TEC PCM-50A, 70, 80, 82i, 84i, 100, Single Gas, ESP-100I and 52i/54i
- L-TEC PCM-50 and PCM-100, Dual Gas

Parts Supplied

The following parts are included in this kit:

- Control Connector Plug with Connectors - 1 ea
- Adapter Fitting - 1 ea
- Pilot Adapter Fitting - 1 ea
- Protective Boot - 1 ea

Installation

Install the Adapter Kit per the following procedure:

1. Turn OFF the power supply.
2. Disconnect the main input power to the power supply.
3. Remove the existing torch from the power supply, removing covers as required.
4. Slide the Protective Boot, included in this kit, over the end of the Negative / Plasma Lead.
5. Place the Adapter Fitting provided into the Power Supply torch power cable fitting (-) and tighten securely.

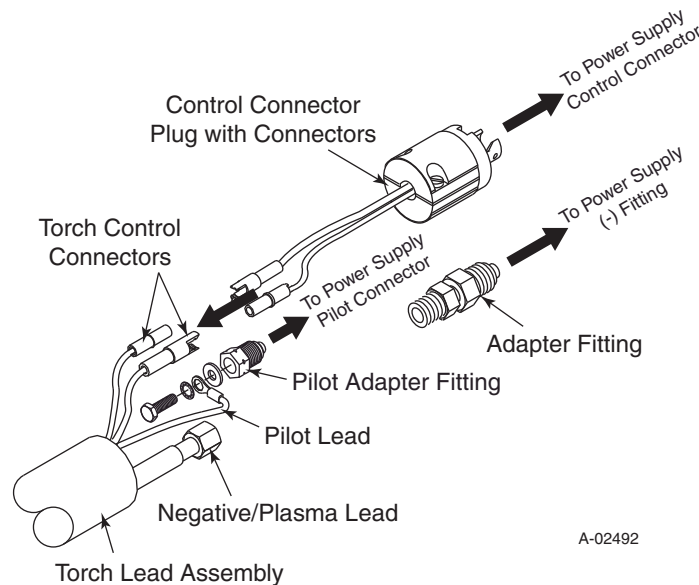

A-02492

6. The Pilot Adapter Fitting is only used on Pilot Arc Systems. Do one of the following:
 - On Pilot Arc Systems install the the Pilot Adapter Fitting onto the Power Supply Pilot Connection.
 - For HF Torch Start Systems the Pilot Adapter Fitting is not used.
7. Pilot wire connection is made only on Pilot Arc Systems. Do one of the following:
 - On Pilot Arc Systems connect the pilot wire (+) from the replacement torch to the Power Supply Pilot Adapter Fitting. Secure the wire with the bolt and washers provided.
 - For HF Torch Start Systems the wire is not connected. Apply electrical tape over the end of pilot wire.
8. Connect the Negative / Plasma Lead from the replacement torch to the Power Supply. Slide the protective boot over the lead connection.
9. Connect the Control Connector Plug, with two connectors, to the two mating connectors on the replacement torch leads, see NOTE.
10. Connect the Control Connector Plug to the Power Supply.
11. Reinstall any covers removed, see WARNING.
12. Install the proper torch consumables for the Power Supply amperage.
13. Reconnect input power and turn ON the unit.
14. Set proper gas pressure or flow.
15. Test torch for proper operation.

NOTE

For Mechanized Systems refer to the Torch Control Cable Wiring Diagrams in the Manual supplied with the RPT Torch.



WARNING

Make sure that the Control Connector Plug wires DO NOT contact the Adapter Fitting after all leads are connected.

NOTE

Every effort has been made to provide complete and accurate information in this manual. However, the publisher does not assume and hereby disclaims any liability to any party for any loss or damage caused by errors or omissions in this manual, whether such errors result from negligence, accident or any other cause.

7-3426

RPT Adapter Kit



Control Plug Connector



Negative Adaptor



Pilot Connector



Protective Boot



Pilot Connector (un-assembled)

General Information

This Replacement Torch Adapter Kit is to be used to connect the Thermal Dynamics Plasma RPT Series Cutting Torch to the following equipment:

- HOBART SMOOTHCUT II 35A, 60A and 100A

Parts Supplied

The following parts are included in this kit:

- Control Connector Plug with Connectors - 1 ea
- Protective Boot - 1 ea

Installation

Install the Adapter Kit per the following procedure:

1. Turn OFF the power supply.
2. Disconnect the main input power to the power supply.
3. Remove the existing torch from the power supply, removing covers as required.
4. Slide the Protective Boot, included in this kit, over the end of the Negative / Plasma Lead.
5. Connect the pilot wire (+) from the replacement torch to the Power Supply and tighten securely. For 35A machines the pilot wire is not required and must be secured out of the way.
6. Connect the Negative / Plasma Lead from the replacement torch to the Power Supply. Slide the protective boot over the lead connection.

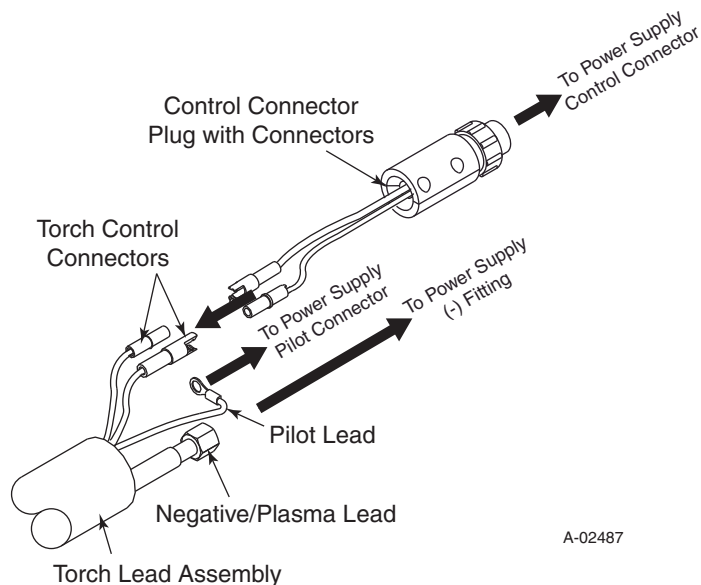

A-02487

7. Connect the Control Connector Plug, with two connectors, to the two mating connectors on the replacement torch leads, see NOTE.
8. Connect the Control Connector Plug to the Power Supply.
9. Reinstall any covers removed, see WARNING.
10. Install the proper torch consumables for the Power Supply amperage.
11. Reconnect input power and turn ON the unit.
12. Set proper gas pressure or flow.
13. Test torch for proper operation.

NOTE

For Mechanized Systems refer to the Torch Control Cable Wiring Diagrams in the Manual supplied with the RPT Torch.



WARNING

Make sure that the Control Connector Plug wires DO NOT contact the Adapter Fitting after all leads are connected.

NOTE

Every effort has been made to provide complete and accurate information in this manual. However, the publisher does not assume and hereby disclaims any liability to any party for any loss or damage caused by errors or omissions in this manual, whether such errors result from negligence, accident or any other cause.

Torch Control Cable Wiring Diagram For Mechanized Systems

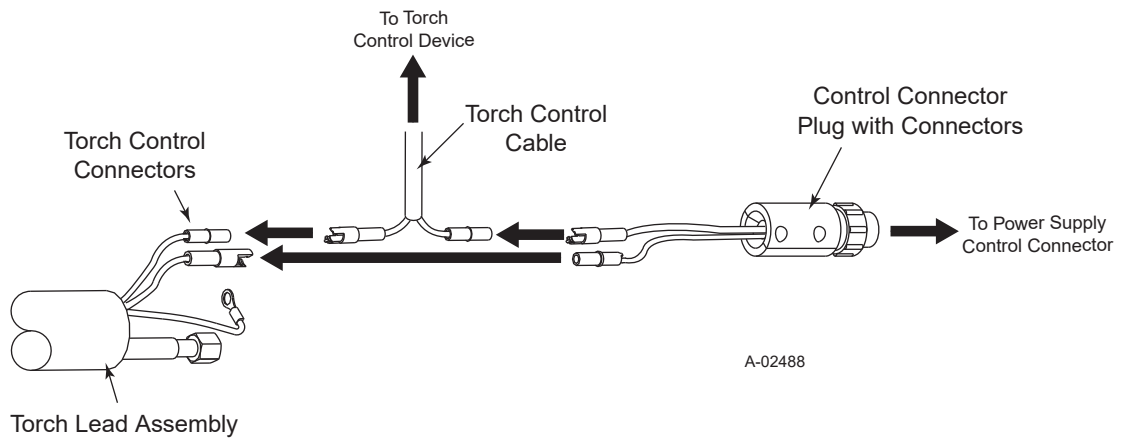

NOTE

Every effort has been made to provide complete and accurate information in this manual. However, the publisher does not assume and hereby disclaims any liability to any party for any loss or damage caused by errors or omissions in this manual, whether such errors result from negligence, accident or any other cause.

7-3427

RPT Adapter Kit



Protective
Boot
(not shown)

Control Plug
Connector

General Information

This Replacement Torch Adapter Kit is to be used to connect the Thermal Dynamics Plasma RPT Series Cutting Torch to the following equipment:

- HOBART SMOOTHCUT 50, Dual Gas

Parts Supplied

The following parts are included in this kit:

- Control Connector Plug with Connectors - 1 ea
- Adapter Fitting - 1 ea
- Pilot Adapter Fitting - 1 ea
- Protective Boot - 1 ea

Installation

Install the Adapter Kit per the following procedure:

1. Turn OFF the power supply.
2. Disconnect the main input power to the power supply.
3. Remove the existing torch from the power supply, removing covers as required.
4. Slide the Protective Boot, included in this kit, over the end of the Negative / Plasma Lead.
5. Place the Adapter Fitting provided into the Power Supply torch power cable fitting (-) and tighten securely.
6. Install the Pilot Adapter Fitting onto the Power Supply pilot connection.

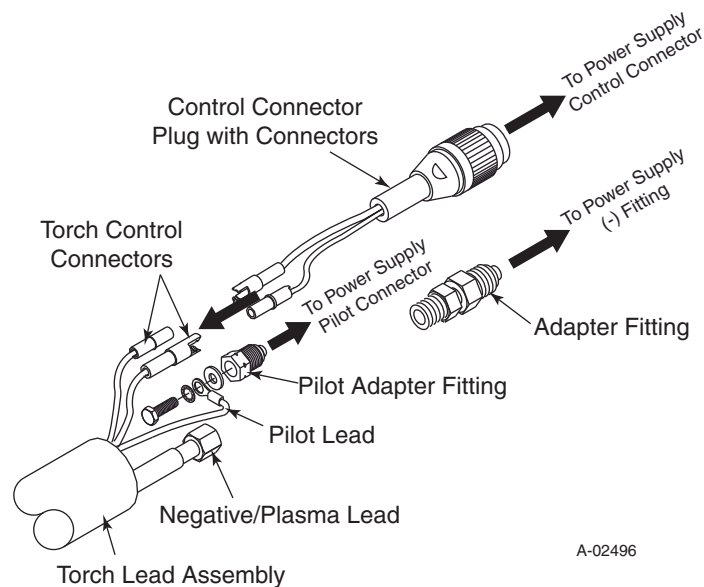

A-02496

7. Connect the pilot wire (+) from the replacement torch to the Power Supply Pilot Adapter Fitting. Secure the wire with the bolt and washers provided.
8. Connect the Negative / Plasma Lead from the replacement torch to the Power Supply. Slide the protective boot over the lead connection.
9. Connect the Control Connector Plug, with two connectors, to the two mating connectors on the replacement torch leads, see NOTE.
10. Connect the Control Connector Plug to the Power Supply.
11. Reinstall any covers removed, see WARNING.
12. Install the proper torch consumables for the Power Supply amperage.
13. Reconnect input power and turn ON the unit.
14. Set proper gas pressure or flow.
15. Test torch for proper operation.

NOTE

For Mechanized Systems refer to the Torch Control Cable Wiring Diagrams in the Manual supplied with the RPT Torch.



WARNING

Make sure that the Control Connector Plug wires DO NOT contact the Adapter Fitting after all leads are connected.

NOTE

Every effort has been made to provide complete and accurate information in this manual. However, the publisher does not assume and hereby disclaims any liability to any party for any loss or damage caused by errors or omissions in this manual, whether such errors result from negligence, accident or any other cause.

7-3428

RPT Adapter Kit



Negative Adaptor

Protective Boot
(not shown)

Control Plug Connector

Pilot Connector

CONTACTOR LEAD

General Information

This Replacement Torch Adapter Kit is to be used to connect the Thermal Dynamics Plasma RPT Series Cutting Torch to the following equipment:

- ESAB 750I, 875I and 1000i

Parts Supplied

The following parts are included in this kit:

- Control Connector Plug with Connectors - 1 ea
- Adapter Fitting - 1 ea
- Ring Terminal - 1 ea
- Protective Boot - 1 ea

Installation

Install the Adapter Kit per the following procedure:

1. Turn OFF the power supply.
2. Disconnect the main input power to the power supply.
3. Remove the existing torch from the power supply, removing covers as required.
4. Slide the Protective Boot, included in this kit, over the end of the Negative / Plasma Lead.
5. Place the Adapter Fitting provided into the Power Supply torch power cable fitting (-) and tighten securely.
6. Connect the pilot wire (+) from the replacement torch to the Power Supply and tighten securely. If required, use the ring terminal provided.

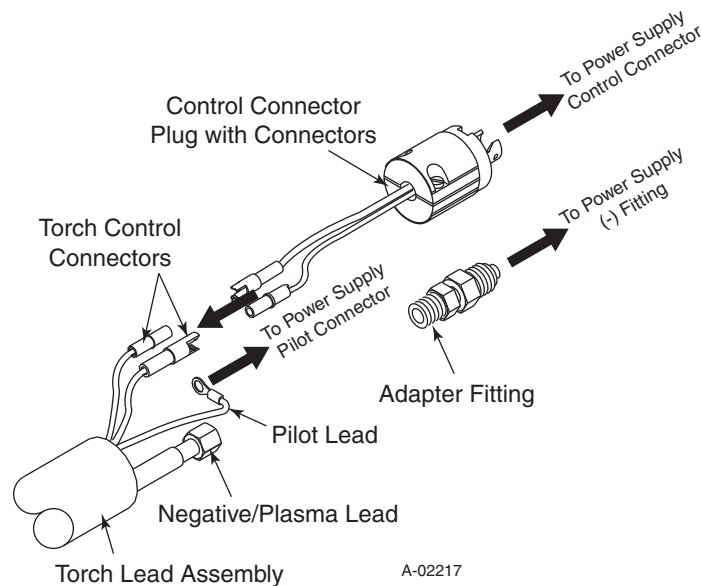

Torch Control Cable Wiring Diagram For Mechanized Systems

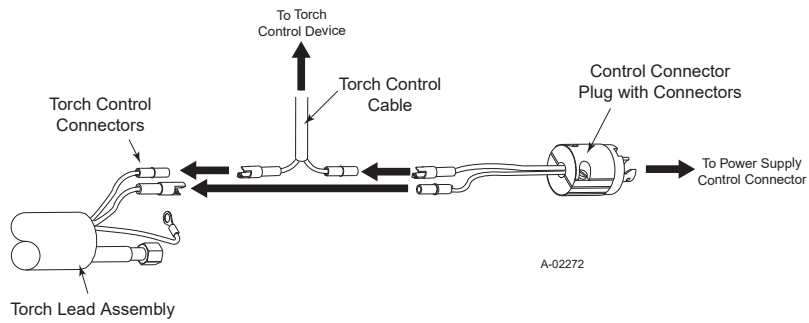

NOTE

Every effort has been made to provide complete and accurate information in this manual. However, the publisher does not assume and hereby disclaims any liability to any party for any loss or damage caused by errors or omissions in this manual, whether such errors result from negligence, accident or any other cause.

7-3429

RPT Adapter Kit



Protective
Boot

Negative Adaptor

Pilot Connector

General Information

This Replacement Torch Adapter Kit is to be used to connect the Thermal Dynamics Plasma RPT Series Cutting Torch to the following equipment:

- HYPERTHERM MAX 40 HF Start, MAX 70, MAX 80 and MAX 100
- L-TEC PCS-40
- MILLER SPECTRUM 700, 1000, 1250, PLUS
- POWCON STARCUT

Parts Supplied

The following parts are included in this kit:

- Control Connector Wire with Connectors & Spade Lugs - 1 ea
- Control Connector Wire with Connectors & Fastons - 2 ea
- Adapter Fitting - 1 ea
- Pilot Adapter Fitting - 1 ea
- Insulating Sleeve - 1 ea
- In-Line Splice - 1 ea
- Protective Boot - 1 ea
- Restrictor Pin Kit No. 8-3440

NOTE

This kit includes parts that are not used in all applications. Read these directions carefully to determine whether all parts are needed.

Installation on Power Supplies Without Quick Disconnect

Install the Adapter Kit as follows:

1. Turn OFF the power supply.
2. Disconnect the main input power to the power supply.
3. Remove the existing torch from the power supply, removing covers as required.
4. Slide the Protective Boot, included in this kit, over the end of the Negative / Plasma Lead.
5. Place the Adapter Fitting provided into the Power Supply torch power cable fitting (-) and tighten securely.
6. Install the Pilot Adapter Fitting onto the Power Supply pilot connection.
7. Connect the pilot wire (+) from the replacement torch to the Power Supply Pilot Adapter Fitting. Secure the wire with the bolt and washers provided.

8. Connect the Negative / Plasma Lead from the replacement torch to the Power Supply. Slide the protective boot over the lead connection.
9. Connect the Control Connector Plug, with two connectors, to the two mating connectors on the replacement torch leads, see NOTE.

NOTE

For Mechanized Systems refer to the Torch Control Cable Wiring Diagram Without Quick Disconnect on the last page of this Manual.

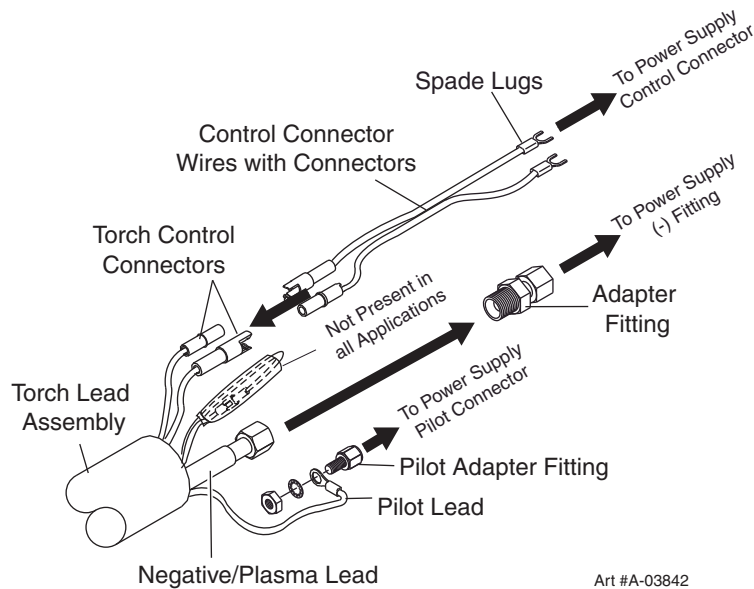

10. Connect the spade lugs of the Control Connector Wires to the Power Supply.
11. Reinstall any covers removed, see WARNING.



Make sure that the Control Connector Plug wires DO NOT contact the Adapter Fitting after all leads are connected.

12. **When using this kit to connect a Model SL60 or SL100 torch to any of the listed Miller Spectrum power supplies (ONLY):** Install a restrictor pin in any starter cartridge to be used with a Model SL60 or SL100 torch, according to the separate instructions provided with restrictor pin kit No. 8-3440 included in this Adapter Kit.
13. Install the proper torch consumables for the Power Supply amperage.
14. Reconnect input power and turn ON the unit.
15. Set proper gas pressure or flow.
16. Test torch for proper operation.

Installation on Power Supplies With Quick Disconnect

Install the Adapter Kit as follows:

1. Turn OFF the power supply.
2. Disconnect the main input power to the power supply.
3. Remove the existing torch from the power supply at the quick disconnect.
4. Disassemble the quick disconnect at the end of the original torch. Set the original torch aside.
5. Install the Adapter Fitting provided on to the quick disconnect power cable fitting (-) and tighten securely.
6. Install the Pilot Adapter Fitting onto the quick disconnect pilot Connection.
7. Connect the pilot wire (+) from the replacement torch to the Pilot Adapter Fitting. Secure with the nut and washer provided, see Note.

NOTE

The Pilot Lead may need to be shortened to allow the quick disconnect to be reassembled.

8. Slide the Protective Boot, included in this kit, over the end of the Negative / Plasma Lead.
9. Slide the Insulating Sleeve, provided, over the Negative / Plasma Lead and inside the Protective Boot.
10. Connect the Negative / Plasma Lead from the replacement torch to the Adapter Fitting installed on the quick disconnect. Slide the Insulating Sleeve over the lead connection, then slide the protective boot over the lead connection.
11. Connect the short Control Connector Wires, with two faston connectors, to the two mating connectors on the replacement torch leads.
12. Connect the fastons of the Control Connector Wires to the mating connectors on the quick disconnect.
13. Reassemble the quick disconnect, see WARNING, and connect to the Power Supply.



WARNING

Make sure that the Control Connector Plug wires DO NOT contact the Adapter Fitting after all leads are connected.

14. On mechanized systems connect the remote start command to the Power Supply, see NOTE.

NOTE

For Mechanized Systems refer to the Torch Control Cable Wiring Diagram with Quick Disconnect on the last page of this manual.

15. **When using this kit to connect a Model SL60 or SL100 torch to any of the listed Miller Spectrum power supplies (ONLY):** Install a restrictor pin in any starter cartridge to be used with a Model SL60 or SL100 torch, according to the separate instructions provided in restrictor pin kit No. 8-3440 included in this Adapter Kit.
16. Install the proper torch consumables for the Power Supply amperage.
17. Reconnect input power to the Power Supply and turn ON the unit.
18. Set proper gas pressure or flow.
19. Test torch for proper operation.



WARNING

Replacing Original Machine Torch with TDC RPT Mechanized Torch

Thermal Dynamics RPT mechanized torches have two control wires that are used for Parts-In-Place, PIP, only. Do not connect these PIP connections directly into any start input because when the torch parts are in place, the start signal will always be energized. If the torch parts are not in place but are subsequently installed with the start signal energized, the shield cup will complete the start circuit and the unit will immediately transfer a pilot arc.

Torch Control Cable Wiring Diagram For Mechanized Systems Without Quick Disconnect

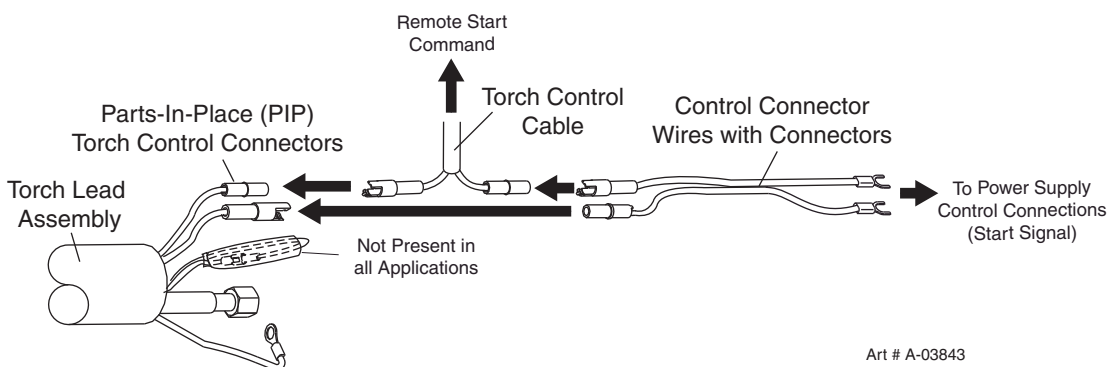

Torch Control Cable Wiring Diagram For Mechanized Systems With Quick Disconnect

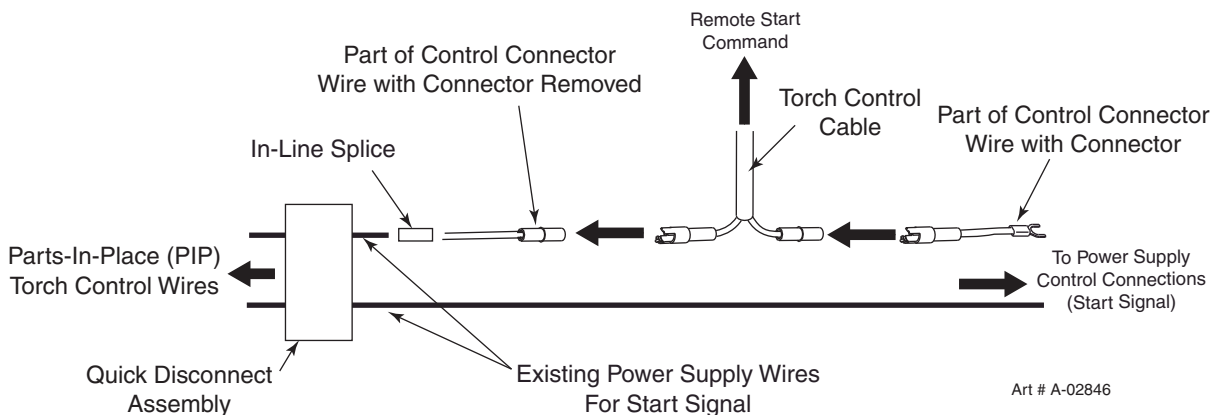

NOTE

Every effort has been made to provide complete and accurate information in this manual. However, the publisher does not assume and hereby disclaims any liability to any party for any loss or damage caused by errors or omissions in this manual, whether such errors result from negligence, accident or any other cause.

7-3430

RPT Adapter Kit

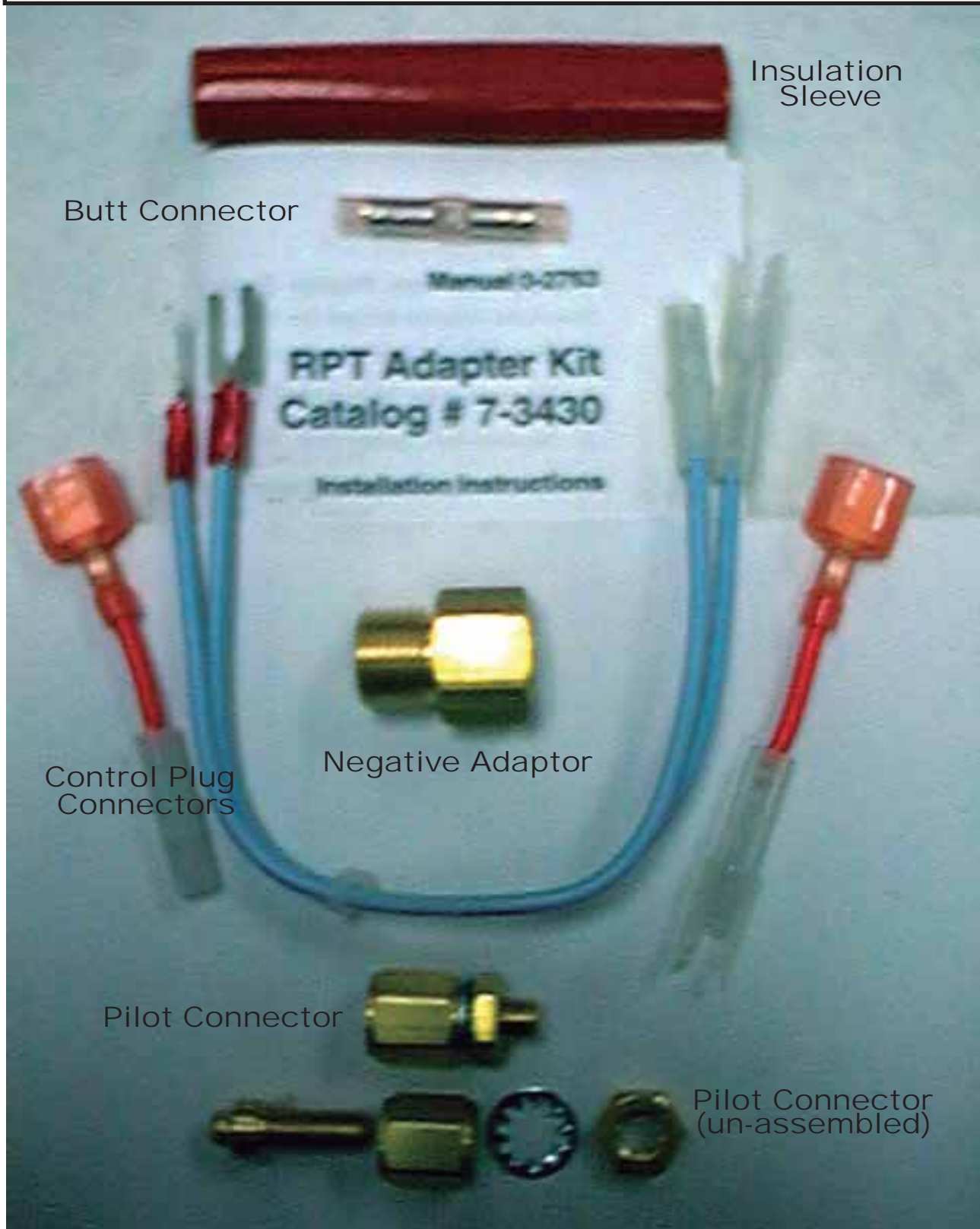

RPT Adapter Kit Catalog # 7-3431

Installation Instructions

General Information

This Replacement Torch Adapter Kit is to be used to connect the Thermal Dynamics Plasma RPT Series Cutting Torch to the following equipment:

Lincoln PROCUT 60

Parts Supplied

The following parts are included in this kit:

- Control Connector Plug with Connectors (1 ea)
- Adapter Fitting (1 ea)

Installation

Install the Adapter Kit per the following procedure:

1. Turn OFF the power supply.
2. Disconnect the main input power to the power supply.
3. Remove the existing torch from the power supply, removing covers as required.
4. Place the Adapter Fitting provided into the Power Supply torch power cable fitting (-) and tighten securely.
5. Connect the pilot wire (+) from the replacement torch to the Power Supply and tighten securely.
6. Connect the Negative/Plasma Lead from the replacement torch to the Adapter Fitting.
7. Connect the Control Connector Plug (see NOTE), with two connectors, to the two mating connectors on the replacement torch leads.
8. Connect the Control Connector Plug to the Power Supply.
9. Reinstall any covers removed (see WARNING).
10. Install the proper torch consumables for the Power Supply amperage.
11. Reconnect main input power to the Power Supply and turn the unit ON.
12. Set air pressure to 60 - 70 psi (4.1 - 4.8 bar).
13. Test torch for proper operation.

NOTE
For Mechanized Systems refer to the Torch Control Cable Wiring Diagram on the last page of this Manual.

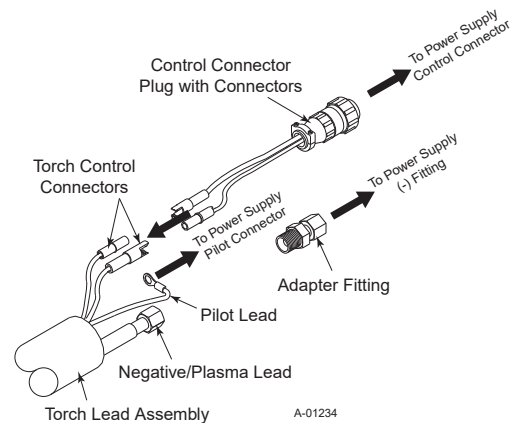

WARNING

Make sure that the Control Connector Plug wires DO NOT contact the Adapter Fitting after all leads are connected.

Torch Control Cable Wiring Diagram For Mechanized Systems

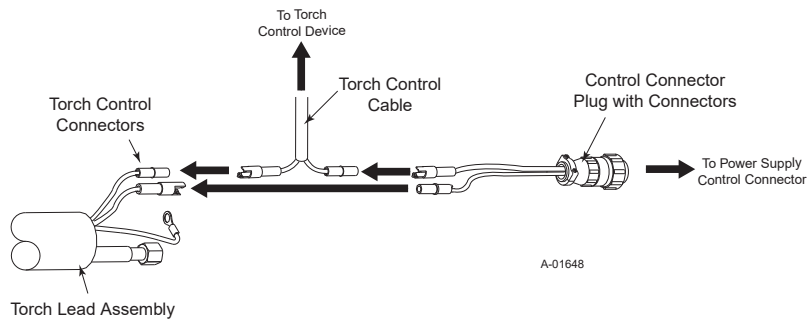

NOTE

Every effort has been made to provide complete and accurate information in this manual. However, the publisher does not assume and hereby disclaims any liability to any party for any loss or damage caused by errors or omissions in this manual, whether such errors result from negligence, accident or any other cause.

7-3431

RPT Adapter Kit



Negative Adaptor

Control Plug
Connector

General Information

This Replacement Torch Adapter Kit connects the Thermal Dynamics Plasma RPT Series Cutting Torch to the following equipment:

DAIHEN SC-60P

MILLER Plazcut 60 / Zipcut

Parts Supplied

The kit includes:

- Control Connector Plug with Connectors
- Adapter Fittings (2)

Installation

Install the Adapter Kit as follows:

1. Turn OFF the power supply.
2. Disconnect the main input power to the power supply.
3. Remove the existing torch from the power supply, removing covers as required.
4. Place the appropriate Adapter Fitting into the Power Supply torch power cable fitting (-) and tighten securely. Do not use thread sealant. Retain the unused fitting for possible future use.
5. Connect the pilot wire (+) from the replacement torch to the Power Supply and tighten securely.
6. Connect the Negative / Plasma Lead from the replacement torch to the Adapter Fitting. Slide the protective boot over the lead connection.
7. Connect the Control Connector Plug (see NOTE), with two connectors, to the two mating connectors on the replacement torch leads.
8. Connect the Control Connector Plug to the Power Supply.

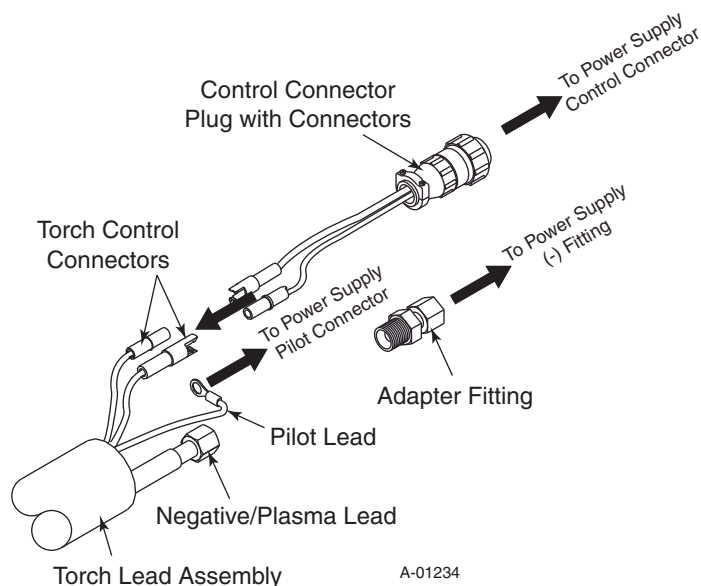

A-01234



WARNING

Make sure that the Control Connector Plug wires DO NOT contact the Adapter Fitting after all leads are connected.

9. Reinstall any covers removed (see WARNING).
10. Install the proper torch consumables for the Power Supply amperage.
11. Reconnect input power to the Power Supply and ON turn the unit.
12. Set gas pressure and flow according to directions in the torch manual.
13. Test torch for proper operation.

Torch Control Cable Wiring Diagram For Mechanized Systems

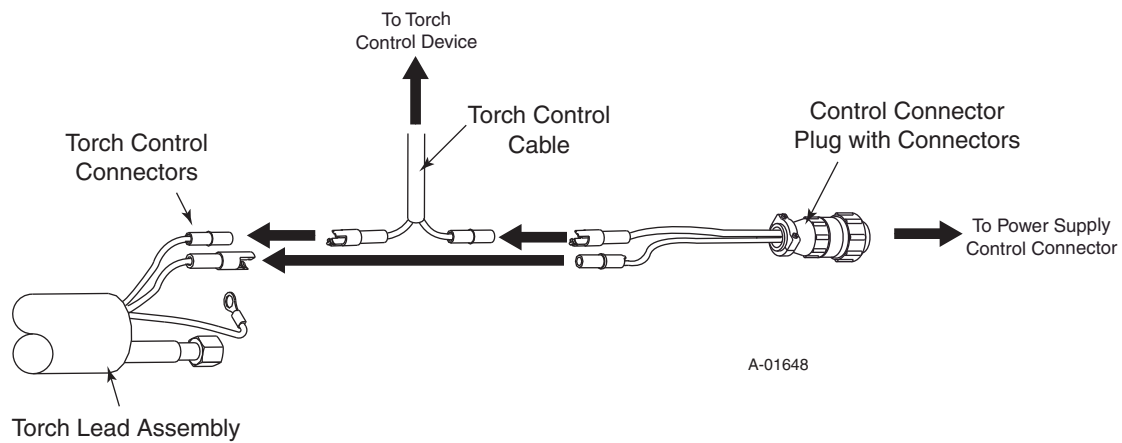

NOTE

Every effort has been made to provide complete and accurate information in this manual. However, the publisher does not assume and hereby disclaims any liability to any party for any loss or damage caused by errors or omissions in this Manual, whether such errors result from negligence, accident, or any other cause.

7-3432

RPT Adapter Kit





82 Benning Street, West Lebanon, NH 03784 USA
(603) 298-5711 • www.thermal-dynamics.com

Manual 0-2759

RPT Adapter Kit Catalog # 7-3433

Installation Instructions

General Information

This Replacement Torch Adapter Kit is to be used to connect the Thermal Dynamics Plasma RPT Series Cutting Torch to the following equipment:

MILLER* SPECTRUM* 250, 500 and 750

Parts Supplied

The kit includes:

- Control Connector Wire Harness
- Insulating Sleeve
- Tie Wrap (2)

Installation

Install the Adapter Kit as follows:

1. Turn OFF the power supply.
2. Disconnect the main input power to the power supply.
3. Remove the existing torch from the power supply, removing covers as required.
4. Connect the pilot wire (+) from the replacement torch to the Power Supply and tighten securely. On smaller Spectrum machines without a pilot stud, connect the pilot wire to trigger terminal #1.
5. Connect the Negative / Plasma Lead from the replacement torch to the Power Supply. Slide the protective boot over the lead connection.

6. Connect the Control Connector Wires (see NOTE), with two connectors, to the two mating connectors on the replacement torch leads.

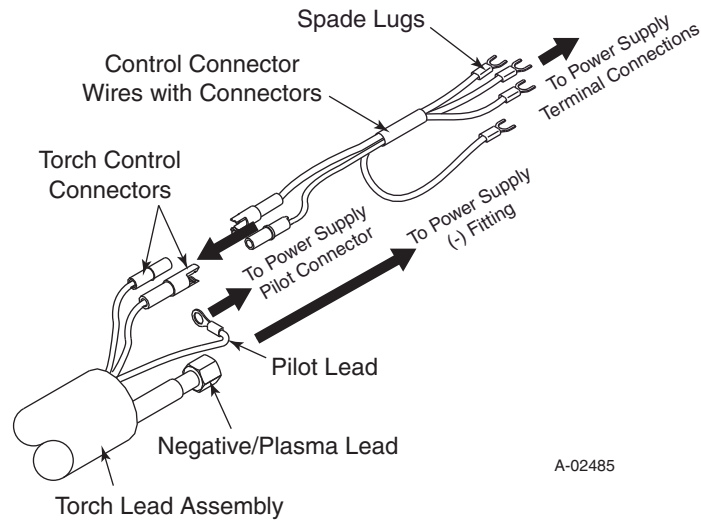

NOTE

For Mechanized Systems refer to the Torch Control Cable Wiring Diagram on the last page of this Manual.

7. **When connecting a SL60 or SL100 torch to a Spectrum 500 or Spectrum 700 Power Supply:**
 - a. Refer to the Power Supply Manufacturer's manual for location of Relay Board PC2. Refer to the Relay Board illustration. Disconnect power supply wire from terminal B on Power Supply relay board PC2.
 - b. Install the insulating sleeve provided in this kit on the wire connection removed from terminal B.
 - c. Secure the sleeve in place with wire ties supplied in this kit.

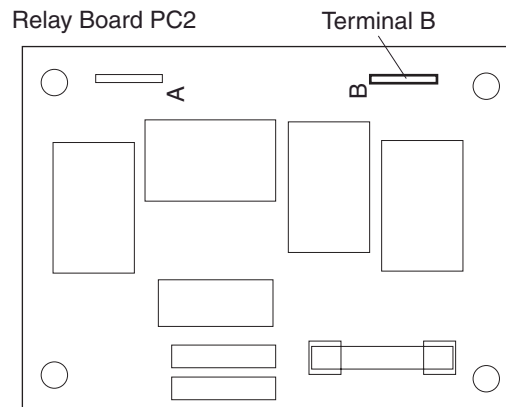

8. **All Applications:** Connect the spade lugs of the Control Connector Harness Wires to the Power Supply as follows:

Wire No.	Terminal No.
1	1
2	2
3	3
4	4

7-3433

RPT Adapter Kit



General Information

This Replacement Torch Adapter Kit is to be used to connect the Thermal Dynamics Plasma RPT Series Cutting Torch to the following equipment:

- ESAB SIDEWINDER 50, SIDEWINDER 55 and SIDEWINDER 105
- Thermal Dynamics PAK 8XR, 10XR, 1000XR, and 1250XR
- Thermal Dynamics PakMaster 50, internal connection, and PakMaster 100

Parts Supplied

The following parts are included in this kit:

- Control Connector Plug with Connectors - 1 ea
- Secondary Gas Output Plug - 1 ea
- Strain Relief - 1 ea

Installation

Install the Adapter Kit per the following procedure:

1. Turn OFF the power supply.
2. Disconnect the main input power to the power supply.
3. Remove the existing torch from the power supply, removing covers as required.
4. The Strain Relief included in this kit is a device to prevent damage to the Torch Leads resulting from a direct through panel exposure. All plasma cutting systems may not be equipped to utilize this Strain Relief.

On units where the Strain Relief can be used, install as follows:

- a. Remove the retaining nut from the Strain Relief.
- b. Place the end of the Strain Relief into the hole in the unit.
- c. Secure the Strain Relief to the Power Supply with the retaining nut.
- d. Loosen the leads capture nut on the outside of the Strain Relief.
- e. Feed the torch lead ends through the Strain Relief and into the unit.
- f. Tighten the leads capture nut to secure the Strain Relief onto the Torch Leads.

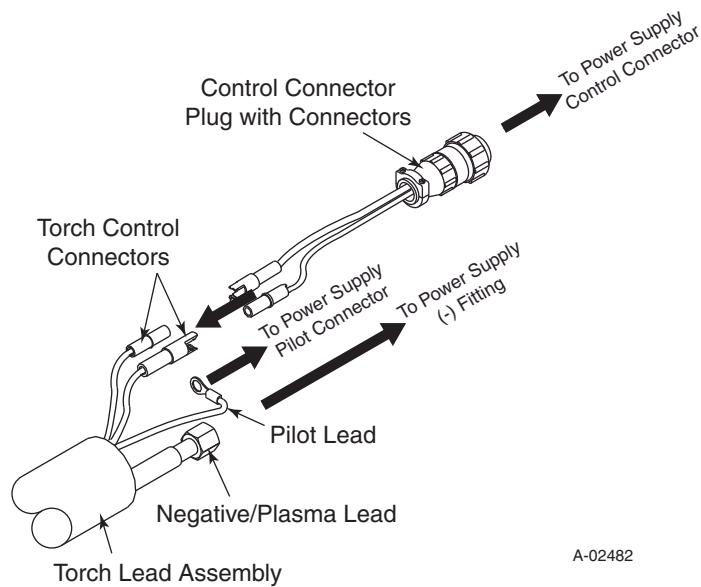

5. Connect the pilot wire (+) from the replacement torch to the Power Supply and tighten securely.
6. Connect the Negative / Plasma Lead from the replacement torch to the Power Supply. Slide the protective boot over the lead connection.
7. Connect the Control Connector Plug, with two connectors, to the two mating connectors on the replacement torch leads, see NOTE.
8. Connect the Control Connector Plug to the Power Supply.
9. For dual gas machines, install the supplied left-handed Secondary Gas Output Plug to block off the secondary gas output. Secondary gas pressure must be supplied to the Power Supply to activate the secondary gas circuit.
10. Reinstall any covers removed, see WARNING.
11. Install the proper torch consumables for the Power Supply amperage.
12. Reconnect input power and turn ON the unit.
13. Set proper gas pressure or flow.
14. Test torch for proper operation.

NOTE

For Mechanized Systems refer to the Torch Control Cable Wiring Diagrams in the Manual supplied with the RPT Torch.



WARNING

Make sure that the Control Connector Plug wires DO NOT contact the Adapter Fitting after all leads are connected.

NOTE

Every effort has been made to provide complete and accurate information in this manual. However, the publisher does not assume and hereby disclaims any liability to any party for any loss or damage caused by errors or omissions in this manual, whether such errors result from negligence, accident or any other cause.

7-3434

RPT Adapter Kit

RPT Adapter Kit
Catalog # 7-3434

Control Plug
Connector



Pilot Connector

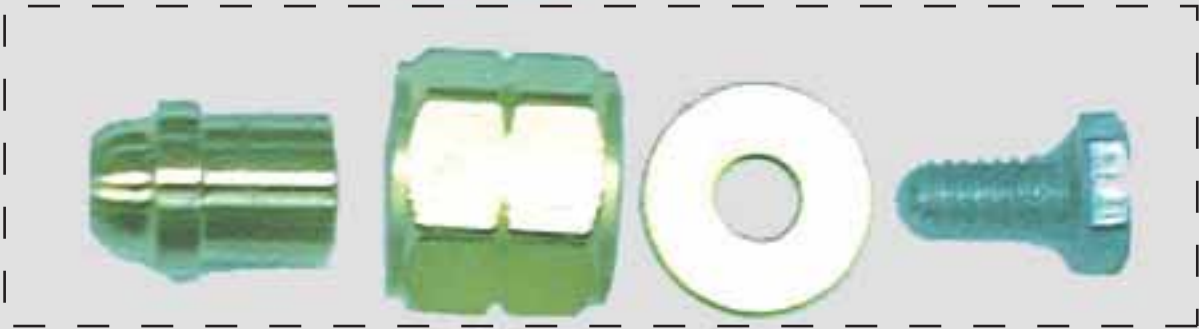

Pilot Connector (un-assembled)

General Information

This Replacement Torch Adapter Kit is to be used to connect the Thermal Dynamics Plasma RPT Series Cutting Torch to the following equipment:

- L-TEC PCM-750i, Green Unit, and PCM-1000I, Green Unit
- ESAB PCS-53, 80 and 90

Parts Supplied

The following parts are included in this kit:

- Control Connector Plug with Connectors - 1 ea
- Adapter Fitting - 1 ea
- Pilot Connector Plug - 1 ea
- Pilot Connector Jumper Wire - 1 ea
- Protective Boot - 1 ea

Installation

Install the Adapter Kit per the following procedure:

1. Turn OFF the power supply.
2. Disconnect the main input power to the power supply.
3. Remove the existing torch from the power supply, removing covers as required.
4. Slide the Protective Boot, included in this kit, over the end of the Negative / Plasma Lead.
5. Place the Adapter Fitting provided into the Power Supply torch power cable fitting (-) and tighten securely.

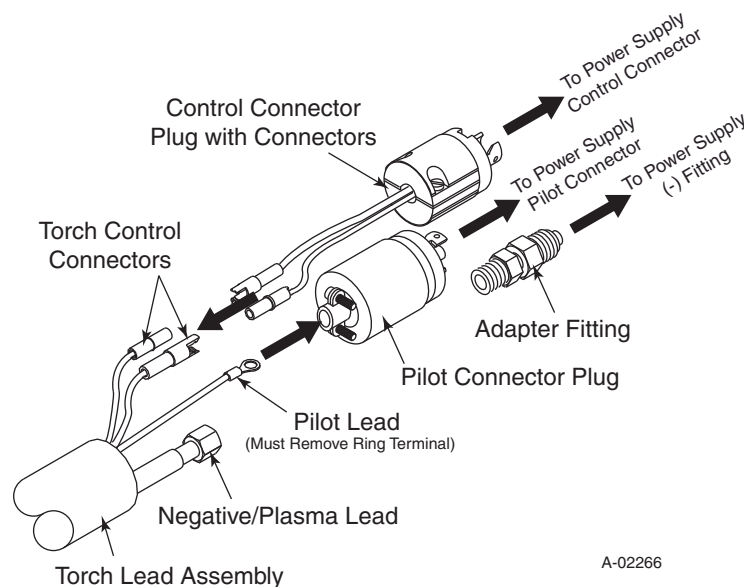

A-02266

6. Cut the ring terminal off the pilot lead of the replacement torch.
7. Remove the two screws from the Pilot Connector Plug. Open the connector and insert the end of the Torch Pilot Lead wire into either one of the outside terminals. **DO NOT insert pilot wire into center terminal.** Insert one end of the supplied Pilot Connector Jumper Wire into the same terminal as the Torch Pilot Lead. Insert the other end of the Pilot Connector Jumper Wire into the other outside terminal. Re-install the two screws. Connect the Pilot Connector Plug to the Power Supply.
8. Connect the Negative / Plasma Lead from the replacement torch to the Power Supply. Slide the protective boot over the lead connection.
9. Connect the Control Connector Plug, with two connectors, to the two mating connectors on the replacement torch leads, see NOTE.
10. Connect the Control Connector Plug to the Power Supply.
11. Reinstall any covers removed, see WARNING.
12. Install the proper torch consumables for the Power Supply amperage.
13. Reconnect input power and turn ON the unit.
14. Set proper gas pressure or flow.
15. Test torch for proper operation.

NOTE

For Mechanized Systems refer to the Torch Control Cable Wiring Diagrams in the Manual supplied with the RPT Torch.



WARNING

Make sure that the Control Connector Plug wires DO NOT contact the Adapter Fitting after all leads are connected.

NOTE

Every effort has been made to provide complete and accurate information in this manual. However, the publisher does not assume and hereby disclaims any liability to any party for any loss or damage caused by errors or omissions in this manual, whether such errors result from negligence, accident or any other cause.

Torch Control Cable Wiring Diagram For Mechanized Systems

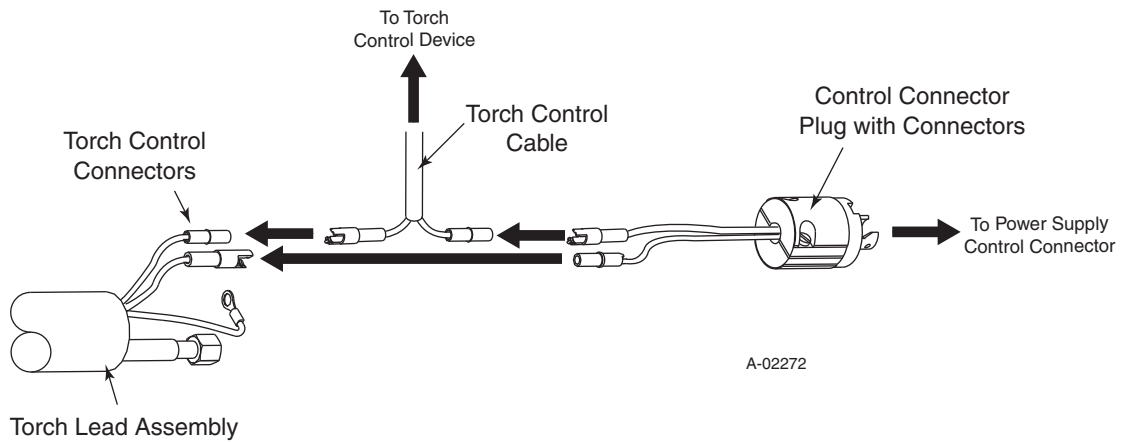

NOTE

Every effort has been made to provide complete and accurate information in this manual. However, the publisher does not assume and hereby disclaims any liability to any party for any loss or damage caused by errors or omissions in this manual, whether such errors result from negligence, accident or any other cause.

7-3435

RPT Adapter Kit

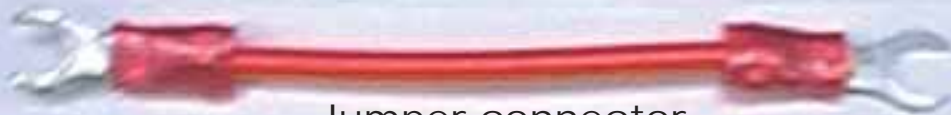

Jumper connector

Manual 0-2730

RPT Adapter Kit
Catalog # 7-3435

Negative Adaptor

Installation Instructions



Control Plug
Connector



Pilot Connector

RPT Adapter Kit Catalog # 7-3436

Installation Instructions

General Information

This Replacement Torch Adapter Kit is to be used to connect the Thermal Dynamics Plasma RPT Series Cutting Torch to the following equipment:

- L-TEC PCM-101
- Thermal Dynamics PAK 10

Parts Supplied

The following parts are included in this kit:

- Control Connector Plug with Connectors (1 ea)
- Secondary Gas Plug/Pilot Adapter Fitting (1 ea)

Installation

Install the Adapter Kit per the following procedure:

1. Turn OFF the power supply.
2. Disconnect the main input power to the power supply.
3. Remove the existing torch from the power supply, removing covers as required.
4. Install the supplied Secondary Gas Plug/Pilot Adapter Fitting (left-handed thread) onto the Power Supply.
5. Connect the pilot wire (+) from the replacement torch to the Power Supply Secondary Gas Plug/Pilot Adapter Fitting with the bolt and washer provided and tighten securely.
6. Connect the Negative/Plasma Lead from the replacement torch to the Power Supply. Slide the protective boot over the lead connection.
7. Connect the Control Connector Plug (see NOTE), with two connectors, to the two mating connectors on the replacement torch leads.
8. Connect the Control Connector Plug to the Power Supply.
9. Reinstall any covers removed (see WARNING).
10. Install the proper torch consumables for the Power Supply amperage.
11. Reconnect main input power to the Power Supply and turn the unit ON. Secondary gas pressure must be supplied to the Power Supply to activate the secondary gas circuit.
12. Set air pressure to 60 - 70 psi (4.1 - 4.8 bar).
13. Test torch for proper operation.

NOTE
<i>For Mechanized Systems refer to the Torch Control Cable Wiring Diagram on the last page of this Manual.</i>

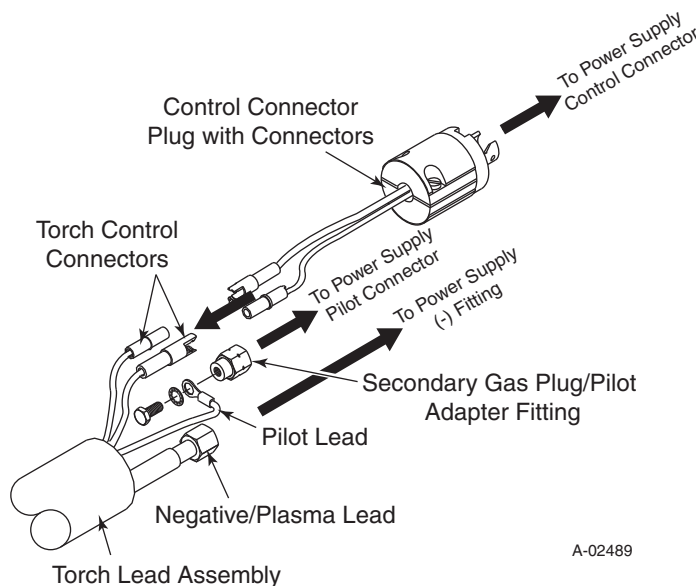

A-02489

 WARNING
<p><i>Make sure that the Control Connector Plug wires DO NOT contact the Adapter Fitting after all leads are connected.</i></p>

Torch Control Cable Wiring Diagram For Mechanized Systems

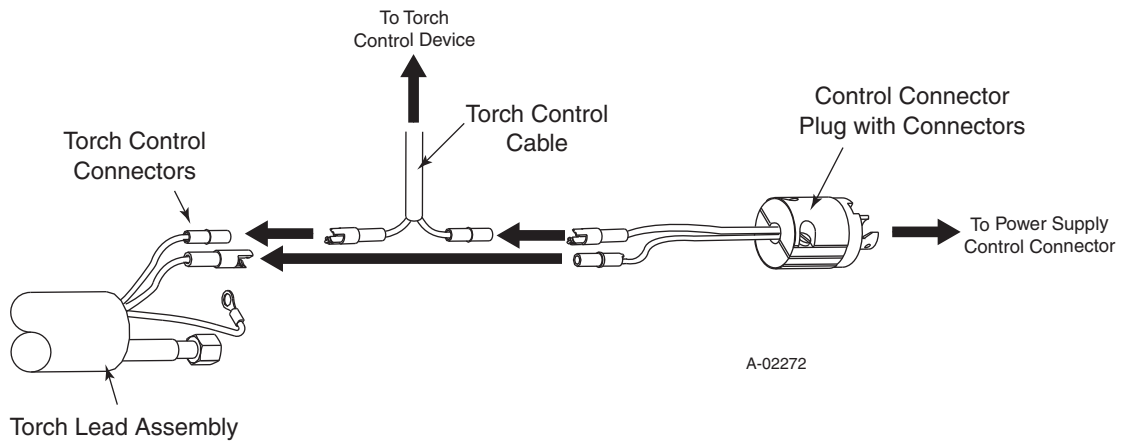

NOTE

Every effort has been made to provide complete and accurate information in this manual. However, the publisher does not assume and hereby disclaims any liability to any party for any loss or damage caused by errors or omissions in this manual, whether such errors result from negligence, accident or any other cause.

7-3436

RPT Adapter Kit

RPT Adapter Kit
Catalog # 7-3436

Control Plug
Connector



Pilot Connector



Pilot Connector (un-assembled)



RPT Adapter Kit Catalog # 7-3437

Installation Instructions

General Information

This Replacement Torch Adapter Kit is to be used to connect the Thermal Dynamics Plasma RPT Series Cutting Torch to the following equipment:

- MULTIQUIP MQ PCX50SS
- OTC D-5000 and D-7000
- P-TRON 75 and 100
- MRAT-70

Parts Supplied

The following parts are included in this kit:

- Control Connector Plug with Connectors (1 ea)
- Dummy Connector Plug (1 ea)

Installation

Install the Adapter Kit per the following procedure:

1. Turn OFF the power supply.
2. Disconnect the main input power to the power supply.
3. Remove the existing torch from the power supply, removing covers as required.
4. Install the Dummy Connector Plug provided into the Power Supply.
5. Connect the pilot wire (+) from the replacement torch to the Power Supply and tighten securely
6. Connect the Negative/Plasma Lead from the replacement torch to the Power Supply. Slide the protective boot over the lead connection.
7. Connect the Negative/Plasma Lead from the replacement torch to the Adapter Fitting.
8. Connect the Control Connector Plug (see NOTE), with two connectors, to the two mating connectors on the replacement torch leads.
9. Connect the Control Connector Plug to the Power Supply.
10. Reinstall any covers removed (see WARNING).
11. Install the proper torch consumables for the Power Supply amperage.
12. Reconnect main input power to the Power Supply and turn the unit ON.
13. Set air pressure to 60 - 70 psi (4.1 - 4.8 bar).
14. Test torch for proper operation.

NOTE

For Mechanized Systems refer to the Torch Control Cable Wiring Diagram on the last page of this Manual.

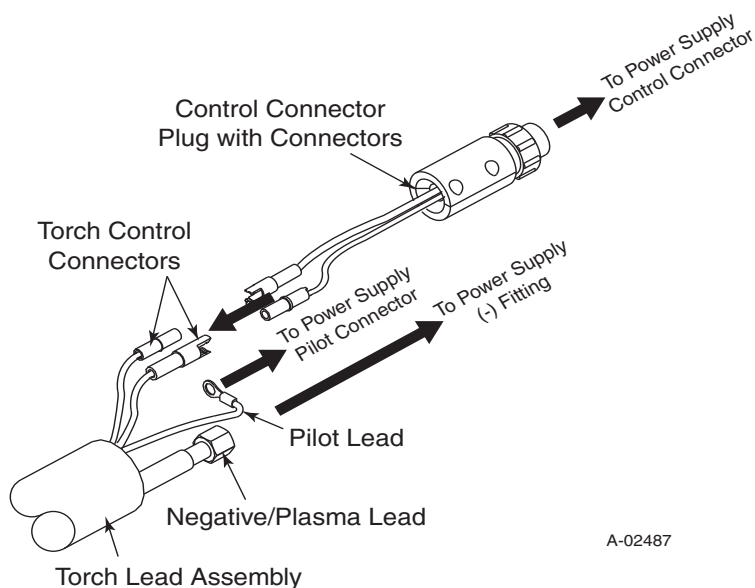

A-02487

 **WARNING**

Make sure that the Control Connector Plug wires DO NOT contact the Adapter Fitting after all leads are connected.

Torch Control Cable Wiring Diagram For Mechanized Systems

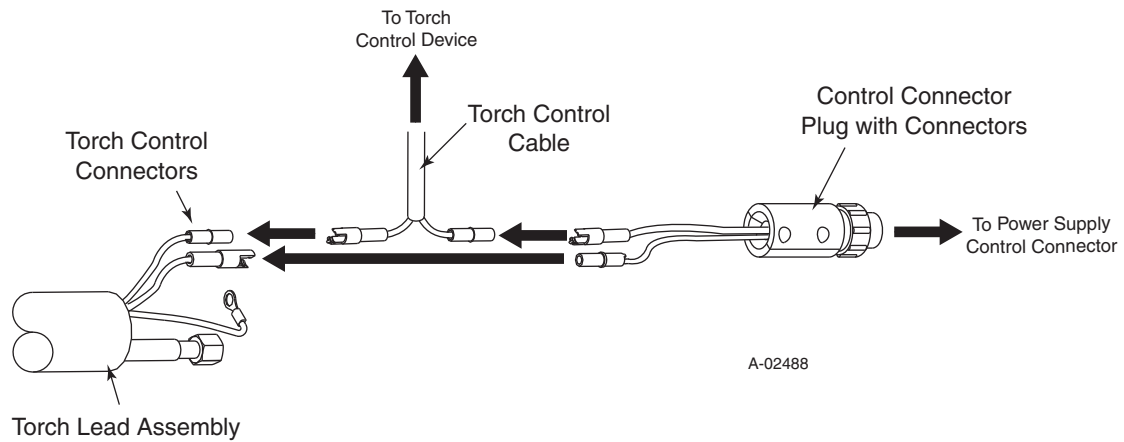

NOTE

Every effort has been made to provide complete and accurate information in this manual. However, the publisher does not assume and hereby disclaims any liability to any party for any loss or damage caused by errors or omissions in this manual, whether such errors result from negligence, accident or any other cause.

7-3437

RPT Adapter Kit



Control Plug
Connectors

RPT Adapter Kit Catalog # 7-3438

Installation Instructions

General Information

This Replacement Torch Adapter Kit is to be used to connect the Thermal Dynamics Plasma RPT Series Cutting Torch to the following equipment:

- CEBORA 50
- NU-TECSYS OMNICUT 375

Parts Supplied

The following parts are included in this kit:

- Control Connector Wires with Connectors (1 ea)
- Adapter Fitting (1 ea)

Installation

Install the Adapter Kit per the following procedure:

1. Turn OFF the power supply.
2. Disconnect the main input power to the power supply.
3. Remove the existing torch from the power supply, removing covers as required.
4. Place the Adapter Fitting provided into the Power Supply torch power cable fitting (-) and tighten securely.
5. Connect the pilot wire (+) from the replacement torch to the Power Supply and tighten securely
6. Connect the Negative/Plasma Lead from the replacement torch to the Adapter Fitting. Slide the protective boot over the lead connection.
7. Connect the Control Connector Wires (see NOTE), with two connectors, to the two mating connectors on the replacement torch leads.
8. Connect the fastons of the Control Connector Wires to the Power Supply.
9. Reinstall any covers removed (see WARNING).
10. Install the proper torch consumables for the Power Supply amperage.
11. Reconnect main input power to the Power Supply and turn the unit ON.
12. Set air pressure to 60 - 70 psi (4.1 - 4.8 bar).
13. Test torch for proper operation.

NOTE

For Mechanized Systems refer to the Torch Control Cable Wiring Diagram on the last page of this Manual.

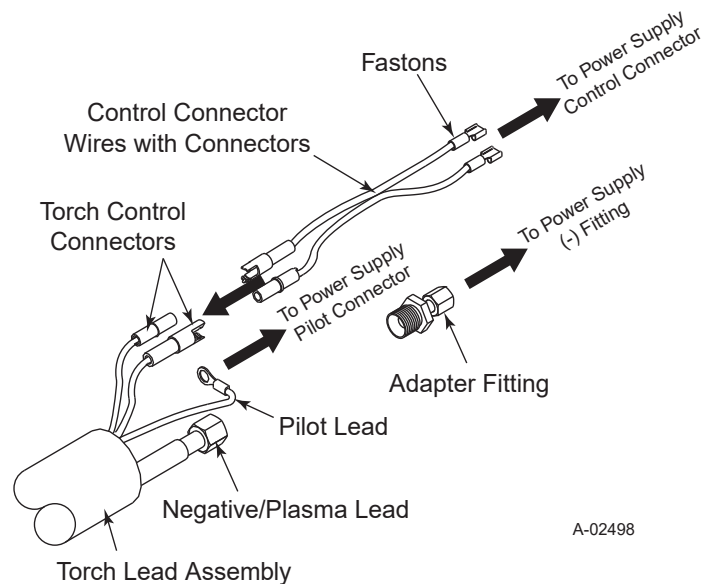

A-02498

⚡ WARNING

Make sure that the Control Connector Wires DO NOT contact the Adapter Fitting after all leads are connected.

Torch Control Cable Wiring Diagram For Mechanized Systems

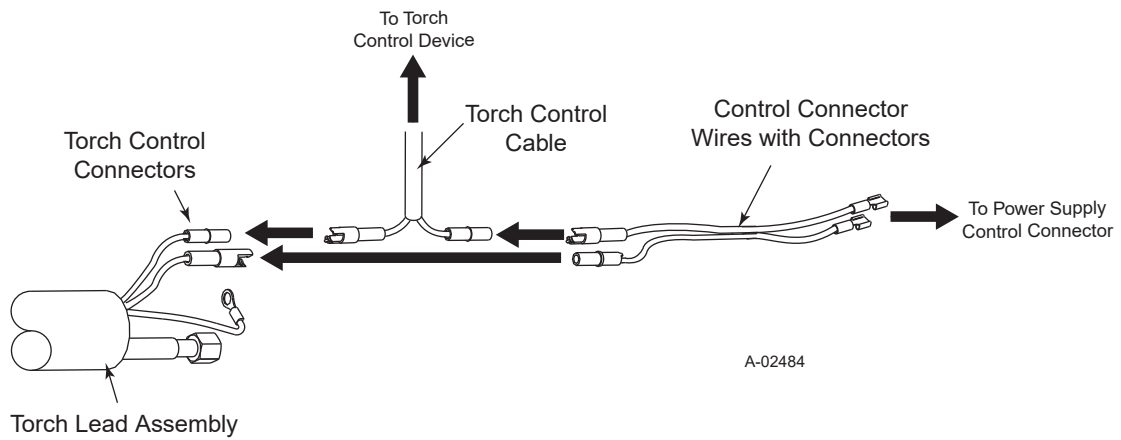

NOTE

Every effort has been made to provide complete and accurate information in this manual. However, the publisher does not assume and hereby disclaims any liability to any party for any loss or damage caused by errors or omissions in this manual, whether such errors result from negligence, accident or any other cause.

7-3438

RPT Adapter Kit



RPT Adapter Kit Catalog # 7-3439

Installation Instructions

General Information

This Replacement Torch Adapter Kit is to be used to connect the Thermal Dynamics Plasma RPT Series Cutting Torch to the following equipment:

HARRIS System 50, 65 and 100

Parts Supplied

The following parts are included in this kit:

- Control Connector Wires with Connectors (1 ea)
- Tie-Wrap (1 ea)

Installation

Install the Adapter Kit per the following procedure:

1. Turn OFF the power supply.
2. Disconnect the main input power to the power supply.
3. Remove the existing torch from the power supply, removing covers as required.
4. Connect the pilot wire (+) from the replacement torch to the Power Supply and tighten securely
5. Connect the Negative/Plasma Lead from the replacement torch to the Power Supply. Slide the protective boot over the lead connection.
6. Connect the Control Connector Wires (see NOTE), with two connectors, to the two mating connectors on the replacement torch leads.
7. Connect the fastons of the Control Connector Wires to the Power Supply.
8. Cover the connections with the original rubber boot and secure with the supplied tie-wrap.
9. Reinstall any covers removed (see WARNING).
10. Install the proper torch consumables for the Power Supply amperage.
11. Reconnect main input power to the Power Supply and turn the unit ON.
12. Set air pressure to 60 - 70 psi (4.1 - 4.8 bar).
13. Test torch for proper operation.

NOTE
 For Mechanized Systems refer to the Torch Control Cable Wiring Diagram on the last page of this Manual.

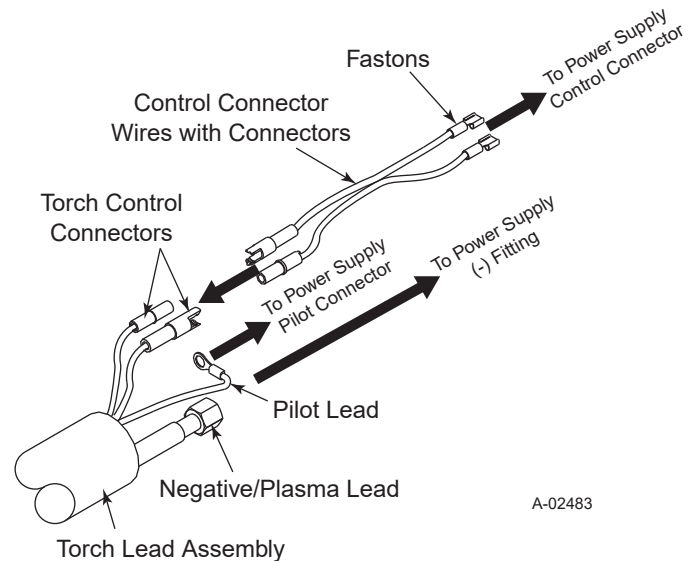

A-02483

WARNING
 Make sure that the Control Connector Wires DO NOT contact the Negative/Plasma Lead after all leads are connected.

Torch Control Cable Wiring Diagram For Mechanized Systems

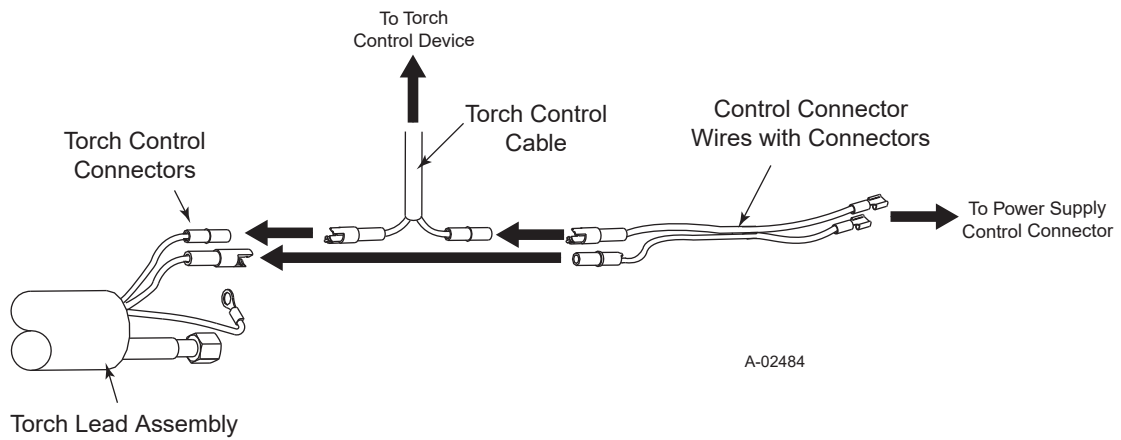

NOTE

Every effort has been made to provide complete and accurate information in this manual. However, the publisher does not assume and hereby disclaims any liability to any party for any loss or damage caused by errors or omissions in this manual, whether such errors result from negligence, accident or any other cause.

7-3439

RPT Adapter Kit



RPT Adapter Kit Catalog # 7-3440

Installation Instructions

General Information

This Replacement Torch Adapter Kit is to be used to connect the Thermal Dynamics Plasma RPT Series Cutting Torch to the following equipment:

HOBART FAB SHOP

Parts Supplied

The following parts are included in this kit:

- Control Connector Wires with Connectors (1 ea)
- Adapter Fitting (1 ea)

Installation

Install the Adapter Kit per the following procedure:

1. Turn OFF the power supply.
2. Disconnect the main input power to the power supply.
3. Remove the existing torch from the power supply, removing covers as required.
4. Place the Adapter Fitting provided into the Power Supply torch power cable fitting (-) and tighten securely.
5. Connect the pilot wire (+) from the replacement torch to the Power Supply and tighten securely.
6. Connect the Negative/Plasma Lead from the replacement torch to the Adapter Fitting. Slide the protective boot over the lead connection.
7. Connect the Control Connector Wires (see NOTE), with two connectors, to the two mating connectors on the replacement torch leads.
8. Connect the fastons of the Control Connector Wires to the Power Supply. The connectors are for the old safety circuit. The replacement Torch has the trigger and safety circuit wired in series.
9. Reinstall any covers removed (see WARNING).
10. Install the proper torch consumables for the Power Supply amperage.
11. Reconnect main input power to the Power Supply and turn the unit ON.
12. Set air pressure to 60 - 70 psi (4.1 - 4.8 bar).
13. Test torch for proper operation.

NOTE

For Mechanized Systems refer to the Torch Control Cable Wiring Diagram on the last page of this Manual.

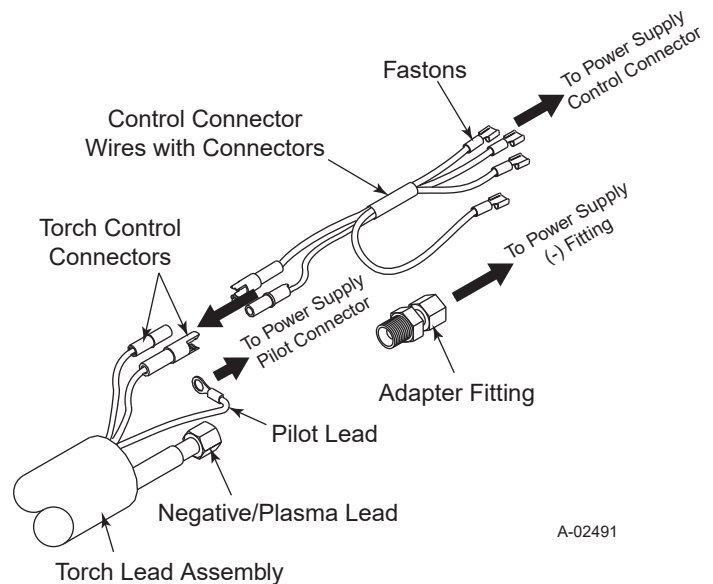

A-02491



WARNING

Make sure that the Control Connector Wires DO NOT contact the Adapter Fitting after all leads are connected.

Torch Control Cable Wiring Diagram For Mechanized Systems

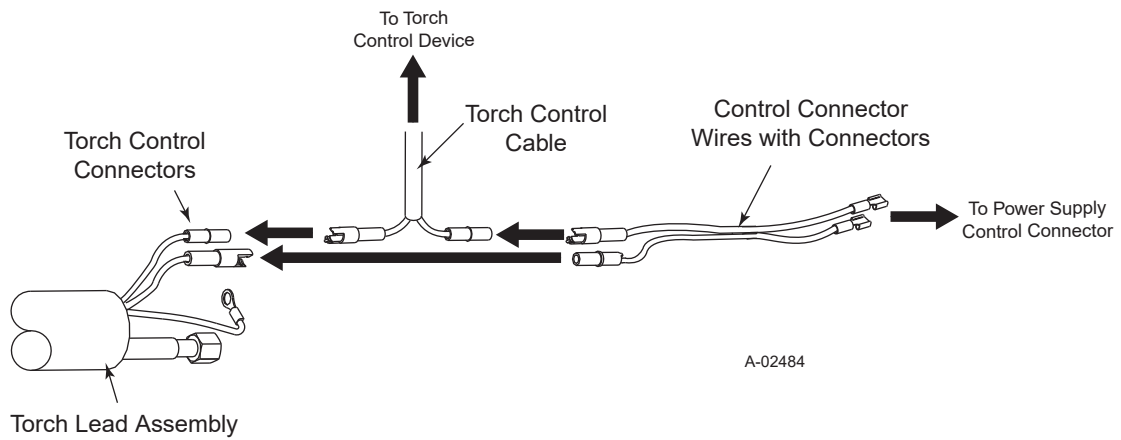

NOTE

Every effort has been made to provide complete and accurate information in this manual. However, the publisher does not assume and hereby disclaims any liability to any party for any loss or damage caused by errors or omissions in this manual, whether such errors result from negligence, accident or any other cause.

7-3440

RPT Adapter Kit



RPT Adapter Kit Catalog # 7-3441

Installation Instructions

General Information

This Replacement Torch Adapter Kit is to be used to connect the Thermal Dynamics Plasma RPT Series Cutting Torch to the following equipment:

NU-TECSYS PCA-30/60 and 65

Parts Supplied

The following parts are included in this kit:

- Control Connector Wires with Connectors (1 ea)
- Adapter Fitting (1 ea)

Installation

Install the Adapter Kit per the following procedure:

1. Turn OFF the power supply.
2. Disconnect the main input power to the power supply.
3. Remove the existing torch from the power supply, removing covers as required.
4. Place the Adapter Fitting provided into the Power Supply torch power cable fitting (-) and tighten securely.
5. Connect the pilot wire (+) from the replacement torch to the Power Supply and tighten securely
6. Connect the Negative/Plasma Lead from the replacement torch to the Adapter Fitting. Slide the protective boot over the lead connection.
7. Connect the Control Connector Wires (see NOTE), with two connectors, to the two mating connectors on the replacement torch leads.
8. Connect the fastons of the Control Connector Wires to the Power Supply.
9. Reinstall any covers removed (see WARNING).
10. Install the proper torch consumables for the Power Supply amperage.
11. Reconnect main input power to the Power Supply and turn the unit ON.
12. Set air pressure to 60 - 70 psi (4.1 - 4.8 bar).
13. Test torch for proper operation.

NOTE

For Mechanized Systems refer to the Torch Control Cable Wiring Diagram on the last page of this Manual.

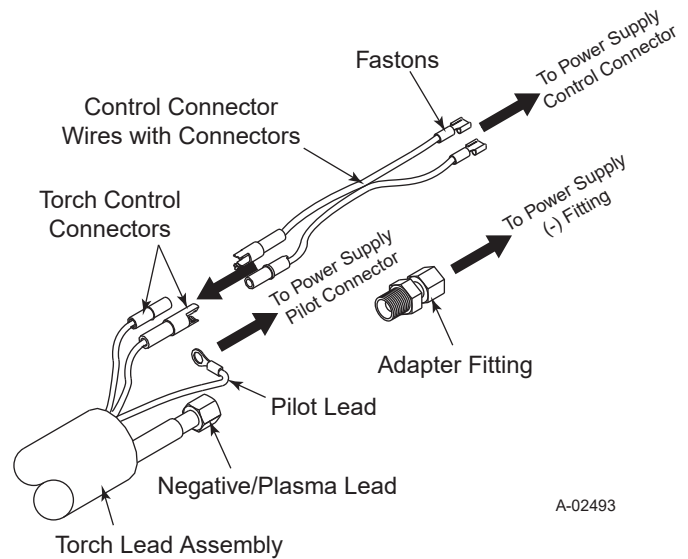

A-02493



WARNING

Make sure that the Control Connector Wires DO NOT contact the Adapter Fitting after all leads are connected.

Torch Control Cable Wiring Diagram For Mechanized Systems

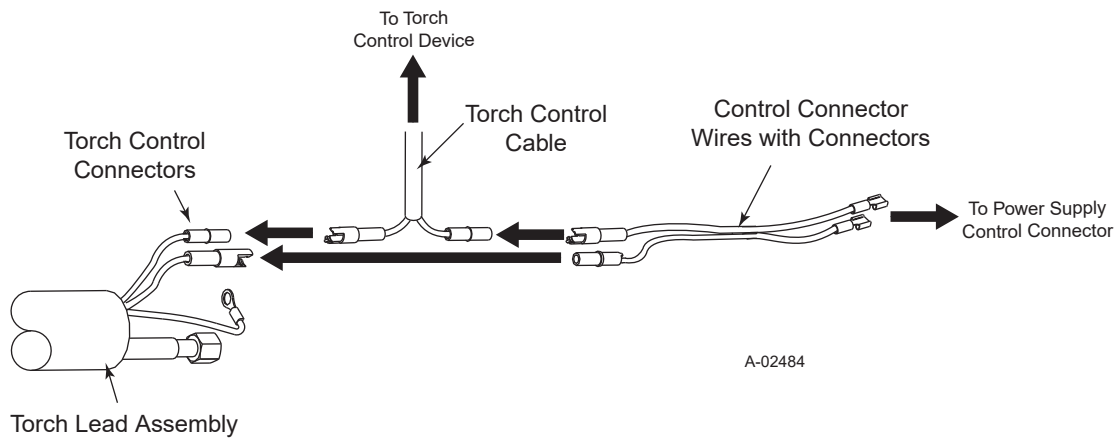

NOTE

Every effort has been made to provide complete and accurate information in this manual. However, the publisher does not assume and hereby disclaims any liability to any party for any loss or damage caused by errors or omissions in this manual, whether such errors result from negligence, accident or any other cause.

7-3441

RPT Adapter Kit



Manual 0-2767

RPT Adapter Kit Catalog # 7-3441

Installation Instructions

Negative Adaptor

Control Plug
Connector

RPT Adapter Kit Catalog # 7-3442

Installation Instructions

General Information

This Replacement Torch Adapter Kit is to be used to connect the Thermal Dynamics Plasma RPT Series Cutting Torch to the following equipment:

SMITH SPC-30, 20-50 and 40-80

Parts Supplied

The following parts are included in this kit:

- Control Connector Plug with Connectors (1 ea)
- Adapter Fitting (1 ea)
- Pilot Adapter Fitting (1 ea)

Installation

Install the Adapter Kit per the following procedure:

1. Turn OFF the power supply.
2. Disconnect the main input power to the power supply.
3. Remove the existing torch from the power supply, removing covers as required.
4. Place the Adapter Fitting provided into the Power Supply torch power cable fitting (-) and tighten securely.
5. Connect the pilot wire (+) from the replacement torch to the Power Supply Pilot Adapter Fitting with the screw provided and tighten securely
6. Plug the Pilot Adapter Fitting into the Power Supply Pilot Connection.
7. Connect the Negative/Plasma Lead from the replacement torch to the Adapter Fitting. Slide the protective boot over the lead connection.
8. Connect the Control Connector Plug (see NOTE), with two connectors, to the two mating connectors on the replacement torch leads.
9. Connect the Control Connector Plug to the Power Supply.
10. Reinstall any covers removed (see WARNING).
11. Install the proper torch consumables for the Power Supply amperage.
12. Reconnect main input power to the Power Supply and turn the unit ON.
13. Set air pressure to 60 - 70 psi (4.1 - 4.8 bar).
14. Test torch for proper operation.

NOTE
<i>For Mechanized Systems refer to the Torch Control Cable Wiring Diagram on the last page of this Manual.</i>

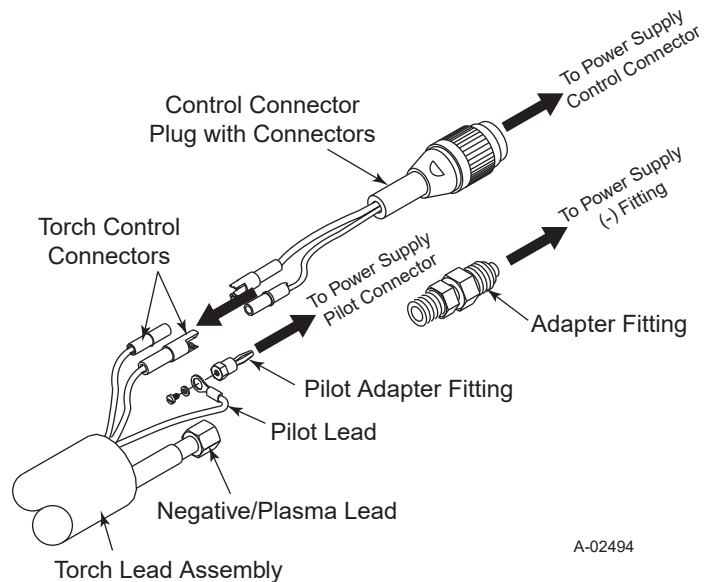

A-02494

 WARNING
<p>Make sure that the Control Connector Plug wires DO NOT contact the Adapter Fitting after all leads are connected.</p>

Torch Control Cable Wiring Diagram For Mechanized Systems

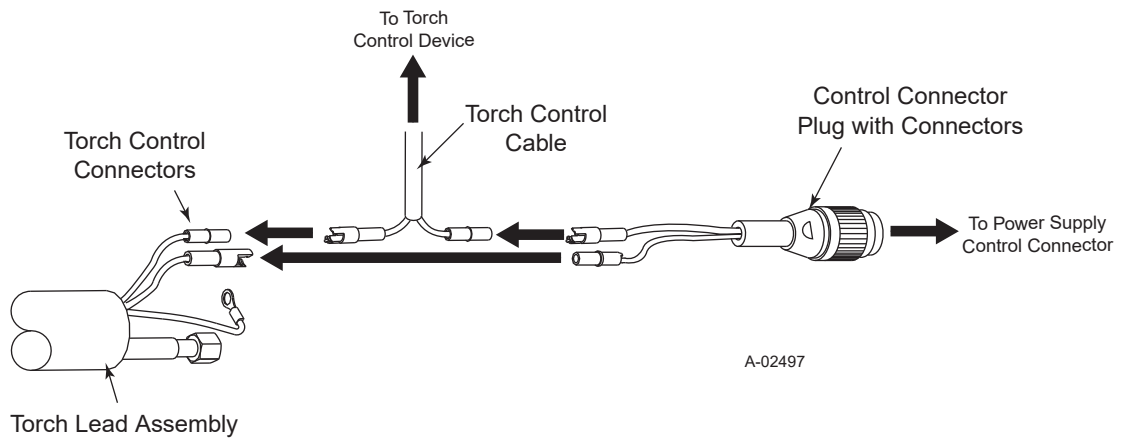

NOTE

Every effort has been made to provide complete and accurate information in this manual. However, the publisher does not assume and hereby disclaims any liability to any party for any loss or damage caused by errors or omissions in this manual, whether such errors result from negligence, accident or any other cause.

7-3442

RPT Adapter Kit



RPT Adapter Kit Catalog # 7-3443

Installation Instructions

General Information

This Replacement Torch Adapter Kit is to be used to connect the Thermal Dynamics Plasma RPT Series Cutting Torch to the following equipment:

- Thermal Dynamics PAK-4Xi, 6Xi, 2XT-220 and DynaPak 110
- Thermal Dynamics Pak Master 25 and 38XL
- Thermal Dynamics EconoPak 25
- Thermal Dynamics Drag-Gun 38

Parts Supplied

The following parts are included in this kit:

- Control Connector Wires with Connectors -
 - 8" Long for PAK-4Xi, 6Xi, 2XT-220 and DynaPak 110 (1 ea)
 - 3" Long for Pak Master 25 & 38XL, EconoPak 25 and Drag-Gun 38 (1 ea)
- Pilot Return Adapter (90° Faston Terminal) for Pak Master 25 & 38XL, EconoPak 25 and Drag-Gun 38 (1 ea)
- Adapter Fitting (1 ea)
- Panel Bushing (1 ea)

Installation

Install the Adapter Kit per the following procedure:

1. Turn OFF the power supply.
2. Disconnect the main input power to the power supply.
3. Remove the existing torch from the power supply, removing covers as required.
4. Place the Panel Bushing provided into the Torch Leads Access hole in the unit.
5. Place the Adapter Fitting provided into the Power Supply torch power cable fitting (-) and tighten securely.

6. Connect the pilot wire (+) from the replacement torch to the Power Supply per one of the following procedures.

For PAK-4Xi, 6Xi, 2XT-220 and DynaPak 110:

Connect the pilot wire (+) from the replacement torch to the Power Supply and tighten securely.

For Pak Master 25 & 38XL, EconoPak 25 and Drag-Gun 38:

Cut off the ring terminal from the pilot lead of the replacement torch. Strip the wire insulation 9/32". Crimp the 1/4" insulated 90° faston terminal onto the pilot lead. Connect the faston to the pilot terminal on the Power Supply.

7. Connect the Negative/Plasma Lead from the replacement torch to the Adapter Fitting. Slide the protective boot over the lead connection.

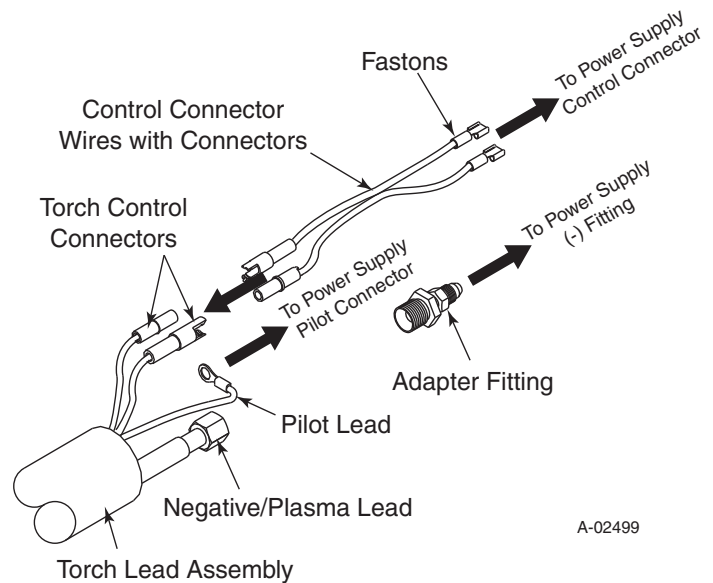

A-02499

8. Connect the Control Connector Wire (see NOTE) to the two mating connectors on the replacement torch leads per one of the following procedures:

For PAK-4Xi, 6Xi, 2XT-220 and DynaPak 110:

Connect the Control Connector Wires (8" long), with two connectors, to the two mating connectors on the replacement torch leads.

For Pak Master 25 & 38XL, EconoPak 25 and Drag-gun 38:

Connect the Short Control Connector Wire (3" long), with two connectors, to the two mating connectors on the replacement torch leads.

NOTE

For Mechanized Systems refer to the Torch Control Cable Wiring Diagram in the Manual supplied with the RPT Torch.

9. Connect the fastons of the Control Connector Wires to the Power Supply.
10. Reinstall any covers removed (see WARNING).
11. Install the proper torch consumables for the Power Supply amperage.
12. Reconnect main input power to the Power Supply and turn the unit ON.
13. Set air pressure to 60 - 70 psi (4.1 - 4.8 bar).
14. Test torch for proper operation.



WARNING

Make sure that the Control Connector Wires DO NOT contact the Adapter Fitting after all leads are connected.

NOTE

Every effort has been made to provide complete and accurate information in this manual. However, the publisher does not assume and hereby disclaims any liability to any party for any loss or damage caused by errors or omissions in this manual, whether such errors result from negligence, accident or any other cause.

7-3443

RPT Adapter Kit



RPT Adapter Kit Catalog # 7-3444

Installation Instructions

General Information

This Replacement Torch Adapter Kit is to be used to connect the Thermal Dynamics Plasma RPT Series Cutting Torch to the following equipment:

- Thermal Dynamics PAK 5

Parts Supplied

The following parts are included in this kit:

- Control Connector Plug with Connectors (1 ea)
- Adapter Fitting (1 ea)
- Secondary Gas Plug/Pilot Adapter Fitting (1 ea)

Installation

Install the Adapter Kit per the following procedure:

1. Turn OFF the power supply.
2. Disconnect the main input power to the power supply.
3. Remove the existing torch from the power supply, removing covers as required.
4. Place the Adapter Fitting provided into the Power Supply torch power cable fitting (-) and tighten securely.
5. Install the supplied Secondary Gas Plug/Pilot Adapter Fitting onto the Power Supply.
6. Connect the pilot wire (+) from the replacement torch to the Power Supply Secondary Gas Plug/Pilot Adapter Fitting with the bolt and washer provided and tighten securely.
7. Connect the Negative/Plasma Lead from the replacement torch to the Power Supply. Slide the protective boot over the lead connection.
8. Connect the Control Connector Plug (see NOTE), with two connectors, to the two mating connectors on the replacement torch leads.
9. Connect the Control Connector Plug to the Power Supply.
10. Reinstall any covers removed (see WARNING).
11. Install the proper torch consumables for the Power Supply amperage.
12. Reconnect main input power to the Power Supply and turn the unit ON. Secondary gas pressure must be supplied to the Power Supply to activate the secondary gas circuit.
13. Set air pressure to 60 - 70 psi (4.1 - 4.8 bar).
14. Test torch for proper operation.

NOTE
For Mechanized Systems refer to the Torch Control Cable Wiring Diagrams in the Manual supplied with the RPT Torch.

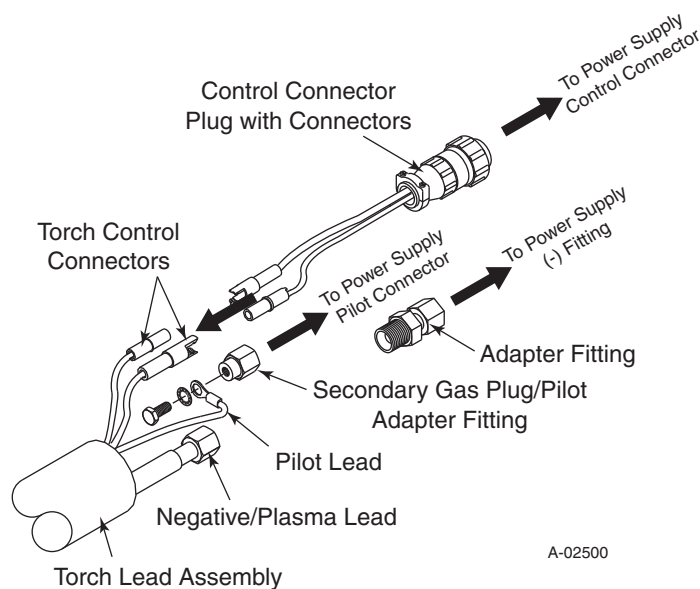

A-02500

 WARNING
<p>Make sure that the Control Connector Plug wires DO NOT contact the Adapter Fitting after all leads are connected.</p>

NOTE

Every effort has been made to provide complete and accurate information in this manual. However, the publisher does not assume and hereby disclaims any liability to any party for any loss or damage caused by errors or omissions in this manual, whether such errors result from negligence, accident or any other cause.

7-3444

RPT Adapter Kit



General Information

This Replacement Torch Adapter Kit is to be used to connect the Thermal Dynamics Plasma RPT Series Cutting Torch to the following equipment:

- Thermal Dynamics Pak Master 50 with Smart Torch

Parts Supplied

The following parts are included in this kit:

- Signal Pin Connector with Wires and Connectors (1 ea)
- Pilot Adapter Fitting (1 ea)
- Rubber Insulator (1 ea)
- Tie-Wrap (1 ea)

Installation

Install the Adapter Kit per the following procedure:

A. Disassembling Old Quick Disconnect

To disassemble the quick disconnect connector, use the following procedure (see Warning):

1. Disconnect the torch leads from the power supply.
2. Turn the outer retaining nut until one of the three set screws in the inner retaining ring is visible through one of the slots in the nut.
3. Partially loosen each of the set screws which secure the inner retaining ring and boot onto the quick disconnect body. If the set screws are turned too far out, the outer retaining nut will not turn properly.

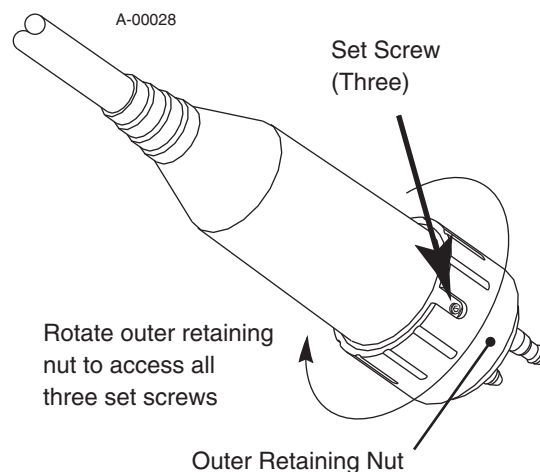

NOTE

For Mechanized Systems refer to the Torch Control Cable Wiring Diagram on the last page of this Manual.



WARNING

Disconnect primary power to the system before disassembling the torch or torch leads.

4. Pull the protective boot and inner retaining ring from the quick disconnect body.

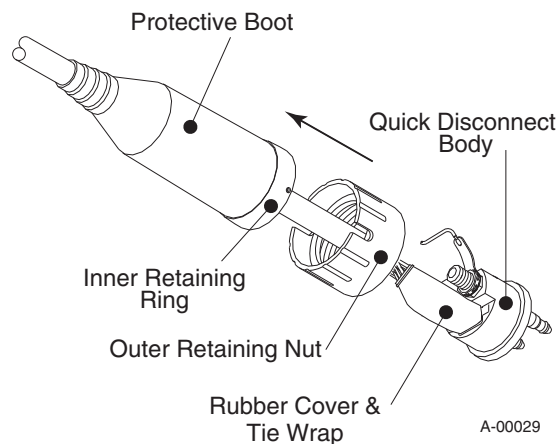

Disassembly Of Connector

5. Slide the protective boot and inner retaining ring back over the torch leads to expose the leads connections.
6. Slide the outer retaining nut back over the leads.
7. Using a pair of needle nose pliers remove the two white tabs on each side of the signal connector. These tabs hold the connector tightly in place to prevent it from moving.

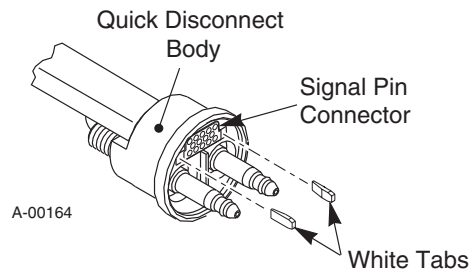

Removing White Tabs

8. Using a small screwdriver, gently push in the tabs on the front of the Signal Pin Connector. Carefully push the connector out through the back of the quick disconnect body.

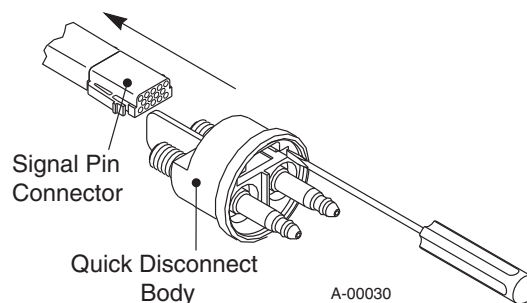

Removing Signal Pin Connector

9. Cut all the wires connected to the Signal Pin Connector. The rubber boot cannot fit over the Signal Pin Connector.
10. Disconnect the negative/plasma and pilot lead fittings.

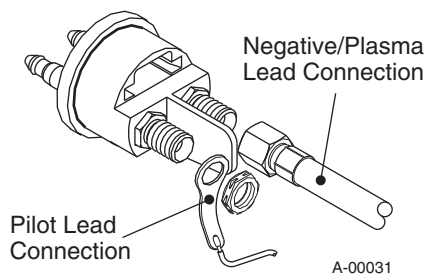

Disconnecting Leads

11. Remove the protective boot, inner retaining ring and outer retaining nut from the old leads.
12. Discard the old leads and Signal Pin Connector.

B. Reassembling New Quick Disconnect

1. Slide the protective boot, inner retaining ring and outer retaining nut from the old torch onto the replacement torch leads.
2. Slide the supplied rubber insulator over the control connector wires on the replacement torch.
3. Install the Pilot Adapter Fitting (left-hand threads) onto the pilot fitting of the Quick Disconnect Body and tighten securely.
4. Connect the pilot wire (+) from the replacement torch to the Pilot Adapter Fitting and tighten securely with bolt and washer provided.
5. Connect the Negative/Plasma Lead from the replacement torch to the fitting on the Quick Disconnect Body and tighten securely.
6. Locate the replacement Signal Pin Connector and insert the free end of the wire from hole #12 into the following location:
 - Using RPT-28 Torch for 35 amp systems use hole #11

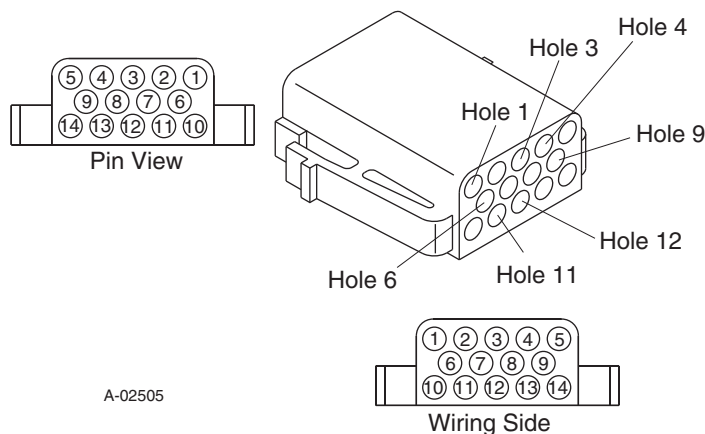
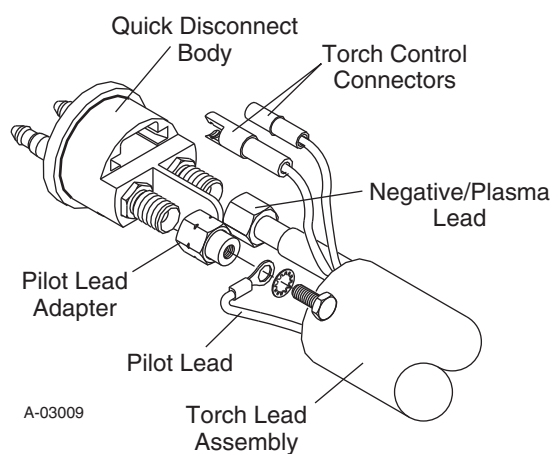

Signal Connector Wiring

7. Insert the Signal Pin Connector in the quick disconnect body and install the two white locking tabs on both sides. The bevel must be towards the signal connector.

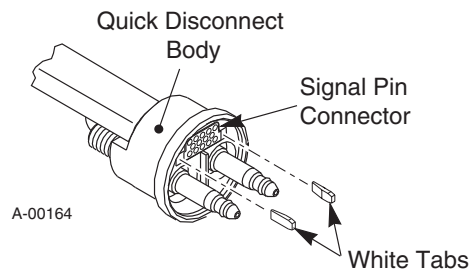

Installing The White Locking Tabs

8. On the Signal Pin Connector connect the wires from hole #4 and hole #3 to the two mating connectors on the replacement torch leads.
9. Slide the rubber insulator down over the control wires and the exposed end of the Signal Pin Connector. Secure in place with the supplied Tie-Wrap.
10. Slide the outer retaining nut, boot, and inner retaining ring down onto the quick disconnect body.
11. Tighten the three set screws to secure the inner retaining ring onto the quick disconnect body.
12. Install the proper torch consumables for the Power Supply amperage.
13. Connect the torch to the Power Supply.
14. Reconnect main input power to the Power Supply and turn the unit ON.
15. Set air pressure to 60 - 70 psi (4.1 - 4.8 bar).
16. Test torch for proper operation.

Torch Control Cable Wiring Diagram For Mechanized Systems

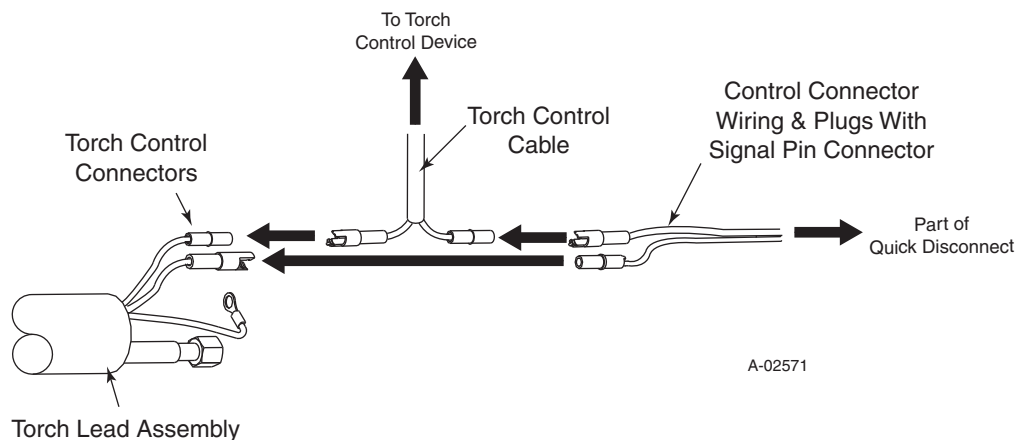

NOTE

Every effort has been made to provide complete and accurate information in this manual. However, the publisher does not assume and hereby disclaims any liability to any party for any loss or damage caused by errors or omissions in this manual, whether such errors result from negligence, accident or any other cause.

7-3445

RPT Adapter Kit

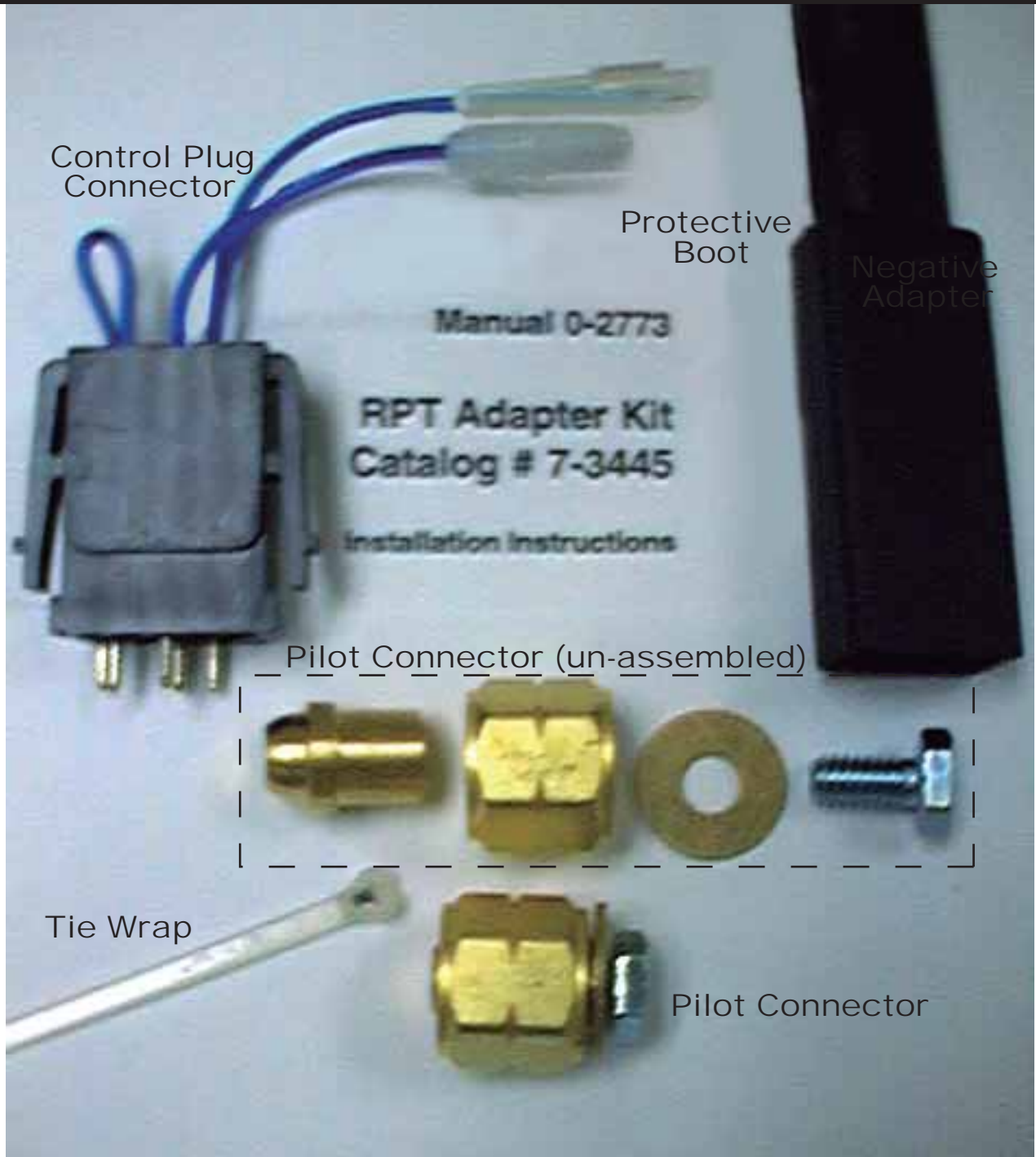

RPT Adapter Kit Catalog # 7-3446

Installation Instructions

General Information

This Replacement Torch Adapter Kit is to be used to connect the Thermal Dynamics Plasma RPT Series Cutting Torch to the following equipment:

Thermal Dynamics PAK 3XR, 5XR, 5XT, 6XR, 7XR, 625XR and 750XR

Parts Supplied

The following parts are included in this kit:

- Control Connector Plug with Connectors (1 ea)
- Secondary Gas Output Plug (1 ea)
- Adapter Fitting (Flow) With Orifice (1 ea)

Installation

Install the Adapter Kit per the following procedure:

1. Turn OFF the power supply.
2. Disconnect the main input power to the power supply.
3. Remove the existing torch from the power supply, removing covers as required.
4. Place the Adapter Fitting (Flow) provided into the Power Supply torch power cable fitting (-) and tighten securely.
5. Connect the pilot wire (+) from the replacement torch to the Power Supply and tighten securely.
6. Connect the Negative/Plasma Lead from the replacement torch to the Power Supply. Slide the protective boot over the lead connection.
7. Connect the Control Connector Plug (see NOTE), with two connectors, to the two mating connectors on the replacement torch leads.
8. Connect the Control Connector Plug to the Power Supply.
9. For dual gas machines, install the supplied left-handed Secondary Gas Output Plug to block off the secondary gas output.
10. Adjust the HF Spark Gap setting inside the Power Supply use the following procedure:
 - a. Remove the Right Side Panel from the Power Supply.
 - b. Locate the Spark Gap Assembly on the Upper Equipment Panel.
 - c. Using an allen wrench loosen the set screw on the top of the outside brass block until the electrode can be moved.
 - d. Adjust the electrode for the proper 0.030" (0.76 mm) gap between the two electrodes.
 - e. Tighten the set screw to secure the electrode.
 - f. Re-install the Power Supply Side Panel.

NOTE
<i>For Mechanized Systems refer to the Torch Control Cable Wiring Diagrams in the Manual supplied with the RPT Torch.</i>

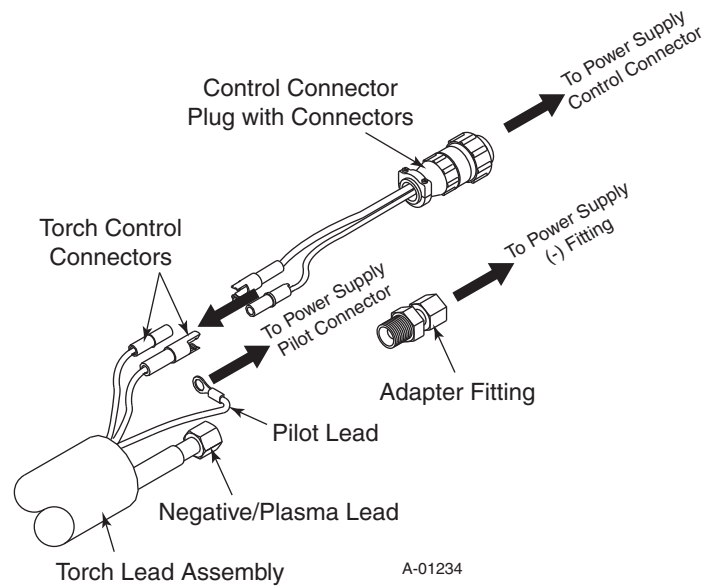

11. Reinstall any covers removed (see WARNING).
12. Install the proper torch consumables for the Power Supply amperage.
13. Reconnect main input power to the Power Supply and turn the unit ON.
14. Set air pressure to 60 - 70 psi (4.1 - 4.8 bar).
15. Test torch for proper operation.



WARNING

Make sure that the Control Connector Plug wires **DO NOT** contact the Adapter Fitting after all leads are connected.

NOTE

Every effort has been made to provide complete and accurate information in this manual. However, the publisher does not assume and hereby disclaims any liability to any party for any loss or damage caused by errors or omissions in this manual, whether such errors result from negligence, accident or any other cause.

7-3446

RPT Adapter Kit

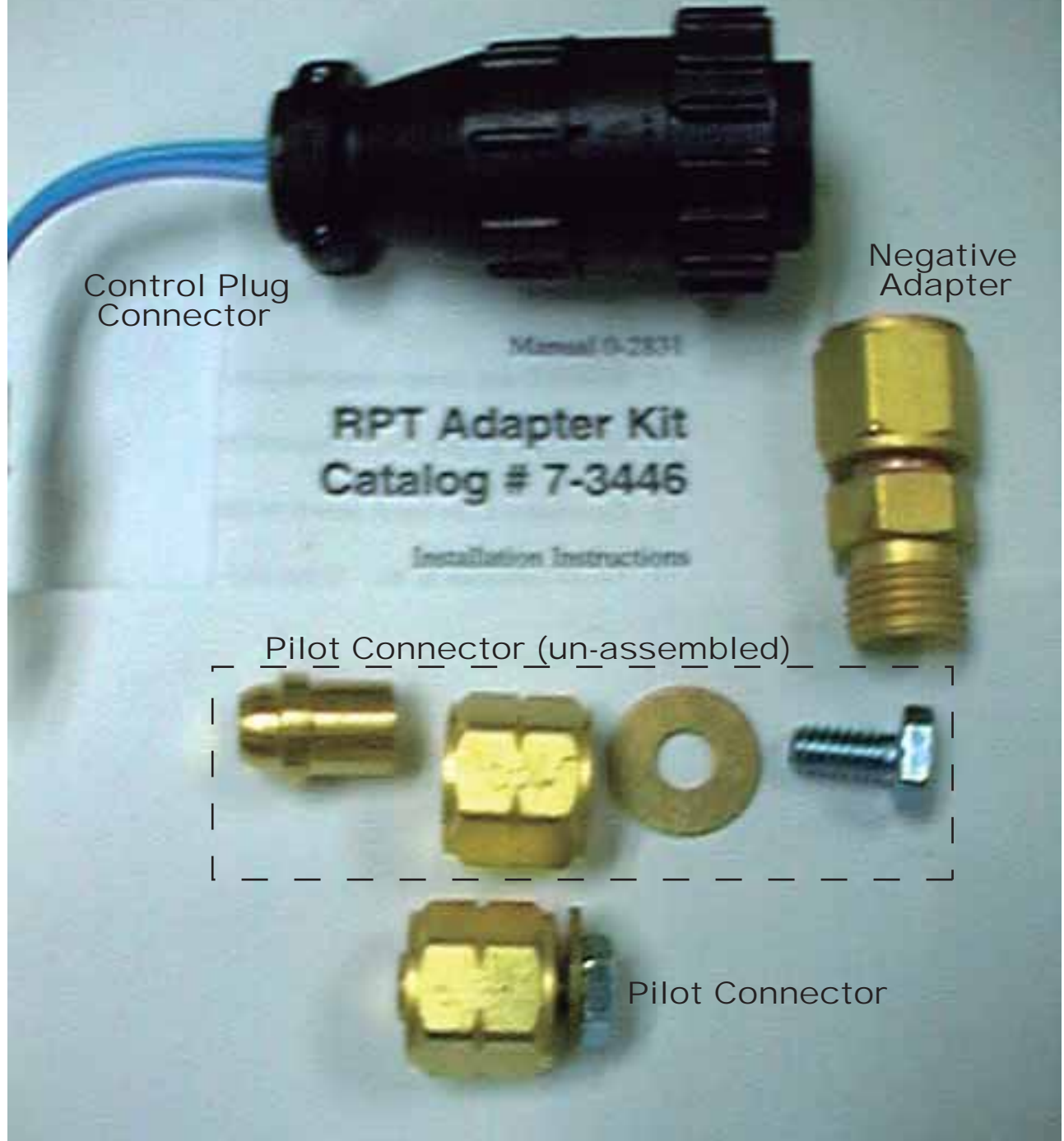

General Information

This Replacement Torch Adapter Kit is to be used to connect the Thermal Dynamics Plasma RPT Series Cutting Torch to the following equipment:

- Thermal Dynamics PakMaster XL Series, PakMaster XL Plus Series and CutMaster 80XL

Parts Supplied

The following parts are included in this kit:

- Control Connector Plug with Connectors - 1 ea
- Strain Relief - 1 ea

Installation

Install the Adapter Kit per the following procedure:

1. Turn OFF the power supply.
2. Disconnect the main input power to the power supply.
3. Remove the existing torch from the power supply, removing covers as required.
4. The Strain Relief included in this kit is a device to prevent damage to the Torch Leads resulting from a direct through panel exposure. All plasma cutting systems may not be equipped to utilize this Strain Relief.

On units where the Strain Relief can be used, install as follows:

- a. Remove the retaining nut from the Strain Relief.
- b. Place the end of the Strain Relief into the hole in the unit.
- c. Secure the Strain Relief to the Power Supply with the retaining nut.
- d. Loosen the leads capture nut on the outside of the Strain Relief.
- e. Feed the torch lead ends through the Strain Relief and into the unit.
- f. Tighten the leads capture nut to secure the Strain Relief onto the Torch Leads.

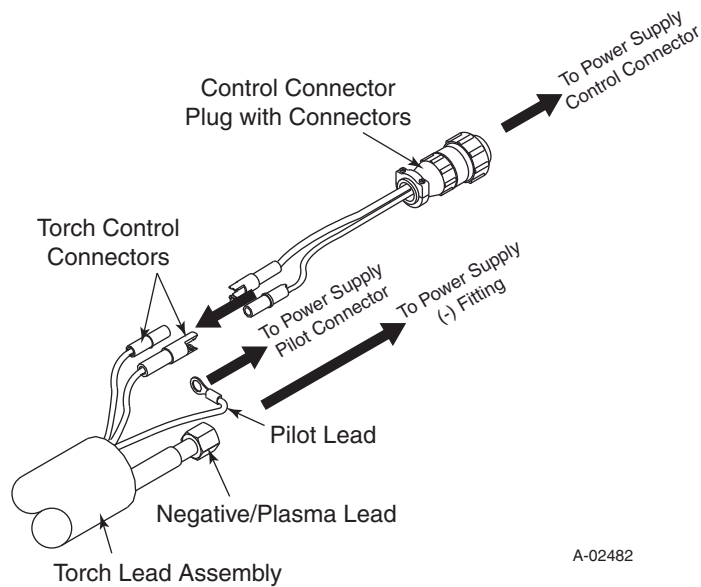

A-02482

5. Connect the pilot wire (+) from the replacement torch to the Power Supply and tighten securely.
6. Connect the Negative / Plasma Lead from the replacement torch to the Power Supply. Slide the protective boot over the lead connection.
7. Connect the Control Connector Plug, with two connectors, to the two mating connectors on the replacement torch leads.
8. Connect the Control Connector Plug to the Power Supply.
9. Reinstall any covers removed, see WARNING.
10. Install the proper torch consumables for the Power Supply amperage.
11. Reconnect input power and turn ON the unit.
12. Set proper gas pressure or flow.
13. Test torch for proper operation.

NOTE

For Mechanized Systems refer to the Torch Control Cable Wiring Diagrams in the Manual supplied with the RPT Torch.



WARNING

Make sure that the Control Connector Plug wires DO NOT contact the Adapter Fitting after all leads are connected.

NOTE

Every effort has been made to provide complete and accurate information in this manual. However, the publisher does not assume and hereby disclaims any liability to any party for any loss or damage caused by errors or omissions in this manual, whether such errors result from negligence, accident or any other cause.

7-3447

RPT Adapter Kit

Manual 0-2828

RPT Adapter Kit
Catalog # 7-3447

Installation Instructions

Control Plug
Connector



RPT Adapter Kit Catalog # 7-3449

Installation Instructions

General Information

This Replacement Torch Adapter Kit is to be used to connect the Thermal Dynamics Plasma RPT Series Cutting Torch to the following equipment:

Thermal Dynamics EconoPak 50

Parts Supplied

The following parts are included in this kit:

- Control Connector Wires with Connectors (1 ea)
- Pilot Return Adapter with Insulation Sleeving (1 ea)
- Adapter Fitting (1 ea)
- Panel Bushing (1 ea)
- Tie-Wrap (2 ea)

Installation

Install the Adapter Kit per the following procedure:

1. Turn OFF the power supply.
2. Disconnect the main input power to the power supply.
3. Remove the existing torch from the power supply, removing covers as required. Note the location of the two tie-wraps used to secure the control and pilot lead wiring.
4. Place the Panel Bushing provided into the Torch Leads Access hole in the unit.
5. Place the Adapter Fitting provided into the Power Supply torch power cable fitting (-) and tighten securely.
6. Connect the pilot wire (+) from the replacement torch to the Power Supply per the following procedure:
 - a. Cut off the ring terminal from the pilot lead of the replacement torch.
 - b. Strip the pilot lead wire insulation 9/32 inch.
 - c. Crimp the Pilot Return Adapter onto the pilot lead.
 - d. Pull the Pilot Return Insulation Sleeving over the butt (in-line) splice.
 - e. Connect the end of the Pilot Return Adapter to the pilot terminal on the Power Supply.
7. Connect the Negative/Plasma Lead from the replacement torch to the Adapter Fitting. Slide the protective boot over the lead connection.
8. Connect the Control Connector Wire (see NOTE) to the two mating connectors on the replacement torch leads to the two mating connectors on the replacement torch leads.

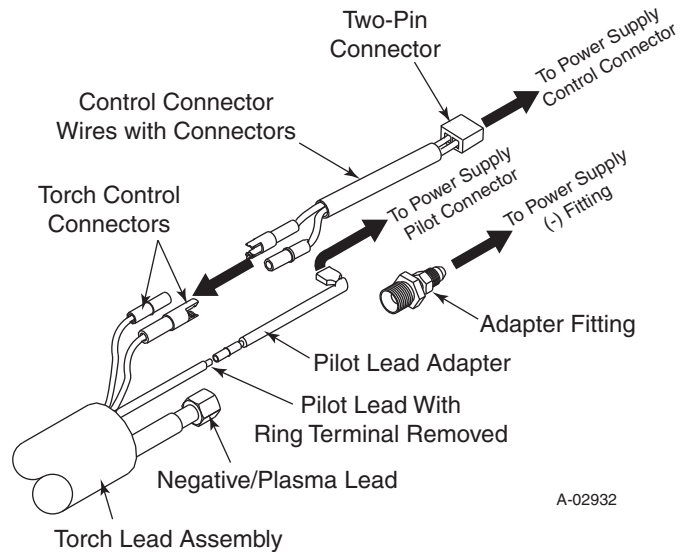

A-02932

NOTE

For Mechanized Systems refer to the Torch Control Cable Wiring Diagram in the Manual supplied with the RPT Torch.

9. Connect the fastons of the Control Connector Wires to the Power Supply. Install the two replacement tie-wraps in the same location as noted in Step 3 above to secure the control and pilot leads to the existing wiring.
10. Reinstall any covers removed (see WARNING).
11. Install the proper torch consumables for the Power Supply amperage.
12. Reconnect main input power to the Power Supply and turn the unit ON.
13. Set air pressure to 60 - 70 psi (4.1 - 4.8 bar).
14. Test torch for proper operation.

 WARNING
Make sure that the Control Connector Wires DO NOT contact the Adapter Fitting after all leads are connected.

NOTE

Every effort has been made to provide complete and accurate information in this manual. However, the publisher does not assume and hereby disclaims any liability to any party for any loss or damage caused by errors or omissions in this manual, whether such errors result from negligence, accident or any other cause.

7-3449

RPT Adapter Kit

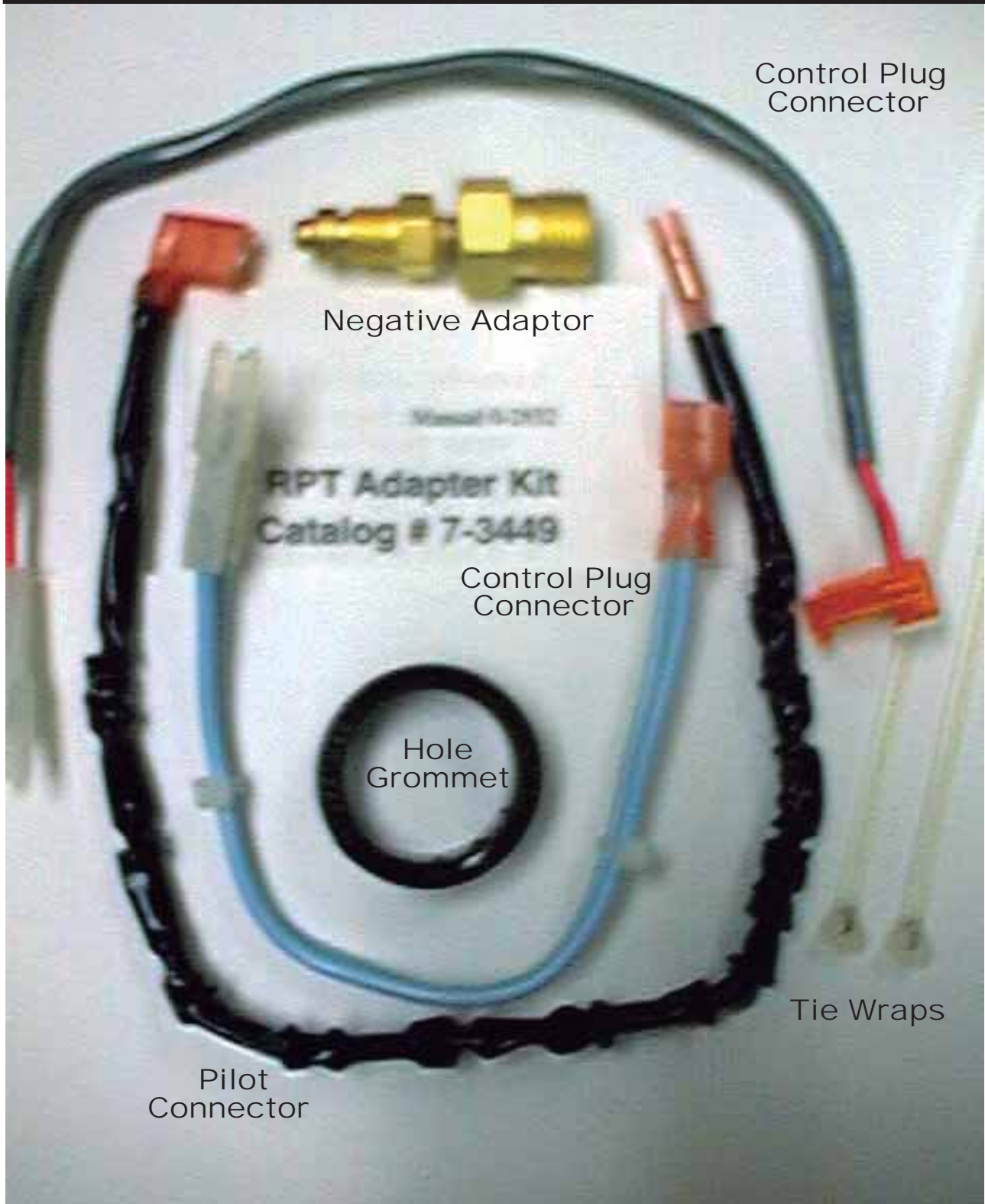

RPT Adapter Kit Catalog # 7-3450

Installation Instructions

General Information

This Replacement Torch Adapter Kit is to be used to connect the Thermal Dynamics Plasma RPT Series Cutting Torch to the following equipment:

Thermal Dynamics EconoPak 100

Parts Supplied

The following parts are included in this kit:

- Control Connector Wires with Connectors (1 ea)
- Pilot Lead Adapter with Insulation Sleeving (1 ea)

Installation

Install the Adapter Kit per the following procedure:

1. Turn OFF the power supply.
2. Disconnect the main input power to the power supply.
3. Remove the existing torch from the power supply, removing covers as required.
4. Connect the pilot wire (+) from the replacement torch to the Power Supply per the following procedure:
 - a. Measure back 2 inches (50.8 mm) on the pilot lead from the ring terminal and cut the pilot lead off at this point.
 - b. Strip the pilot lead wire insulation 9/32 inch.
 - c. Using the proper wire crimping tool, crimp the Pilot Lead Adapter onto the pilot lead at the butt splice.
 - d. Pull the Pilot Return Insulation Sleeving over the butt (in-line) splice.
 - e. Connect the end of the Pilot Return Adapter to the pilot terminal on the Power Supply.
5. Connect the Negative/Plasma Lead from the replacement torch to the Adapter Fitting. Slide the protective boot over the lead connection.
6. Connect the Control Connector Wire (see NOTE) to the two mating connectors on the replacement torch leads to the two mating connectors on the replacement torch leads.
7. Connect the PCB Header (10-pin connector) of the Control Connector Wires to the Power Supply.
8. Reinstall any covers removed (see WARNING).
9. Install the proper torch consumables for the Power Supply amperage.
10. Reconnect main input power to the Power Supply and turn the unit ON.
11. Set air pressure to 60 - 70 psi (4.1 - 4.8 bar).
12. Test torch for proper operation.

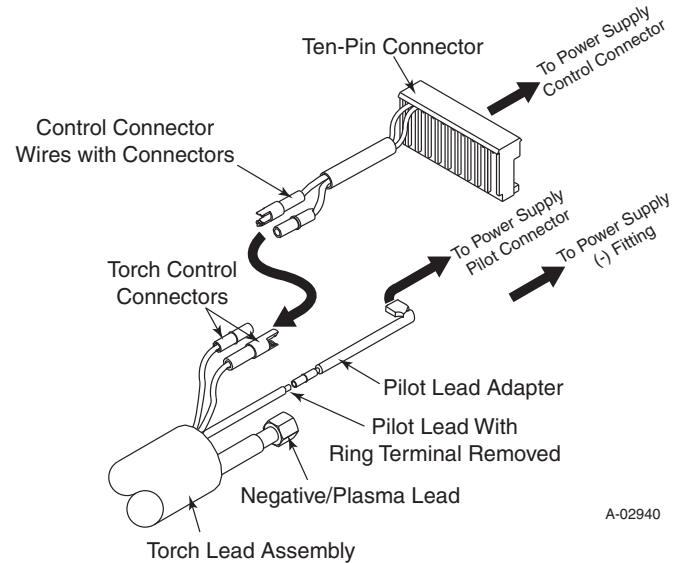

A-02940

NOTE

For Mechanized Systems refer to the Torch Control Cable Wiring Diagram in the Manual supplied with the RPT Torch.



WARNING

Make sure that the Control Connector Wires DO NOT contact the Negative/Plasma Lead Fitting after all leads are connected.

NOTE

Every effort has been made to provide complete and accurate information in this manual. However, the publisher does not assume and hereby disclaims any liability to any party for any loss or damage caused by errors or omissions in this manual, whether such errors result from negligence, accident or any other cause.

7-3450

RPT Adapter Kit





A THERMADYNE® Company

82 Benning Street, West Lebanon, NH 03784 USA
(603) 298-5711 • www.thermal-dynamics.com

Manual 0-2891

RPT Adapter Kits Catalog # 7-3454, 7-3457

Installation Instructions

General Information

These Replacement Torch Adapter Kits connect the Thermal Dynamics SL60 and SL100 Torch Leads with O2B fittings, or ATC Adapter Kit No. 7-5207, to the following equipment:

- Kit No. 7-3454: Hypertherm* powermax* 600, 800, 900; Max* 42, 43, 40cs
- Kit No. 7-3457: Miller* Spectrum* 650, 701, 2050

Supplied Parts

The kits include:

- Adapter Assembly
- Large Insulating Sleeve
- Small Insulating Sleeve
- Instructions

Assembly

CAUTION

The Adapter includes a protective end cap, held in place by a screw. Leave the cap and screw in place until the RPT Adapter Kit is completely connected to the ATC Adapter Kit.



WARNING

Disconnect primary power to the system before disassembling the torch or torch leads.

Connect the RPT Adapter Kit as follows:

1. Refer to the illustration. Remove 4 screws from the shell halves.
2. Separate the shell halves at the large end. Pull the shell halves away from each other. Twist them out of the connecting ring to remove them from the assembly.
3. Cut the plastic tie wrap off the sleeved wire on the ATC adapter or torch leads. Remove the sleeve. Disconnect the mating connectors from each other.
4. Cut the ring tongue connector off the doubled, sleeved wires on the ATC adapter or torch leads. Strip approximately 1/4 inch / 6 mm of insulation from the ends of the double wires on the ATC adapter or torch leads. Twist the wires together.

- Slide the large insulating sleeve onto the Negative / Plasma lead (only) on the ATC adapter or torch leads. All wiring must remain outside this insulating sleeve. Fold back approximately one third of the length of the sleeve for access to the Negative / Plasma lead fitting. Connect the Negative / Plasma lead on the ATC Adapter or torch leads to the fitting on the RPT Adapter Kit. Do not use thread sealant. Use a wrench to hold the gas fitting on the RPT Adapter Kit stationary. Use a second wrench to turn the Negative / Plasma lead on the Torch Lead Assembly or ATC Adapter Kit onto the RPT Adapter Kit fitting. Tighten securely.

CAUTION

Hold the RPT Adapter Kit Stationary. Turn only the Negative / Plasma lead fitting on the Torch Leads Assembly or ATC Adapter Kit. Turning the RPT Adapter Kit fitting can damage the RPT Adapter Kit.

- Unfold the large insulating sleeve to completely cover the Negative / Plasma Lead connection to the gas fitting on the RPT Adapter Kit. Slide the small insulating sleeve onto the RPT adapter wire which has a butt splice.

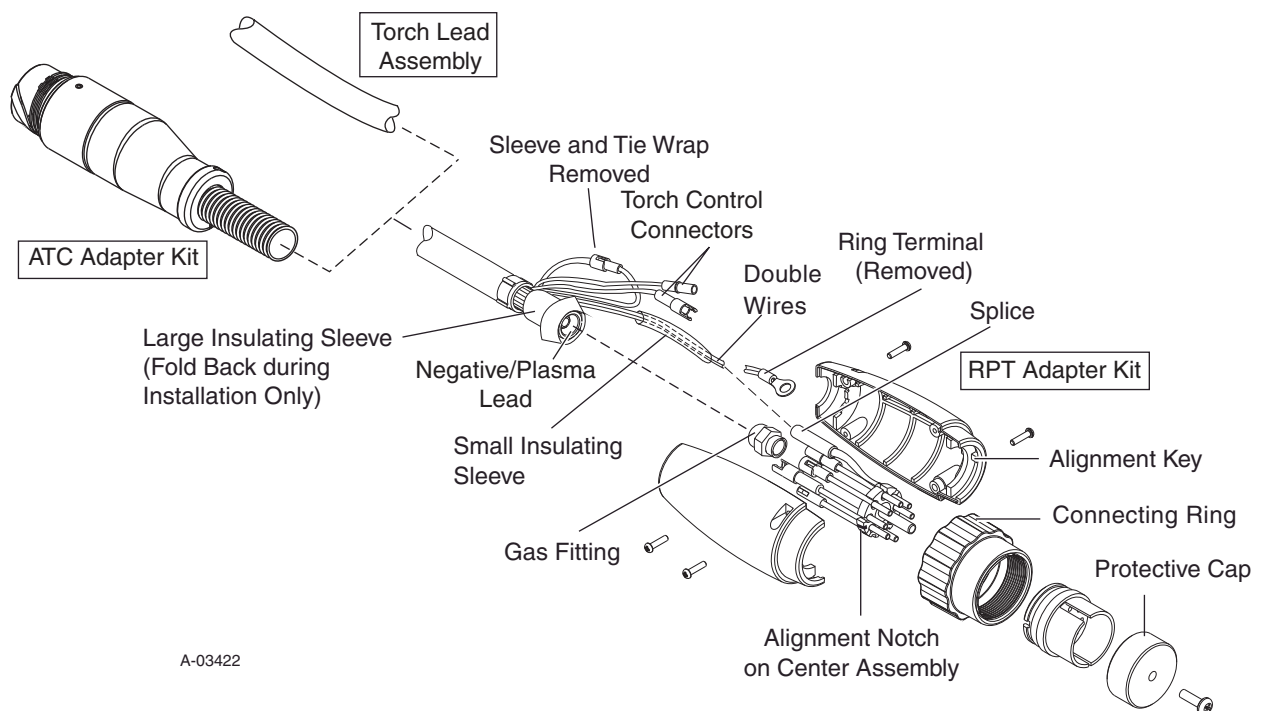

A-03422

- Join the mating connectors on the ATC Adapter or torch leads to the connectors on the RPT adapter. Use a crimping tool on the butt splice between the RPT adapter and the doubled, twisted wires on the ATC adapter or torch leads. Slide the small insulating sleeve over the butt joint.
- Position one shell half on the assembly. A groove inside the shell halves captures a ridge on the center assembly. Bend the back end of the first shell half toward the gas lead to enable it to fit into the assembly more easily. Alignment keys inside the shell halves must engage alignment notches on the center assembly.
- Arrange the wires and connectors evenly around the gas line.
- Position the second shell half on the assembly. Twist it into position to fit it into the center assembly. An alignment key inside the shell halves must engage an alignment notch on the center assembly.
- Press the halves of the shell together by hand. Ensure that there are no wires caught between the outer edges of the shells. Ensure that the shell halves fully engage. Fasten the shell halves together with four screws.
- Remove the protective cap and screw. Keep these for possible future use.

Installation and Use

1. Use the connecting ring on the ATC Adapter Kit to secure the male connector in place in the receptacle. Do not use tools. If resistance is felt, unthread the connecting ring, check the alignment of the connector and receptacle, and reassemble.
2. Install the proper torch consumables for the Power Supply amperage in the Torch. Follow instructions in the Torch Instruction Manual.
3. Connect the torch to the Power Supply.

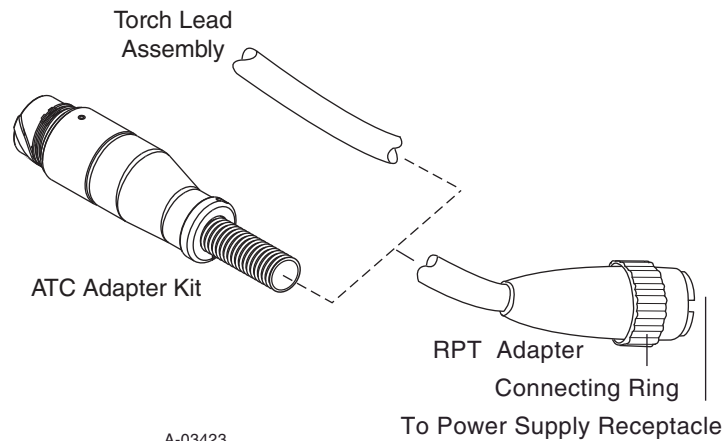

4. Reconnect main input power to the Power Supply and turn the unit ON.
5. Follow set - up directions in the Torch Instruction Manual.
6. Test torch for proper operation.

Connector Pin Layout

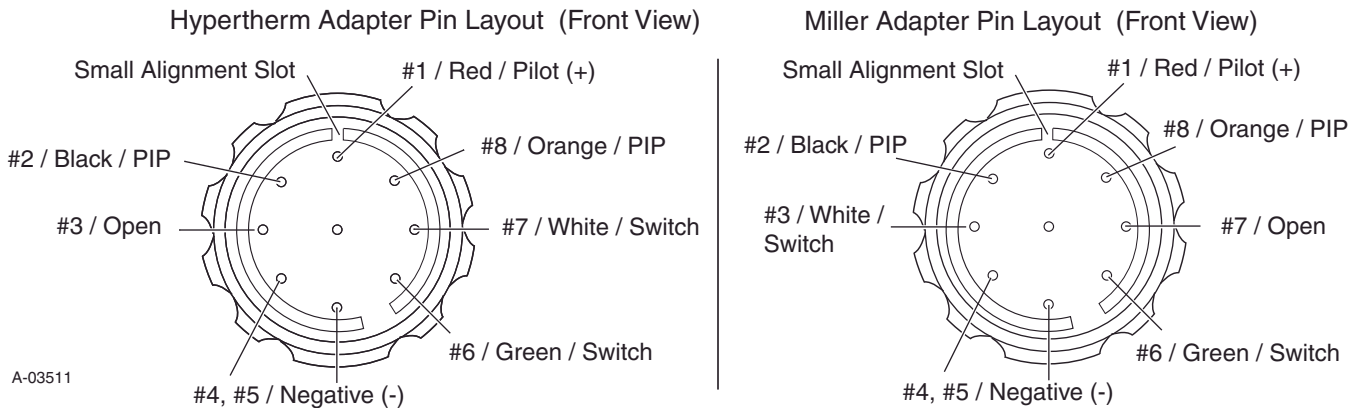

NOTE

Every effort has been made to provide complete and accurate information in this manual. However, the publisher does not assume and hereby disclaims any liability to any party for any loss or damage caused by errors or omissions in this manual, whether such errors result from negligence, accident or any other cause.

General Information

These Replacement Torch Adapter Kits connect the Thermal Dynamics SL60 or SL100 Torch Leads, or the ATC Adapter Kit No. 7-5207, to the following equipment:

- Kit No. 7-3455: Hypertherm* powermax* 1100
- Kit No. 7-3456: Miller* Spectrum* 3080

Supplied Parts

The kits include:

- Adapter Assembly
- Rubber Boot
- Large Insulating Sleeve
- Small Insulating Sleeve
- Instructions



WARNING

Disconnect primary power to the system before disassembling the torch or torch leads.

Assembly

Assemble the Adapter Kit as follows:

1. Remove four screws from the shell halves.
2. Pull the shell halves away from each other. Remove the shell halves from the assembly.

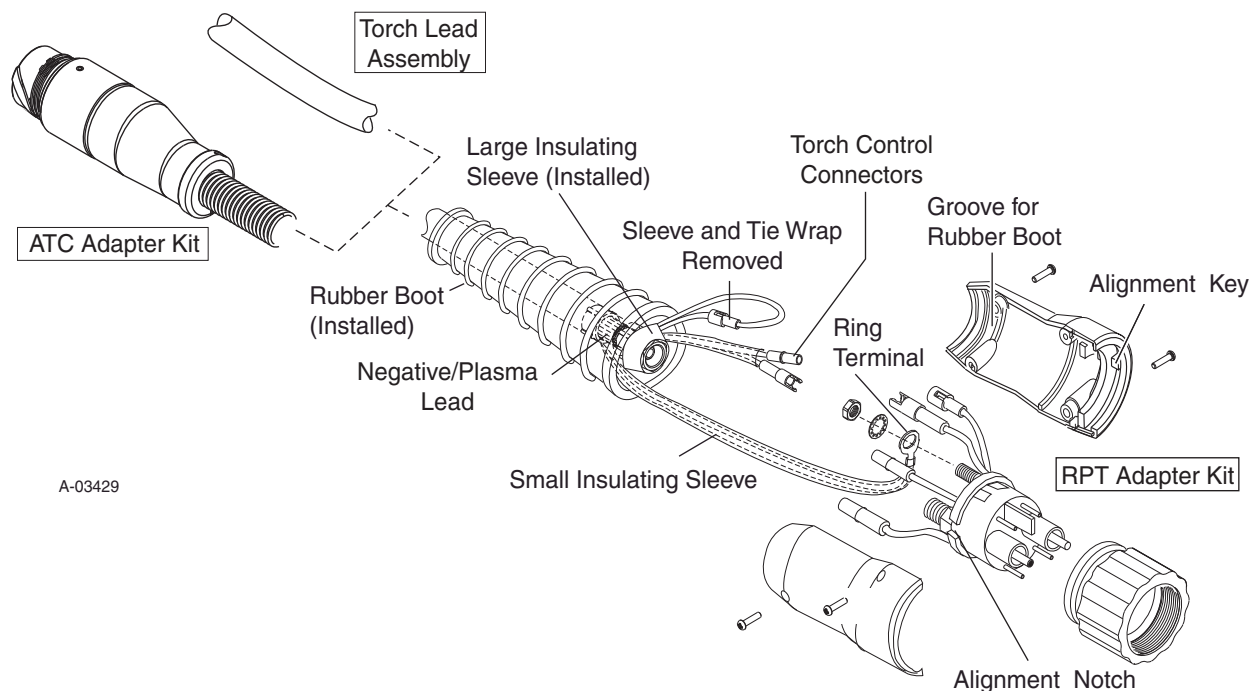

3. Slide the rubber boot, small end first, onto the torch leads or ATC Adapter. Slide the boot up far enough to allow access to the fittings and connections.
4. Cut the plastic tie wrap off the sleeved wires connected to each other on the torch leads or ATC Adapter. Remove the insulating sleeve.
5. Disconnect the connectors between the small joined wires on the torch leads or ATC Adapter. Remove the nut and internal star washer from the threaded stud on the RPT Adapter.
6. Slide the large insulating sleeve onto the negative/plasma fitting (only) on the torch leads or ATC Adapter. The sleeve must not enclose the torch control wiring. Fold the end of the insulator back (refer to illustration) temporarily for access to the negative/plasma fitting.
7. Connect the negative/plasma fitting on the torch leads or ATC Adapter to the gas fitting on the RPT Adapter. Do not use thread sealant. Use a wrench to hold the gas fitting on the RPT adapter stationary. Turn only the negative/plasma fitting on the torch leads or ATC Adapter. Tighten securely. Slide the insulating sleeve over the connection between the negative/plasma fitting and the RPT adapter gas fitting. Unfold the insulating sleeve to cover the connection.
8. Slide the small insulating sleeve over the torch leads or ATC Adapter wire with a ring tongue connector. Use the washer and hex nut to connect the ring tongue connector to the threaded stud on the RPT Adapter. Tighten securely. Bend the ring tongue connector to a 90° angle. Slide the insulating sleeve down to the washer and nut.
9. Match the mating wire connectors to connect the remaining torch leads or ATC Adapter wires to the RPT Adapter wires. There are two sizes and two types of connector.
10. Position one shell half on the assembly. Grooves inside the shell halves capture the center assembly and the rubber boot. Alignment keys inside the shell halves engage alignment notches on the center fitting. Rotate the shell half to ensure that the key engages the alignment notch.
11. Arrange the wires and connectors evenly around the gas line. Slide the rubber boot down from the torch leads or ATC Adapter. Ensure that the end ring on the boot engages the groove next to the screw holes inside the shell half.
12. Install the second shell half. Position the shell half to ensure that its alignment key engages the alignment notch on the center fitting. Press the halves of the shell together by hand. Ensure that there are no wires caught between the outer edges of the shells. Fasten the shell halves together with four screws.

Installation and Use

1. Press the male connector on the torch leads into the female receptacle on the ATC Adapter. Use the connecting ring on the torch leads connector to secure the male connector in place in the receptacle. Do not use tools. If resistance is felt, unthread the connecting ring, check the alignment of the connector and receptacle, and reassemble.
2. Install the proper torch consumables and set gas pressure according to the Torch Instruction Manual.
3. Connect the RPT Adapter to the Power Supply.

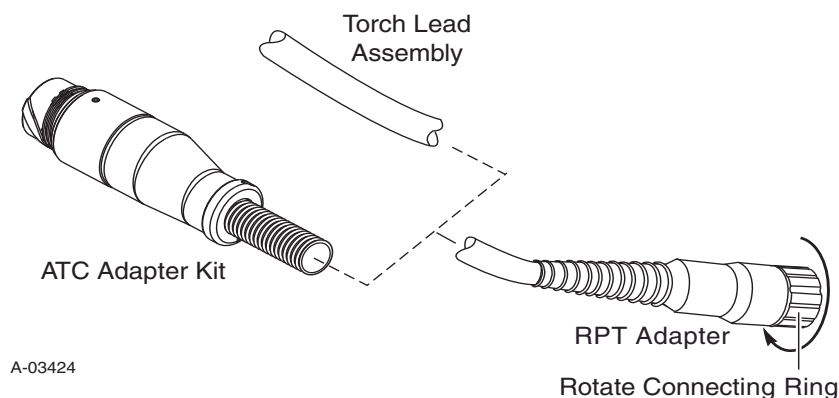

4. Reconnect main input power to the Power Supply and turn the unit ON.
5. Set air pressure according to directions in the Torch Instruction Manual.
6. Test torch for proper operation.

Connector Pin Layout

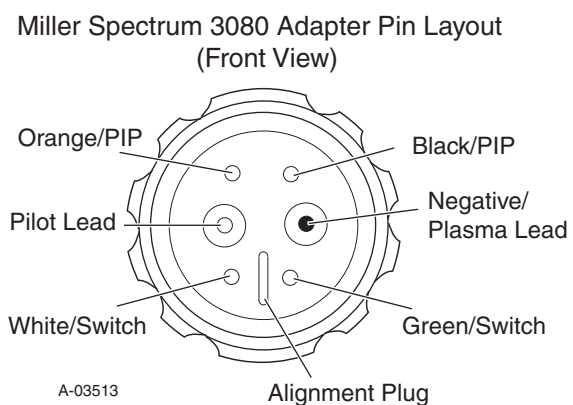
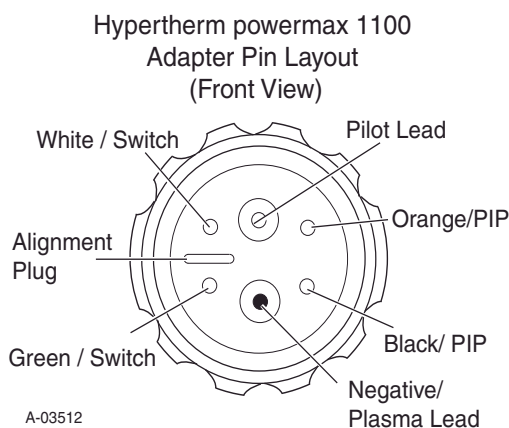

NOTE

Every effort has been made to provide complete and accurate information in this manual. However, the publisher does not assume and hereby disclaims any liability to any party for any loss or damage caused by errors or omissions in this manual, whether such errors result from negligence, accident or any other cause.

General Information

This Replacement Torch Adapter Kit is used to connect Thermal Dynamics RPT 1Torch Plasma Torches to the following equipment:

- HYPERTHERM® powermax® 1000, powermax® 1250

Supplied Parts

The kit includes:

- RPT Adapter Assembly - 1 each
- Screws - 2 each
- Strain Relief Shell Halves - 2 each
- Large Strain Relief Insert Half - 2 each
- Small Strain Relief Insert Half - 2 each
- Strain Relief Securing Nut - 1 each
- Instructions

Assembly

Connect the RPT Adapter Kit as follows per the illustration on next page:

1. Connect the torch leads gas fitting or ATC Adapter gas fitting to the RPT adapter gas fitting. Tighten securely. Do not use thread sealant.
2. Use mating connectors to connect the Adapter wires to the Torch Leads wires or ATC Adapter wires.
3. Slide the insulating sleeve back over the Pilot Lead wire(s) with the ring terminal. Cut the ring terminal from the wire(s) leaving as much wire as possible.
4. Leaving the insulating sleeve on the Pilot Lead wire(s), strip the wire(s) 1/4 inch / 6 mm from the ends.
5. Insert the end(s) of the Pilot Lead wire(s) into the butt splice provided on the Adapter wire. Crimp the splice to secure the Pilot Lead.
6. Slide the insulating sleeve over the butt splice connection.
7. Open the access door on the Power Supply. Disconnect the original torch from the Power Supply per instructions provided with the Power Supply.
8. Pass the Adapter Kit, attached to the torch leads or ATC Adapter, through the front opening of the Power Supply.
9. Slide the Strain Relief Securing Nut onto the adapter assembly. Rotate as needed to fit the nut onto the assembly.
10. Connect the multi-pin connector on the Adapter to the receptacle on the Power Supply. Ensure that the connector fits securely in the receptacle.

NOTE

RPT Adapter Kit can be used with 1Torch O2B or ATC style Torches only.



WARNING

Disconnect primary power to the system before disassembling the power supply, torch or torch leads.

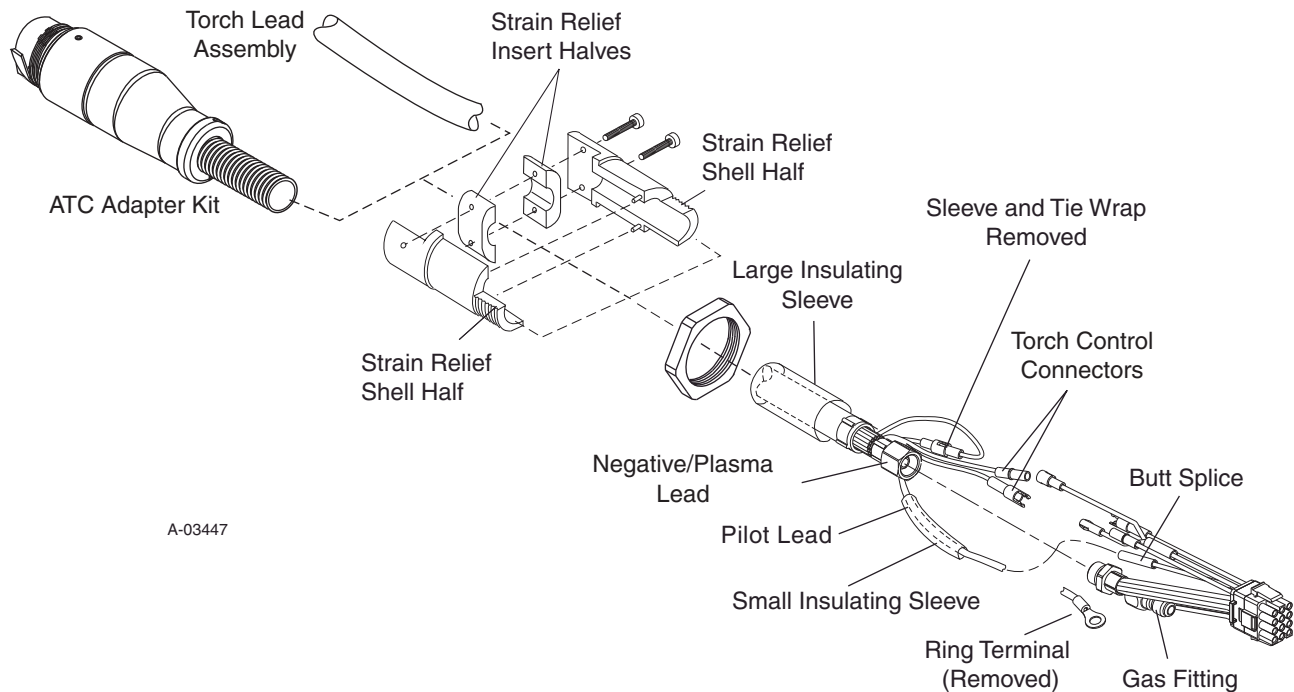

A-03447

11. Pull back the locking ring on the Power Supply leads receptacle. Insert the Adapter gas fitting into the receptacle. Release the locking ring. Ensure that the connection is secure.
12. Fit the Strain Relief Shell halves onto the torch lead, outside the front panel of the Power Supply. Align the halves with the torch connector opening on the front of the Power Supply.
13. Slide the Strain Relief Shell along the torch leads to fit the threaded end of the Strain Relief Shell into the receptacle.
14. Select a set of Strain Relief Inserts according to the size of the torch leads or ATC Adapter being connected. SL60 leads use the inserts with the smaller inner diameter; SL100 leads and the ATC Adapter use the inserts with the larger inner diameter.
15. Position the Strain Relief Inserts on the torch leads or ATC Adapter. Position the inserts in the slot in the Strain Relief Shell Assembly, and loosely secure the inserts into the Assembly with the screws provided. Press the assembly fully into the receptacle on the Power Supply.
16. Tighten the screws securing the Strain Relief Assembly together. Check for a secure fit of the Strain Relief Assembly to the Power Supply. Secure the assembly with the locking nut.
17. Close the Power Supply Access Door to the torch leads connections.
18. In applications with the ATC Adapter, connect the torch leads to the ATC Adapter by pressing the male connector on the torch leads into the female receptacle on the ATC Adapter.

Operation

1. Install the proper torch consumables for the Power Supply amperage.
2. Reconnect input power and turn ON the unit.
3. Set proper gas pressure or flow.
4. Test torch for proper operation.

NOTE

Every effort has been made to provide complete and accurate information in this manual. However, the publisher does not assume and hereby disclaims any liability to any party for any loss or damage caused by errors or omissions in this manual, whether such errors result from negligence, accident or any other cause.

General Information

This kit connects Thermal Dynamics Torches equipped with O2B connectors, or the ATC Adapter Kit, to the following Power Supplies:

- L-TEC* PowerCut 875*, PowerCut 1125*, PowerCut 1500*

Supplied Parts

The kit includes:

- Adapter Assembly
- Hex Nut
- Flare Fitting
- Connection Cover
- Jumper Assemblies (2)
- Strain Relief
- Mounting Hardware
- Instructions



WARNINGS

Disconnect primary input power to the system before starting the installation.

Shut off the gas supply and bleed down the system.

Only a qualified technician should perform this procedure.

Procedure

A. Preparation

1. Disconnect and remove the original torch per the Power Supply operator's manual.
2. Remove the securing nut from the Strain Relief provided in this kit.
3. Install the Strain Relief on the torch connections cover included in this kit. Secure the Strain Relief with the securing nut.
4. Pass the end of the Torch Leads or ATC Adapter Kit through the Strain Relief. Do not tighten the strain relief dome nut.
5. Use mating fittings on the two wire assemblies provided in this kit to connect the assemblies to the mating connectors on the Torch Leads or ATC Adapter Kit.

B. Installation

1. Thread the large gas fitting from this adapter kit onto the ATC Adapter or Torch Leads O2B fitting. Tighten securely. Do not use sealant.
2. Connect the large adapter fitting to the gas connector on the Power Supply. Tighten securely. Do not use sealant.
3. Refer to the illustration. Install the flare fitting included in this kit on the smaller Power Supply connection fitting. Tighten securely. Capture the ring terminal (from the ATC Adapter Kit Leads or Torch Leads) between the flare fitting and the hex nut supplied in this kit. Tighten securely. Connect the small adapter fitting to the flare fitting. Tighten securely. Do not use sealant.

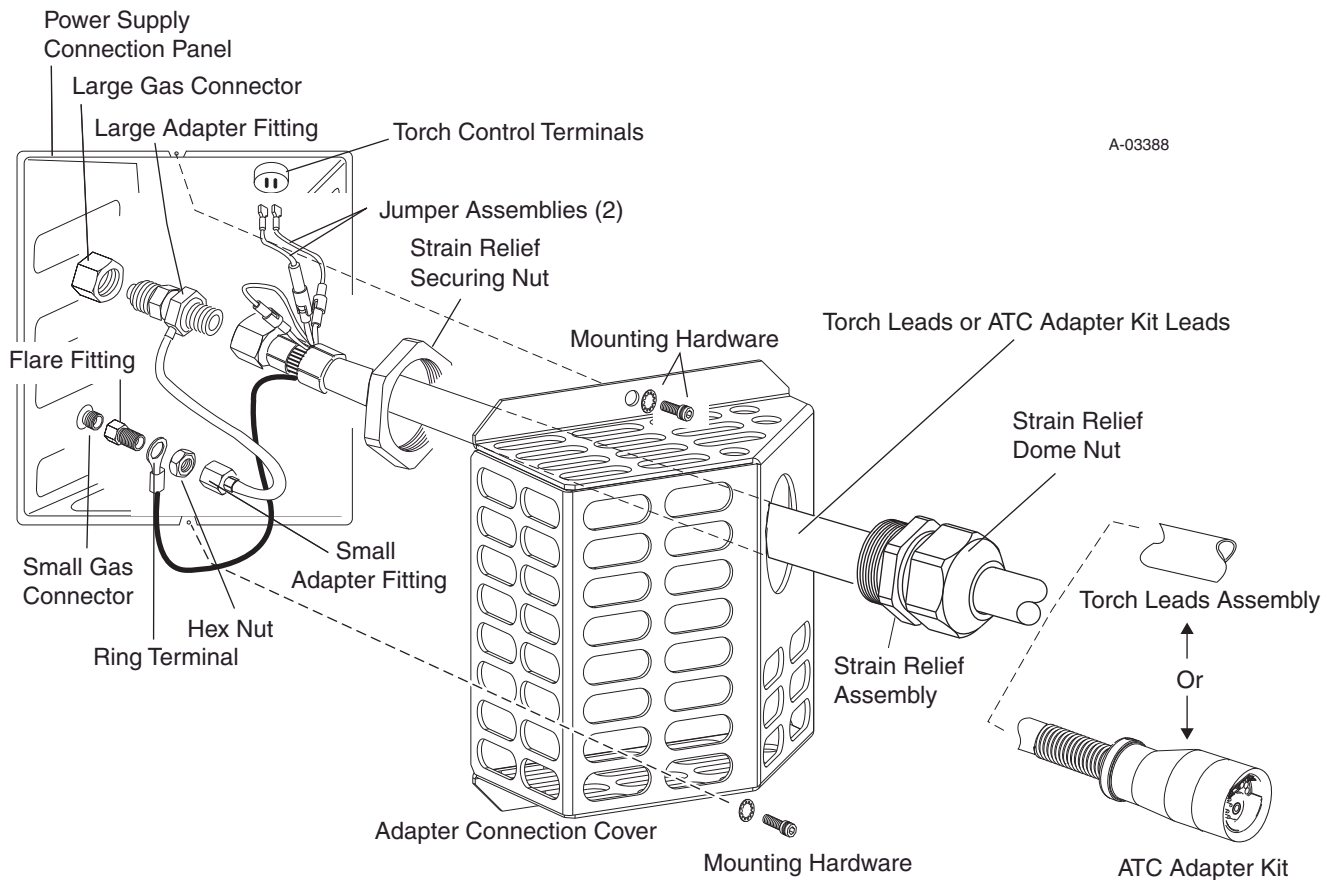

4. Connect the adapter wire assemblies to the torch control terminals on the Power Supply. Refer to the illustration.
5. Slide the Connection Cover along the ATC Adapter Leads or Torch Leads to position it against the Power Supply Connection Panel. Attach the Connection Cover to the Power Supply with hardware provided in this kit. Ensure that all wires are inside the Connection Cover.
6. Tighten the Strain Relief Dome Nut onto the Strain Relief securely by hand. Do not overtighten.
7. In installations using the ATC Adapter, connect the male connector on the Torch Leads to the female receptacle on the ATC Adapter per instructions provided with the ATC Adapter.

C. Operation

1. Install the proper torch consumables.
2. Connect primary input power. Turn on the gas supply.
3. Set proper gas pressure and flow per the Torch Instruction Manual.
4. Test for proper operation.

NOTE

Every effort has been made to provide complete and accurate information in this manual. However, the publisher does not assume and hereby disclaims any liability to any party for any loss or damage caused by errors or omissions in this Manual, whether such errors result from negligence, accident, or any other cause.

General Information

These instructions cover Thermal Dynamics RPT Adapter Kit No. 7-3476. The kit connects 1 Torch SL60 or SL100 Torches equipped with O2B connectors, or the ATC Adapter Kit, to the following Power Supplies:

- Century 50
- Hypertherm* Max 40CS (without disconnect)
- Snap-On YA5550

Supplied Parts

The kit includes:

- Negative / Plasma Adapter Fitting
- Plasma Line
- Wire Harness with Connectors - 2
- Negative Connector
- Insulating Sleeve (large)
- Strain Relief
- Instructions



WARNINGS

Disconnect primary input power to the system before starting the installation.

Shut off the gas supply and bleed down the system.

Only a qualified technician should perform this procedure.

Procedure

A. Preparation

1. Remove the Power Supply Cover per the Power Supply Manual.
2. Label and disconnect all original torch connections. Remove the original torch from the Power Supply.
3. Remove the Strain Relief securing nut from the Strain Relief provided in this kit.
4. Slide the Strain Relief onto the Torch Leads or ATC Adapter Kit. If necessary for strain relief installation, remove the insulation sleeve covering two joined wires on the Torch Leads or Adapter. Disconnect the joined wires.

B. Installation

1. Pass the end of the leads or ATC Adapter through the torch leads opening in the Power Supply.
2. Inside the Power Supply, slide the Strain Relief securing nut onto the Leads or Adapter. Tighten the securing nut onto the Strain Relief to secure the strain relief to the Power Supply.
3. Refer to the illustration. Slide the insulating sleeve provided in this kit onto the Torch Leads or ATC Adapter Kit Negative / Plasma fitting (only). Do not enclose the wires.
4. Connect the negative / plasma fitting from this adapter kit to the ATC Adapter or Leads plasma fitting. Do not use sealant. Tighten securely.

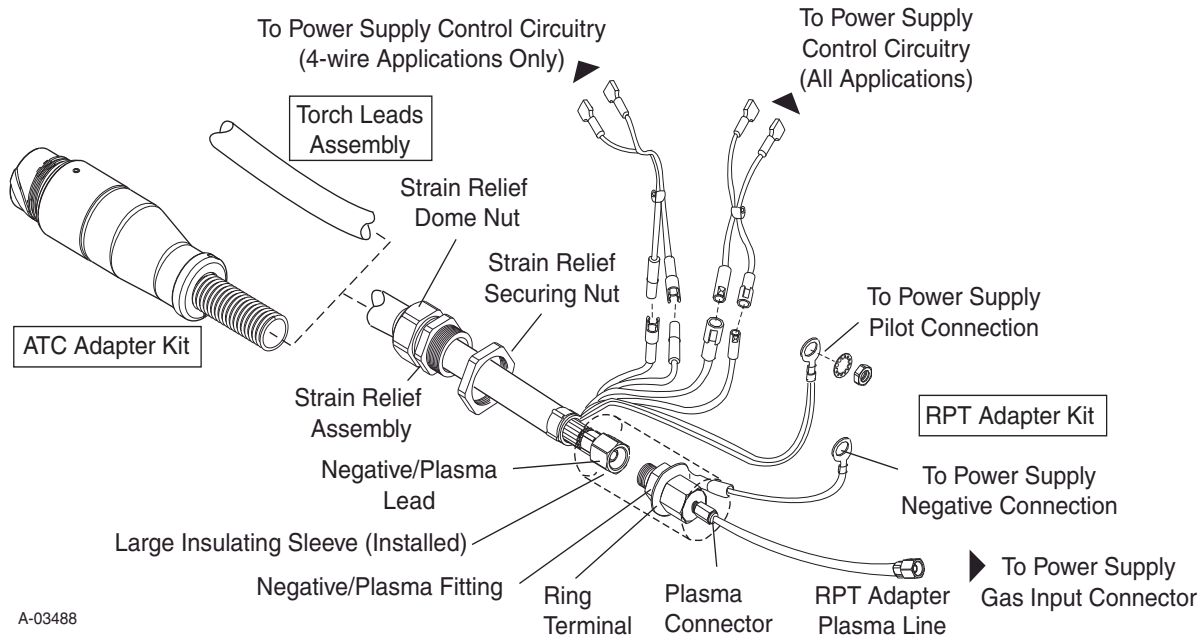

5. Connect the ring terminal on the negative / plasma fitting wire to the negative connection on the power supply.
6. Tighten the nut on the negative / plasma fitting securing the large ring terminal.
7. Slide the large insulating sleeve over the Torch Leads or ATC Adapter plasma fittings, and the negative / plasma fitting. The sleeve must completely cover the fittings on both the Leads or ATC Adapter, and the negative / plasma fitting.
8. Connect the pilot wire (+) on the ATC Adapter or Torch Leads wire to the pilot connector on the Power Supply.

9. **In 4-wire Power Supply applications only**, remove the insulating sleeve covering two joined wire connectors with mating connectors on the Torch Leads or the ATC Adapter if not previously removed. Separate the connectors.

In 2-wire Power Supply applications, reconnect and insulate the two Torch Leads or ATC Adapter wires which were originally joined with mating connectors if they were disconnected for any reason.

10. Use the RPT Adapter Kit wire harness(es) to connect the Torch Leads or the ATC Adapter to the Power Supply per the following chart.

Wire Connections			
2-Wire Power Supply		4-Wire Power Supply	
Leads Wire	Power Supply Connection	Leads Wire	Power Supply Connection
Black	To Power Supply PIP Circuit	Black	To Power Supply PIP Circuit
White	To Power Supply Torch Switch Circuit	White	To Power Supply Torch Switch Circuit
Orange	Connected Together.	Orange	To Power Supply PIP Circuit
Green	Not Connected to Power Supply.	Green	To Power Supply Torch Switch Circuit

11. Connect the plasma line provided in this kit to the Power Supply plasma connector. Do not use sealant. Tighten securely.
12. Cut the plasma line to length as needed. Connect the plasma line to the plasma connector on the RPT Adapter Kit negative / plasma fitting. Push in on the connector, insert the plasma line fully, and release the connector. Check for a secure connection.
13. Ensure that there is no strain on any of the connections. Secure the Strain Relief Dome Nut to the Strain Relief by hand. Do not overtighten.
14. Reinstall the Power Supply cover.

C. Operation

1. Connect primary input power. Turn on the gas supply.
2. Set proper gas pressure and flow per the Torch Instruction Manual.
3. Install proper consumables per the Torch Instruction Manual.
4. Test for proper operation.

NOTE

Every effort has been made to provide complete and accurate information in this manual. However, the publisher does not assume and hereby disclaims any liability to any party for any loss or damage caused by errors or omissions in this Manual, whether such errors result from negligence, accident, or any other cause.

General Information

These instructions cover Thermal Dynamics RPT Adapter Kit No. 7-3477. The kit connects 1Torch SL60 or SL100 Torches equipped with O2B connectors, or the ATC Adapter Kit, to the following Power Supplies:

- Hypertherm* powermax* 380
- Miller* Spectrum* 375

Supplied Parts

The kit includes:

- Gas Line Adapter Fitting with Gas Line
- Power Wire Harness with Connector
- Control Wire with Connector
- Insulating Sleeve
- Strain Relief
- Instructions



WARNINGS

Disconnect primary input power to the system before starting the installation.

Shut off the gas supply and bleed down the system.

Only a qualified technician should perform this procedure.

Procedure

A. Preparation

1. Remove the Power Supply Cover per the Power Supply Manual.
2. Disconnect the original torch per the Power Supply Manual.
3. Disconnect the inductor wire connected to the terminal marked 'L2 RED' on the Power Supply circuit board.
4. Disassemble the Strain Relief provided in this kit.
5. Slide the Strain Relief dome nut (only) onto the Torch Leads or ATC Adapter Kit.
6. Fold back the shortest wire connector on the Torch Leads or ATC Adapter Kit.
7. Slide the Strain Relief over the Leads or Adapter fittings.
8. Straighten the short wire folded back previously.

B. Installation

1. Pass the end of the leads or ATC Adapter through the torch leads opening in the Power Supply front panel.
2. Slide the Strain Relief securing nut over the Leads or Adapter. Tighten the securing nut onto the Strain Relief to secure the strain relief to the Power Supply front panel.
3. Slide the insulating sleeve provided in this kit onto the Torch Leads or ATC Adapter Kit Negative/Plasma lead (only). Do not enclose the wires.
4. Connect the gas fitting from this adapter kit to the ATC Adapter or Leads gas fitting. Do not use sealant. Tighten securely.
5. Connect the adapter gas tube to the gas connector on the Power Supply. Push in on the connector, insert the gas tube fully, and release the connector. Check for a secure connection.

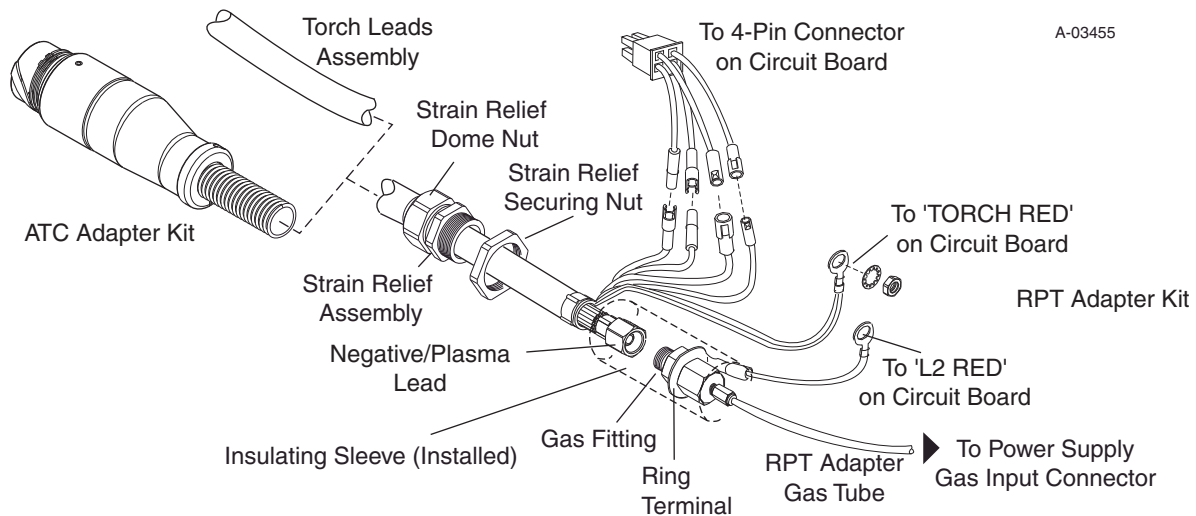

6. Connect the ring terminal on the RPT Adapter kit wire and the inductor wire disconnected previously to the 'L2 RED' terminal on the Power Supply circuit board.
7. Tighten the nut on the RPT Adapter Kit securing the large ring terminal to the gas fittings.
8. Slide the large insulating sleeve over the Torch Leads or ATC Adapter gas fittings, and the RPT Adapter Kit gas fitting. The sleeve must completely cover the fittings on both the Leads or ATC Adapter, and the RPT Adapter Kit.
9. Connect the ring terminal on the ATC Adapter or Torch Leads wire to the 'TORCH RED' terminal on the Power Supply circuit board.
10. Remove the insulating sleeve covering two joined wire connectors on the Torch Leads or the ATC Adapter. Separate the connectors.
11. Use the mating connectors on the RPT Adapter kit wire harness to connect the Adapter wires to the Torch Leads wires or the ATC Adapter wires. There are two types of connector.
12. Connect the RPT Kit Adapter wire harness 4-pin connector to the receptacle on the Power Supply circuit board.
13. Ensure that there is no strain on any of the connections. Secure the Strain Relief Dome Nut to the Strain Relief by hand. Do not over-tighten.
14. Reinstall the Power Supply cover.

C. Operation

1. Connect primary input power. Turn on the gas supply.
2. Set proper gas pressure and flow per the Torch Instruction Manual.
3. Test for proper operation.

NOTE

Every effort has been made to provide complete and accurate information in this manual. However, the publisher does not assume and hereby disclaims any liability to any party for any loss or damage caused by errors or omissions in this Manual, whether such errors result from negligence, accident, or any other cause.

General Information

These instructions cover Thermal Dynamics RPT Adapter Kit No. 7-3477. The kit connects 1Torch SL60 or SL100 Torches equipped with O2B connectors, or the ATC Adapter Kit, to the following Power Supplies:

- Hypertherm* powermax* 380
- Miller* Spectrum* 375

Supplied Parts

The kit includes:

- Gas Line Adapter Fitting with Gas Line
- Power Wire Harness with Connector
- Control Wire with Connector
- Insulating Sleeve
- Strain Relief
- Instructions



WARNINGS

Disconnect primary input power to the system before starting the installation.

Shut off the gas supply and bleed down the system.

Only a qualified technician should perform this procedure.

Procedure

A. Preparation

1. Remove the Power Supply Cover per the Power Supply Manual.
2. Disconnect the original torch per the Power Supply Manual.
3. Disconnect the inductor wire connected to the terminal marked 'L2 RED' on the Power Supply circuit board.
4. Disassemble the Strain Relief provided in this kit.
5. Slide the Strain Relief dome nut (only) onto the Torch Leads or ATC Adapter Kit.
6. Fold back the shortest wire connector on the Torch Leads or ATC Adapter Kit.
7. Slide the Strain Relief over the Leads or Adapter fittings.
8. Straighten the short wire folded back previously.

B. Installation

1. Pass the end of the leads or ATC Adapter through the torch leads opening in the Power Supply front panel.
2. Slide the Strain Relief securing nut over the Leads or Adapter. Tighten the securing nut onto the Strain Relief to secure the strain relief to the Power Supply front panel.
3. Slide the insulating sleeve provided in this kit onto the Torch Leads or ATC Adapter Kit Negative/Plasma lead (only). Do not enclose the wires.
4. Connect the gas fitting from this adapter kit to the ATC Adapter or Leads gas fitting. Do not use sealant. Tighten securely.
5. Connect the adapter gas tube to the gas connector on the Power Supply. Push in on the connector, insert the gas tube fully, and release the connector. Check for a secure connection.

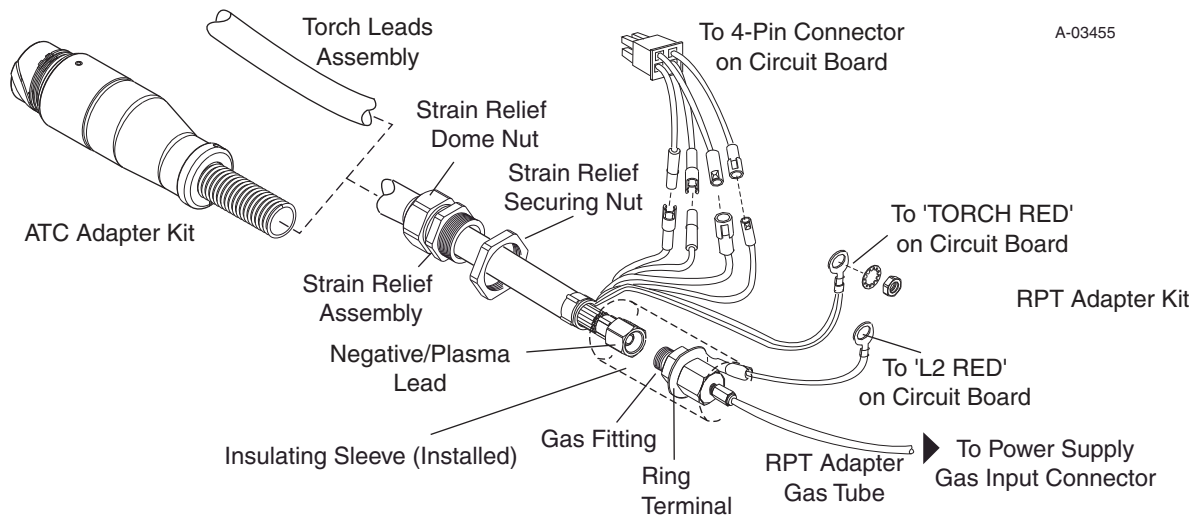

6. Connect the ring terminal on the RPT Adapter kit wire and the inductor wire disconnected previously to the 'L2 RED' terminal on the Power Supply circuit board.
7. Tighten the nut on the RPT Adapter Kit securing the large ring terminal to the gas fittings.
8. Slide the large insulating sleeve over the Torch Leads or ATC Adapter gas fittings, and the RPT Adapter Kit gas fitting. The sleeve must completely cover the fittings on both the Leads or ATC Adapter, and the RPT Adapter Kit.
9. Connect the ring terminal on the ATC Adapter or Torch Leads wire to the 'TORCH RED' terminal on the Power Supply circuit board.
10. Remove the insulating sleeve covering two joined wire connectors on the Torch Leads or the ATC Adapter. Separate the connectors.
11. Use the mating connectors on the RPT Adapter kit wire harness to connect the Adapter wires to the Torch Leads wires or the ATC Adapter wires. There are two types of connector.
12. Connect the RPT Kit Adapter wire harness 4-pin connector to the receptacle on the Power Supply circuit board.
13. Ensure that there is no strain on any of the connections. Secure the Strain Relief Dome Nut to the Strain Relief by hand. Do not over-tighten.
14. Reinstall the Power Supply cover.

C. Operation

1. Connect primary input power. Turn on the gas supply.
2. Set proper gas pressure and flow per the Torch Instruction Manual.
3. Test for proper operation.

NOTE

Every effort has been made to provide complete and accurate information in this manual. However, the publisher does not assume and hereby disclaims any liability to any party for any loss or damage caused by errors or omissions in this Manual, whether such errors result from negligence, accident, or any other cause.

1Torch Adapter Kit 7-3480

Installation Instructions

General Information

This kit connects Thermal Dynamics 1Torch Models SL60 or SL100 Torches, or the Thermal Dynamics ATC Adapter, to Hypertherm* powermax* 600 power supplies with internal torch connections.

These instructions are important for the proper installation of the Torches. Read the instructions thoroughly before attempting the installation. Only a qualified technician should perform the installation of this kit. Keep these instructions for reference.

Parts Supplied

The kit includes:

- O2B Adapter Fitting with Wire Harness
- Control Wire Harness
- Barrel Crimp
- Strain Relief
- Instructions

Installation



WARNINGS

Disconnect primary power to the system before disassembling the torch or torch leads.

DO NOT touch any internal torch parts while the AC indicator light of the Power Supply is ON.

1. Remove the Power Supply cover per manufacturer's instructions.
2. Disconnect and remove the original torch from the Power Supply per manufacturer's instructions. Remove the brass fitting from the power supply solenoid connection. Keep the C-clip which secures the brass fitting to the solenoid.

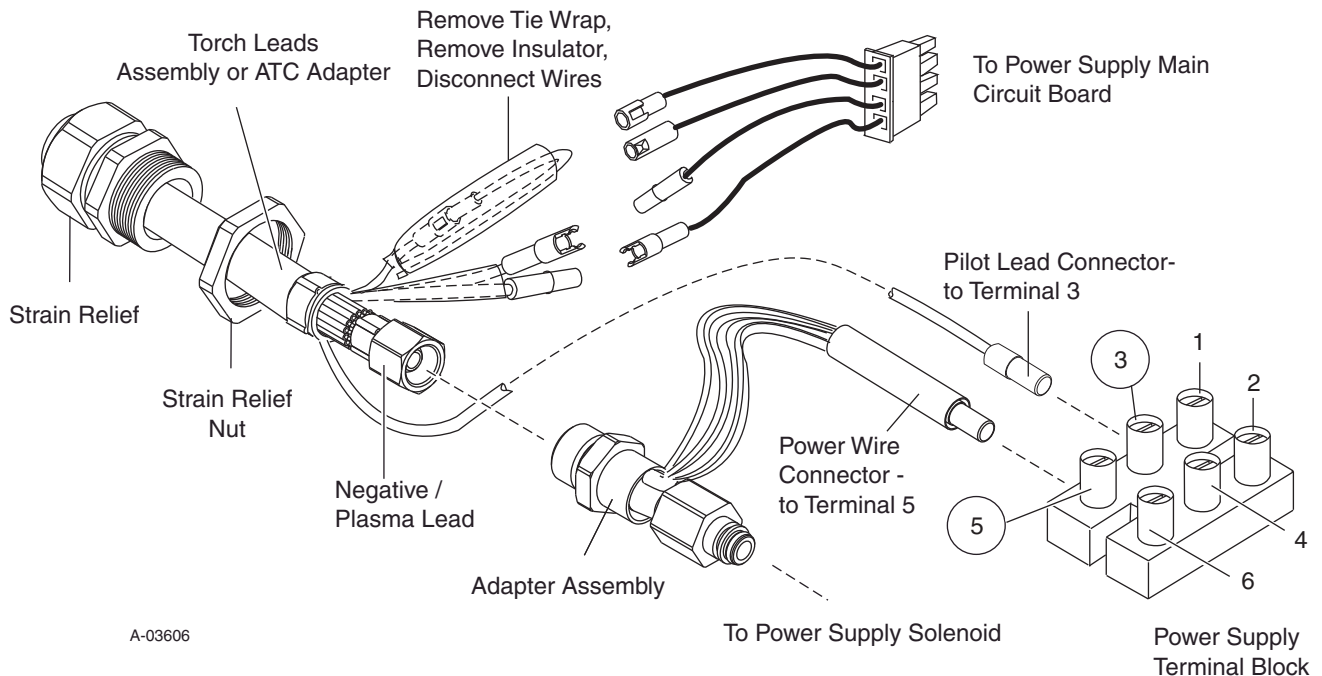

A-03606

3. The torch leads or ATC Adapter includes a pilot wire terminated with a ring-tongue terminal. Cut this terminal off the wire. Strip back approximately 11/16 inch (17 mm) of insulation from the end of the wire. Double the stripped end of the wire back onto itself. Use a crimping tool to attach the barrel crimp included in this kit to the end of the pilot wire. Check for a secure connection between the crimp and the wire.
4. The torch leads or ATC Adapter includes two wires covered with an insulating sleeve and joined with mating connectors. Remove the tie wrap securing the insulating sleeve in place. Remove the insulating sleeve and disconnect the mating connectors.
5. Remove the nut from the strain relief assembly.
6. Install the strain relief on the Replacement Torch leads or ATC Adapter. It may be necessary to twist the strain relief back and forth while sliding it onto the leads or ATC Adapter.
7. Pass the Torch Leads or ATC Adapter through the torch leads access opening in the power supply front panel. Loosely thread the Strain Relief Nut onto the Strain Relief. Do not tighten.
8. Connect the O2B Adapter Fitting (with wire harness) to the Plasma Fitting on the torch leads or ATC Adapter. Tighten securely.
9. Ensure that the O-ring is in place on the Adapter Connector.
10. Press the Adapter Connector into the power supply solenoid connection. Secure the fitting in place with the C-clip removed to disconnect the original torch. Test for a secure connection between the fitting and the solenoid.
11. Tighten the Strain Relief Nut onto the Strain Relief securely. Test the torch leads or ATC Adapter leads assembly to ensure that the strain relief holds the leads or adapter leads securely.
13. Refer to the illustration. Install the pilot lead wire (with barrel crimp) in terminal #3 in the terminal block just above the power supply solenoid. Tighten the securing screw. Check for a secure connection.
14. Refer to the illustration. Install the power wire connector from the torch adapter (4 wires terminated in a barrel crimp) in terminal #5 in the terminal block just above the power supply solenoid. Tighten the securing screw. Check for a secure connection.
15. Connect the mating wire connectors on the separate 4-wire harness assembly provided in this kit to the connectors on the torch leads assembly or ATC Adapter.
16. Connect the receptacle on the 4-wire harness assembly to the power supply main circuit board. Press the connector into place securely.
17. Reinstall the power supply cover per manufacturer's instructions.
18. Check the torch for proper consumables per the torch manual.
19. Connect primary input power to the power supply. Test the power supply for proper operation.
20. Set gas pressure per the torch manual.
21. Test the torch for proper operation.

NOTE

Every effort has been made to provide complete and accurate information in this manual. However, the publisher does not assume and hereby disclaims any liability to any party for any loss or damage caused by errors or omissions in this Manual, whether such errors result from negligence, accident, or any other cause.

HERMAL DYNAMICS®

A THERMADYNE® Company

82 Benning Street, West Lebanon, NH 03784 USA
(603) 298-5711 • www.thermal-dynamics.com

1Torch Adapter Kit Catalog No. 7-3481

Installation Instructions

General Information

This kit connects Thermal Dynamics 1Torch Models SL60 or SL100, or the Thermal Dynamics ATC Adapter Kit, to Hypertherm® powermax® 800/900 Power Supplies with front panel-mounted quick disconnection fittings.

Installation involves removing the quick-disconnection fitting installed on the power supply, and replacing it with items included in this kit.

Parts Supplied

The kit includes:

- Torch Adapter Assembly
- Lead Support Bracket
- Strain Relief with Nut
- Control Wire Harness
- Washer
- Wire Tie
- Instructions

Installation Procedure



WARNING

Only a qualified technician should install this kit.

A. Removing Original Connection Fittings

1. Shut off primary input power to the power supply. Disconnect input power cord.
2. Shut off gas input to the power supply; bleed down the system.
3. Disconnect the torch from the power supply per power supply manufacturers' instructions.
4. Remove power supply cover per power supply manufacturers' instructions.

5. Loosen the screw securing the red wire from the quick disconnect fitting to the bottom left corner of the power supply pilot relay. Detach the wire from the relay.
6. Disconnect the quick-disconnect double white wires (connected with a ring terminal) from the transformer (at the lower left front corner of the power supply).
7. Disconnect the gas line from the elbow fitting on the quick-disconnect fitting.
8. Cut the two blue and two purple wires leading from the quick-disconnect fitting to the power supply control circuitry. Cut these wires approximately 1-1/2" back from the quick-disconnect fitting.
9. Strip back the insulation on the blue and purple wires, approximately 1/4".
10. Remove bolts in the bottom left and right corners of the power supply front panel. Carefully pull the bottom edge of the front panel away from the power supply just enough for access to the hardware securing the quick-disconnect fitting to the inner (metal) front panel of the power supply assembly.
11. Remove the hardware securing the quick-disconnect fitting to the inner (metal) front panel of the power supply.
12. Carefully remove the quick-disconnect fitting by moving it down between the inner and outer front panels of the power supply. Set the fitting aside.
13. Press the power supply outer front panel against the inner panel. Secure front panels with hardware removed previously.

B. Installing Adapter Kit

1. On the torch leads or adapter leads, remove the tie wrap and insulation sleeve covering two wires joined with mating connectors.
2. Remove the nut from the Strain Relief assembly.
3. Install the Strain Relief on the torch leads or adapter leads. The Strain Relief includes an inner rubber ring. It may be easiest to install the strain relief by removing the rubber ring and stretching it over the wires and fittings on the end of the torch leads or adapter leads.
4. Pass the torch leads or adapter leads through the hole in the front of the power supply. Install the strain relief nut on the leads. Secure the strain relief in place with the strain relief securing nut. Do not tighten the strain relief onto the leads.



WARNING

THIS ADAPTER KIT INCLUDES A LEAD SUPPORT BRACKET WHICH MUST BE INSTALLED AS SHOWN AND DESCRIBED FOR PROPER TORCH OPERATION.

5. Refer to the illustration. Place the lead support bracket on the RPT Adapter fitting (with power supply transformer lead). Position the fitting and bracket diagonally into the opening in the power supply chassis just above the relay. Rotate the bracket and fitting to a vertical position. Slots in the top and bottom edges of the support bracket must engage the edges of the opening in the power supply chassis just above the relay.
6. Connect the negative / plasma lead (O2B fitting) on the torch leads or adapter leads to the torch adapter. Use wrenches to tighten the fittings. Do not use a tool on the inner nut securing the large ring terminal to the adapter fitting.

CAUTION

Do not use Teflon tape as a sealant on these fittings, as small particles of the tape can break off and block the small passages in the torch.

7. Test the positioning of the RPT Adapter in the chassis opening. The Adapter must not be able to contact any other power supply parts.
8. The adapter fitting includes a wire with a ring terminal. Connect this wire to the transformer assembly in the lower left front corner of the power supply, along with the wire disconnected from the transformer when removing the original quick-disconnect fitting.

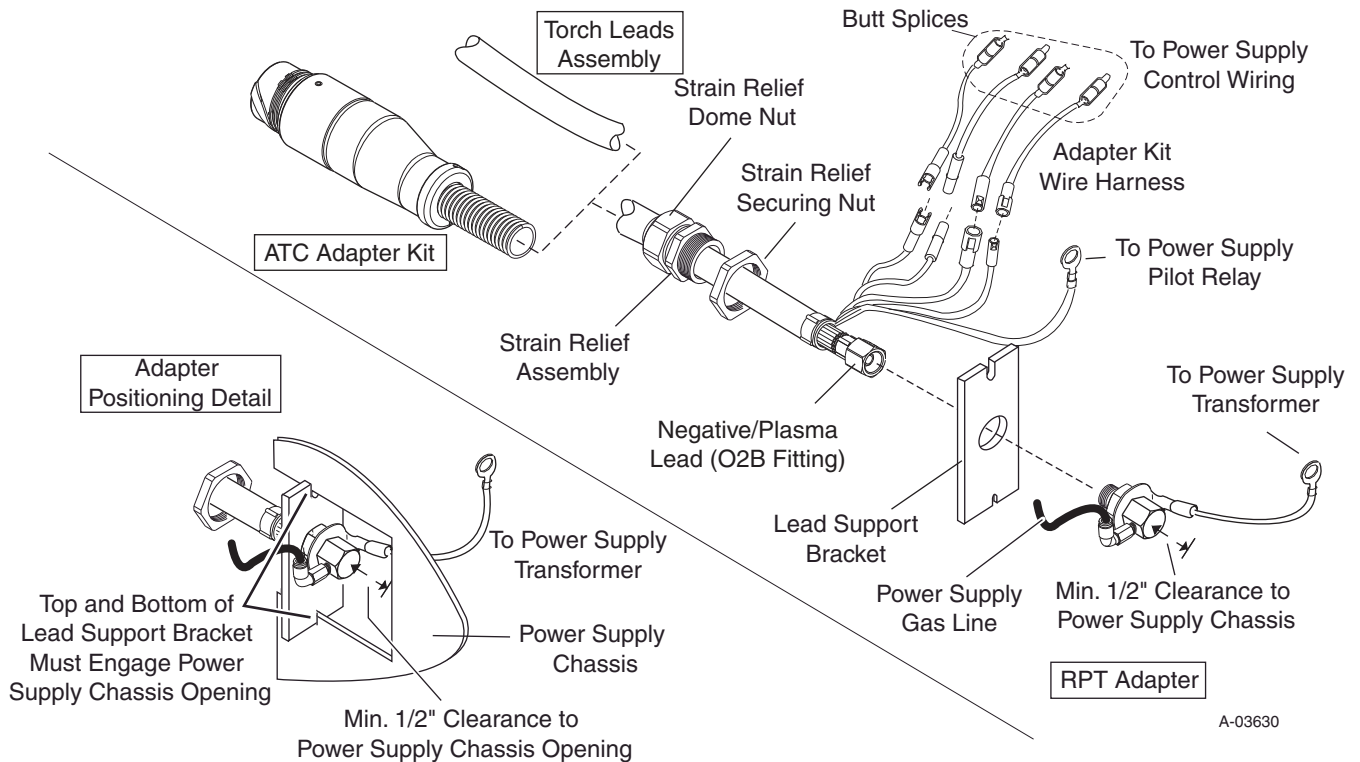

9. Connect the mating connectors on the control wire harness supplied in this kit to the connectors on the end of the torch leads or adapter leads.
10. Crimp the butt splices on the control wire harness to the blue and purple power supply wires cut when removing the original quick-disconnect fitting. Connect as follows:
 - Orange and black adapter harness wires to power supply blue wires.
 - White and green adapter harness wires to power supply purple wires.
11. Connect the red pilot wire (with ring terminal) on the torch or adapter leads to the bottom left terminal on the power supply pilot relay. Use the washer included in this kit under the head of the securing bolt.
12. Test-position the power supply gas line to the adapter elbow fitting. Shorten gas line as needed. Connect the power supply gas line to the adapter fitting. Push in on the end of the fitting, press the hose fully into the fitting, and release the fitting. Check for a secure fit.
13. Position the torch or adapter leads so that there is at least one-half inch clearance between the adapter fitting and the opening in the power supply chassis. Position the adapter fitting so that the gas line connection and the stem of the ring terminal leading to the power supply transformer are horizontal.
14. Tighten the strain relief dome nut onto the strain relief to secure the leads and adapter assembly in position. Tighten securely. Test for a secure fit.
15. Reinstall the power supply cover.
16. Check the torch for proper consumables per the torch instruction manual.
17. Reconnect primary input power and the gas supply.
18. Turn on the power supply. Set gas pressure per the torch instruction manual.

NOTE

Every effort has been made to provide complete and accurate information in this manual. However, the publisher does not assume and hereby disclaims any liability to any party for any loss or damage caused by errors or omissions in this Manual, whether such errors result from negligence, accident, or any other cause.

General Information

These instructions cover Thermal Dynamics No. 7-3483 Replacement Torch Adapter Kit. This kit connects Thermal Dynamics SL60 or SL100 Torch leads with O2B fittings, or the Thermal Dynamics ATC Adapter Kit, to Hypertherm* powermax* 1650 power supplies. Do not use this kit with any other equipment. Read these instructions before starting the replacement procedure. Keep these instructions for future reference.

CAUTION

Only a qualified technician should perform this procedure.

Parts Supplied

The kit includes:

- RPT Adapter Kit
- Wire Harness with Connector
- Strain Relief Assembly
- Strain Relief Extender
- Instructions

Procedure



WARNING

Disconnect primary input power at the source before starting this procedure.

1. Disconnect primary input power at the source. Disconnect gas input and bleed down the system.
2. Remove any parts for the original torch from the power supply spare parts compartment.
3. Remove the power supply cover per the power supply manufacturer's instructions.

4. Disconnect and remove the torch per the power supply manufacturer's instructions.
5. Slide back the insulating sleeve covering the wire terminated with a ring terminal on the ATC Adapter or torch leads assembly. Cut the ring terminal off the wire. Strip back the insulation on the wire approximately 1/4" / 6 mm from the end. Leave the insulating sleeve in place.
6. Remove and discard the tie wrap and insulating sleeve covering two joined connectors on the ATC Adapter Kit or torch leads. Disconnect the joined connectors.
7. Remove the securing nut from the Strain Relief Assembly supplied in this kit.
8. Thread the Strain Relief onto the Strain Relief Extender by hand.
9. Slide the Strain Relief and Extender onto the ATC Adapter Leads or Torch Leads.
10. Press the multi-pin connector on the wire harness from this kit securely into the wire receptacle just above the quick-release collar inside the power supply. Check for a secure connection.
11. Refer to the illustration. Pull back the quick-release collar on the Power Supply gas manifold. Insert the black plastic adapter fitting included in this kit. Release the quick-release collar to secure the fitting. Check for a secure fit.

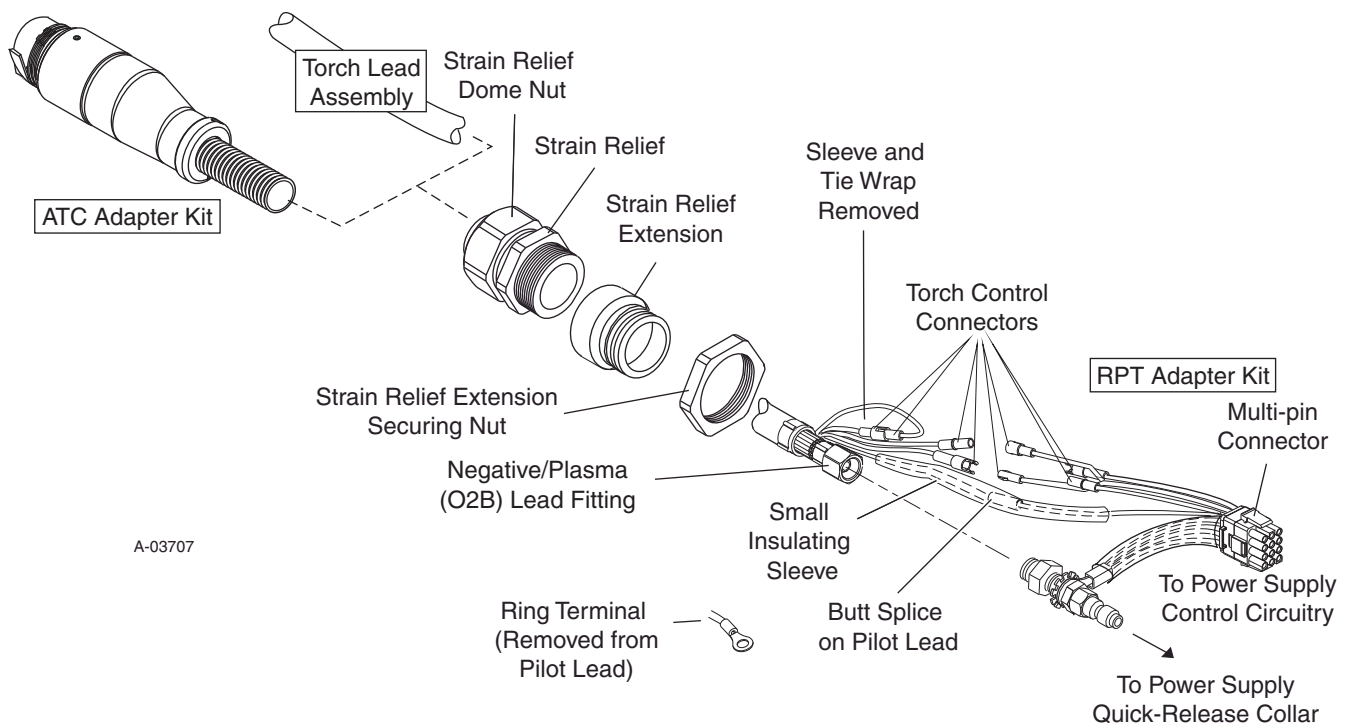

12. If not already done, place the ring tongue onto the brass adapter fitting included in this kit, as shown in the illustration. Fit the ring tongue onto the brass fitting. Loosely thread the small brass nut onto the brass fitting.
13. Pass the ATC Adapter or torch leads, with Strain Relief and Extender, through the front access opening in the power supply. Inside the power supply, slide the securing nut over the wire connectors on the end of the ATC Adapter or torch leads.
14. Use a tool to hold the securing nut stationary. Tighten the Strain Relief and Extender onto the nut. Do not tighten the Strain Relief Dome Nut onto the Strain Relief.

15. Securely crimp the butt splice on the Adapter Kit wire harness to the ATC Adapter or torch leads pilot wire. Check for a secure connection. Slide the insulating sleeve over the butt splice. Connect the torch control connectors on the ATC Adapter Kit or Torch Leads to the RPT Adapter Kit wire harness.
16. Use a tool to hold the Adapter Kit brass fitting stationary. Thread the ATC Adapter or torch leads O2B fitting onto the Adapter kit brass fitting securely. No sealant is required.
17. Use a tool to hold the Adapter Kit brass fitting stationary. Thread the small nut previously installed on the fitting securely against the ring tongue and star washer installed previously.
18. Tighten the Strain Relief Dome Nut onto the Strain Relief. Check for a secure connection.
19. In installations using the ATC Adapter, align and connect the torch leads male connector to the ATC Adapter female receptacle. The connectors should push together with a very small amount of pressure. Secure the connection by turning the locking nut clockwise until it stops. DO NOT use the locking nut to pull the connection together. Do not use tools to secure the connections.

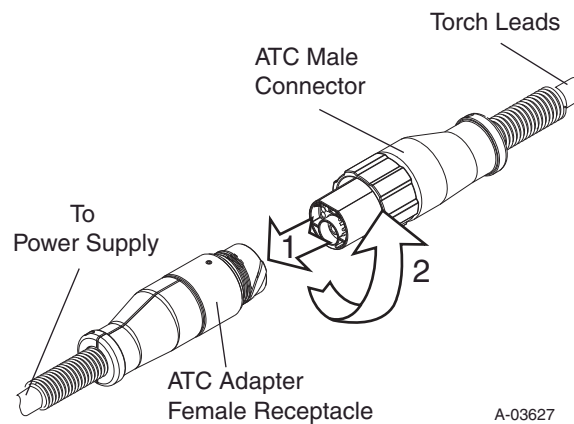

A-03627

Torch Connection - Torch Leads with ATC Male Connector, Power Supply with ATC Adapter

21. Check the torch for proper consumable parts.

■ CAUTION

The torch parts must correspond with the type of operation. Refer to the Torch Manual for details.

22. Reinstall the Power Supply cover per the power supply maker's instructions.
23. Reconnect the power supply to primary input power and gas supply.
24. Turn on the power supply. Set gas pressure per the torch manual. Set output current for the operation to be performed.
25. Test the torch for proper operation.

Pinout Diagram for RPT Hand Torch with ATC Adapter

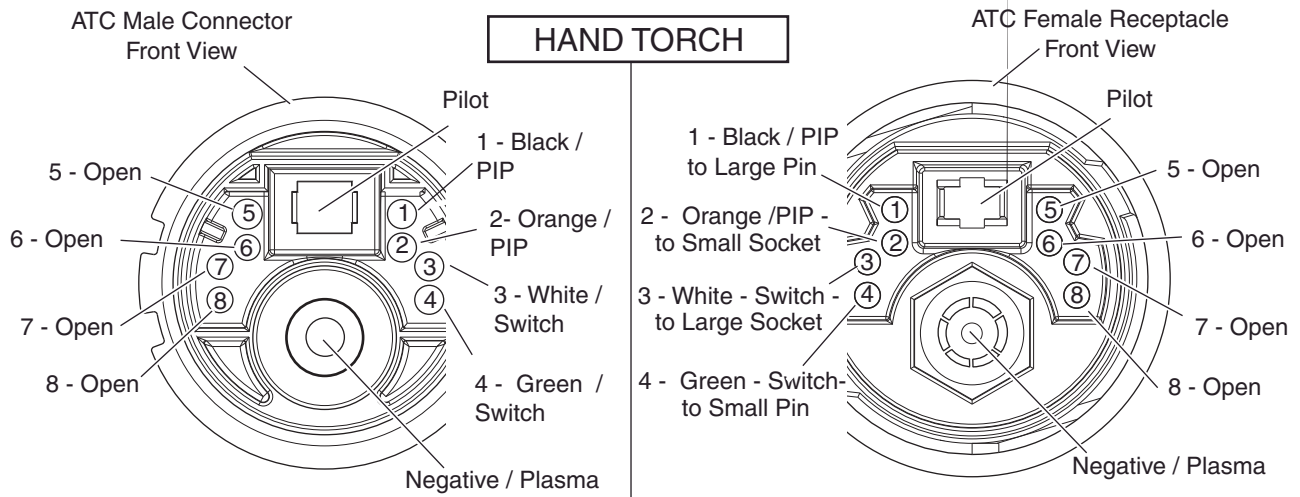

A-03708

NOTE

Every effort has been made to provide complete and accurate information in this manual. However, the publisher does not assume and hereby disclaims any liability to any party for any loss or damage caused by errors or omissions in this Manual, whether such errors result from negligence, accident, or any other cause.

General Information

This kit connects Thermal Dynamics 1Torch Adapters or SL60 / SL100 Torch leads to Hypertherm* powermax* 350 Power Supplies. Do not use this kit with any other equipment. Read these instructions before starting the installation procedure. Keep these instructions for future reference.

CAUTION

Only a qualified technician should perform this procedure.

Parts Supplied

The kit includes:

- RPT Adapter Assembly
- Adapter Fitting
- Four - Wire Harness with Connectors
- Butt Splice
- Insulating Sleeves (2)
- Tie Wraps (2)
- Strain Relief Assembly
- Instructions

Procedure

**WARNING**

Disconnect primary input power at the source and bleed down the system before starting this procedure.

1. Remove the power supply cover per the power supply manufacturer's instructions.
2. Disconnect the original torch (including the wire harness connected to the printed circuit board mounted vertically on the back side of the power supply front panel) per the power supply manufacturer's instructions. Remove the torch, the torch leads, and the strain relief from the power supply. Store any torch replacement parts with the original torch.
3. Disconnect the gas hose from the inlet side of the power supply solenoid. Push in on the fitting to release the hose, and pull the hose straight out.
4. Disconnect two 'Faston' connectors from the power supply solenoid.
5. Remove two screws securing the power supply solenoid assembly to the vertical support bracket. Lift the solenoid assembly out of the power supply.
6. Hold the solenoid assembly securely. Remove the brass fitting from the solenoid outlet port.

7. Install the black plastic Adapter Fitting included in this kit in the solenoid outlet port. Do not tighten yet.
8. Refer to the illustration. Position the RPT Adapter assembly as shown. Connect the RPT Adapter assembly to the black plastic fitting previously installed in the power supply solenoid. Do not overtighten. Do not use sealant.
9. Reinstall the solenoid assembly in the power supply. Secure the assembly with the screws removed previously. Tighten securely. Reconnect the two Faston connectors disconnected previously.
10. Reconnect the gas hose to the solenoid inlet port. Press the hose fully into the fitting. Check for a secure connection.
11. Inside the power supply, cut the 'faston' connector off power supply wire #25. Strip back the insulation on the wire approximately 1/4" / 6 mm from the end.
12. Slide back the insulating sleeve covering the pilot lead (terminated with a ring terminal) on the ATC Adapter or torch leads assembly. Cut the ring terminal off the lead. Strip back the insulation on the wire approximately 1/4" / 6 mm from the end. Securely crimp one end of the butt splice included in this kit to the end of the wire.
13. Remove the tie wrap and insulating sleeve covering two joined wires on the ATC adapter or torch leads assembly. Disconnect the wires.
14. Remove the securing nut from the strain relief assembly included in this kit. Slide the strain relief assembly onto the ATC Adapter Leads or torch leads assembly.
15. Refer to the illustration. Pass the end of the ATC Adapter Leads or torch leads assembly through the torch access opening in the front panel of the power supply.

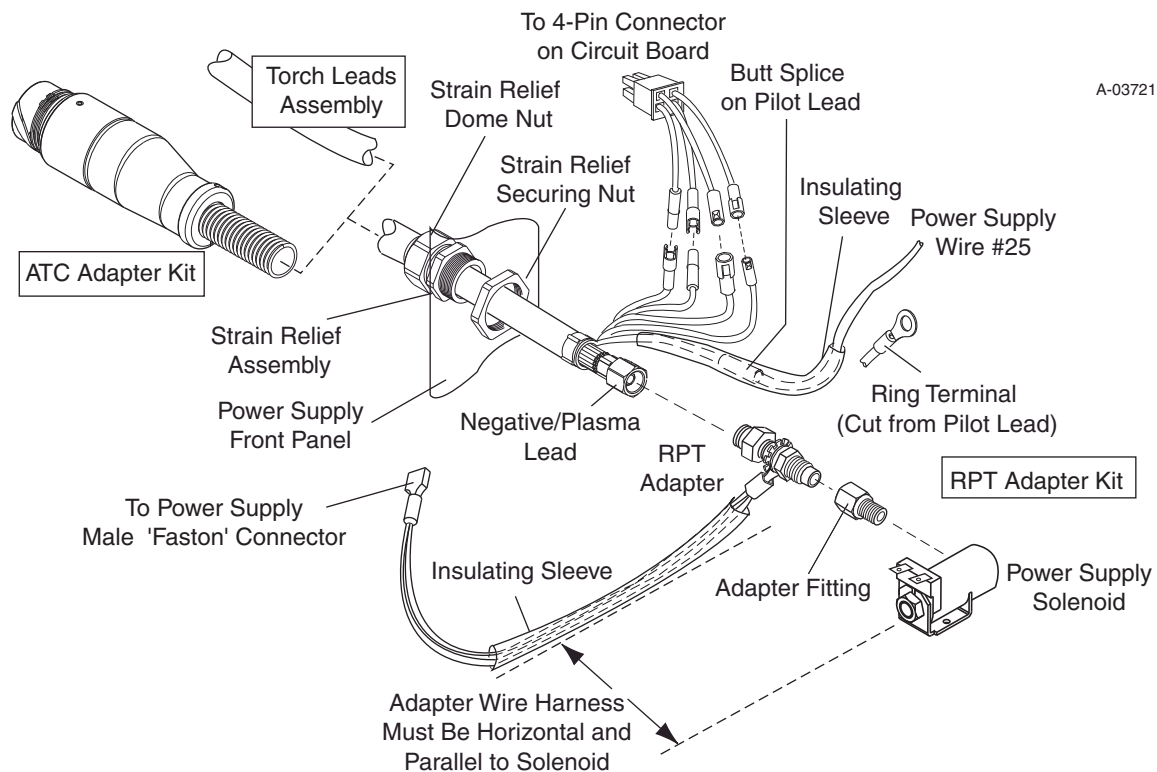

A-03721

16. Slide the strain relief securing nut onto the ATC Adapter Leads or torch leads assembly. Thread the nut onto the strain relief securely. Do not tighten the strain relief onto the torch leads.
17. Inside the power supply, loosely connect the negative/plasma lead fitting on the ATC Adapter or torch leads assembly to the RPT Adapter. Hold the Adapter assembly stationary with a tool grasping the narrow hex nut. Use another tool to turn the ATC Adapter or torch leads negative / plasma lead onto the adapter assembly. The adapter includes a pair of wires with an insulated 'faston' connector on the ends. This wire assembly must be in a horizontal position, leading from the adapter assembly toward the outside of the power supply, and parallel to the solenoid assembly.

CAUTION

This positioning is important for proper power supply and torch operation.

18. Slide one of the insulating sleeves included in this kit onto the ATC Adapter kit or torch leads pilot lead (with the butt splice). Crimp power supply wire #25 into the butt splice. Check for a secure connection. Slide the insulating sleeve along the wire to cover the butt splice. Secure the sleeve in place with one of the wire ties included in this kit.
19. Slide the second insulating sleeve included in this kit onto the RPT Adapter wires with the insulated 'faston' connector. Connect this connector to the power supply 'faston' connector previously disconnected from the original torch assembly. Slide the insulating sleeve along the wire to cover the 'faston' connector. Secure the sleeve in place with one of the wire ties included in this kit.
20. This adapter kit includes a wire harness assembly with a four - pin connector. Connect the mating connectors on this harness to the mating wire connectors on the ATC Adapter Assembly or torch leads assembly. Connect the four - pin connector to the power supply circuit board inside the power supply front panel.
21. Reinstall the power supply cover per the power supply manufacturer's instructions.

22. In installations with the ATC Adapter, connect the torch ATC male connector to the ATC Adapter receptacle. The connectors should push together with a very small amount of pressure. Secure the connection by turning the locking nut clockwise until it stops. **DO NOT** use the locking nut to pull the connection together.

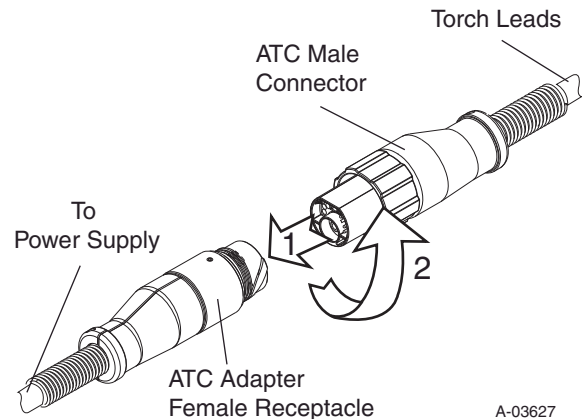

Torch Connection - Torch with ATC Male Connector, Power Supply with ATC Adapter

23. Check the torch for proper consumables per the torch manual.
24. Reconnect the power supply to primary input power and the gas supply.
25. Test the system for proper operation.

NOTE

Every effort has been made to provide complete and accurate information in this manual. However, the publisher does not assume and hereby disclaims any liability to any party for any loss or damage caused by errors or omissions in this Manual, whether such errors result from negligence, accident, or any other cause.

HERMAL DYNAMICS®

A THERMADYNE® Company

82 Benning Street, West Lebanon, NH 03784 USA
(603) 298-5711 • www.thermal-dynamics.com

RPT Adapter Kit No. 7-3485

Installation Instructions

General Information

This kit connects Thermal Dynamics 1Torch Adapters or SL60 / SL100 Torch leads to Hypertherm* powermax* 190C Power Supplies. Do not use this kit with any other equipment. Read these instructions before starting the installation procedure. Keep these instructions for future reference.

CAUTION

Only a qualified technician should perform this procedure.

Parts Supplied

The kit includes:

- Adapter Assembly
- Wire Harness with Connectors
- Gas Hose with Connector Fitting
- Hose Union
- 'Faston' Connector
- Insulating Sleeves (2)
- Tie Wraps (2)
- Strain Relief Assembly
- Instructions

Procedure



WARNING

Disconnect primary input power at the source and bleed down the system before starting this procedure.

1. Remove the power supply cover per the power supply manufacturer's instructions.
2. Remove wire ties as necessary to disconnect the torch leads from any other power supply components. Disconnect the original torch (including the pilot wire and wire harness and connector to the printed circuit board, and gas connection to the compressor outlet) per the power supply manufacturer's instructions. Remove the torch, the torch leads, and the strain relief from the power supply.
3. Slide back the insulating sleeve covering a wire terminated with a ring terminal on the ATC Adapter or torch leads assembly. Cut the ring terminal off the wire. Strip back the insulation on the wire approximately 1/4" / 6 mm from the end. Securely crimp the 'Faston' connector included in this kit to the end of the wire. Slide the insulating sleeve back down the wire to cover the base of the Faston connector.
4. Remove and discard the tie wrap and insulating sleeve covering two joined wires on the ATC adapter or torch leads assembly. Disconnect the wires.
5. Remove the securing nut from the strain relief assembly included in this kit. Slide the strain relief assembly onto the ATC Adapter Leads or torch leads assembly.

6. Refer to the illustration. Pass the end of the ATC Adapter Leads or torch leads assembly through the torch access opening in the front panel of the power supply.
7. Slide the strain relief securing nut onto the ATC Adapter Leads or torch leads assembly. Thread the nut onto the strain relief securely. Do not tighten the strain relief onto the torch or Adapter leads.
8. Slide one of the insulating sleeves included in this kit onto the ATC Adapter leads or torch leads Negative / Plasma (Gas) lead (only), inside the power supply.
9. Inside the power supply, connect the negative / plasma lead fitting on the ATC Adapter or torch leads assembly to the RPT Adapter. Hold the Adapter assembly stationary with a tool grasping the narrow hex nut. Use another tool to turn the ATC Adapter or torch leads negative / plasma lead onto the adapter assembly. Do not over-tighten. Do not use sealant.
10. Thread the Adapter Fitting onto the RPT Adapter securely by hand. Do not over-tighten. Do not use sealant.
11. Attach the hose union included in this kit to the Adapter fitting. Simply press the union onto the Adapter Fitting until it seats securely.
12. Press the end of the Gas Hose into the hose union. Press the hose into the union until it seats securely.
13. Connect the gas hose to the power supply compressor outlet, using the fitting on the gas line. Tighten securely. Do not over-tighten. Do not use sealant.
14. This adapter includes a wire harness assembly with a four - pin connector. Join the connectors on this harness to the mating wire connectors on the ATC Adapter Assembly or torch leads assembly. Connect the four - pin connector to the power supply circuit board inside the power supply.
15. The adapter includes a harness consisting of two sleeved wires terminated with a 'Faston' terminal. Ensure that the insulating sleeve is in place on the wires. Connect the 'Faston' terminal to the power supply circuit board connector marked 'ELECT WHITE'.
16. Connect the ATC Adapter or torch leads pilot lead to the power supply printed circuit board terminal marked 'Pilot Red'.

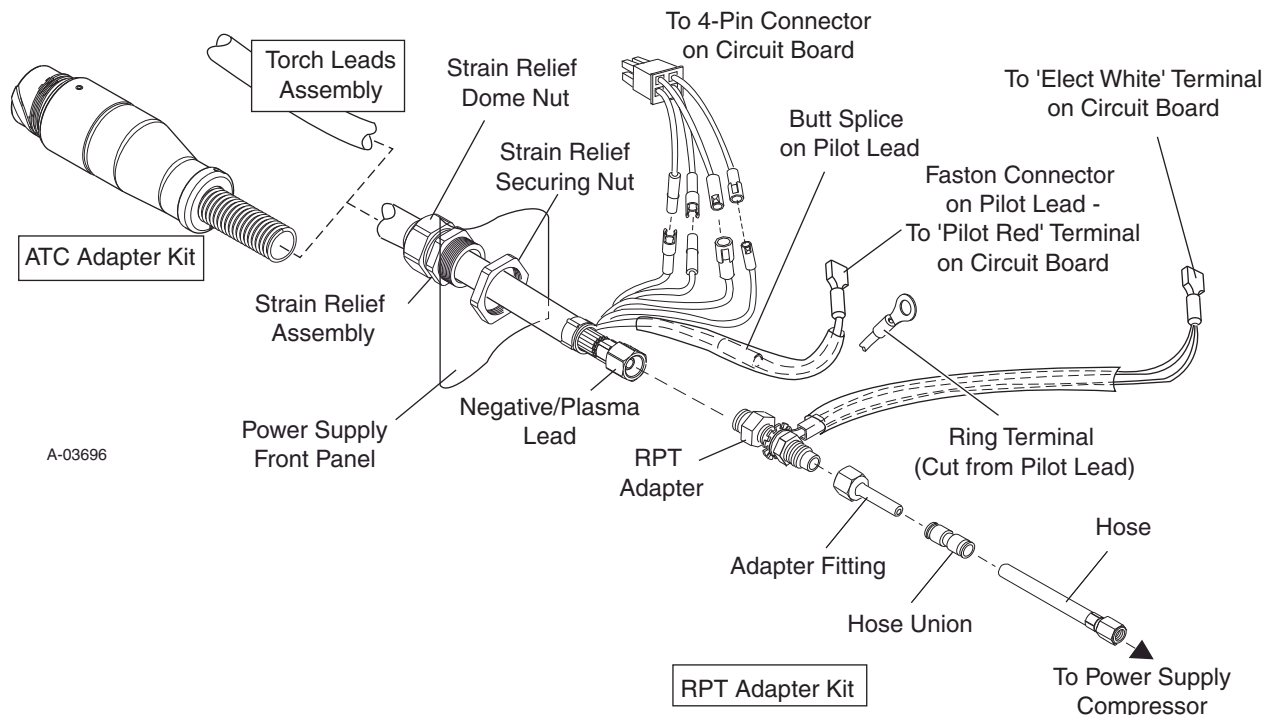

17. Tighten the strain relief dome nut onto the strain relief assembly. Check for a secure fit.
18. Use the wire ties included in this kit to secure the torch wire leads and work cable to the leads assembly
19. Reinstall the power supply cover per the power supply manufacturer's instructions.
20. In installations using the ATC Adapter, connect the torch ATC male connector to the ATC Adapter receptacle. The connectors should push together with a very small amount of pressure. Secure the connection by turning the locking nut clockwise until it stops. **DO NOT** use the locking nut to pull the connection together.

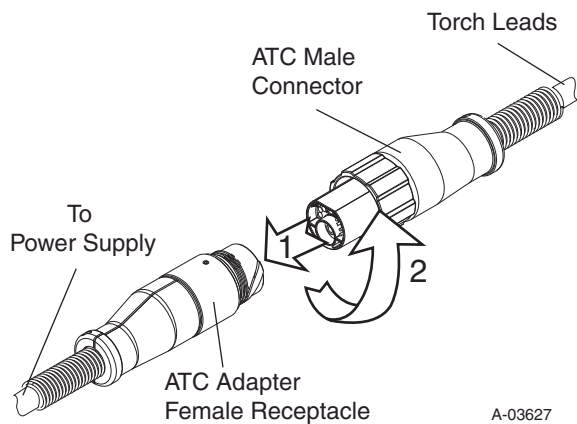

Torch Connection - Torch with ATC Male Connector, Power Supply with ATC Adapter

21. Check the torch for proper parts per the torch manual.
22. Connect the power supply to primary input power. Set gas pressure and flow per the torch manual.
23. Test the torch for proper operation.

NOTE

Every effort has been made to provide complete and accurate information in this manual. However, the publisher does not assume and hereby disclaims any liability to any party for any loss or damage caused by errors or omissions in this Manual, whether such errors result from negligence, accident, or any other cause.

Section III

ATC Lead Extensions/Adapters

Contents

7-5207

7-7544

7-7545

7-7552

7-3474

ATC Adapter Kit (Female Receptacle) Catalog # 7-5207

Installation Instructions

General Information

The ATC Adapter Kit (Female Receptacle) is used to connect the ATC Style RPT Torch to a plasma power supply. This kit is connected to a Torch Adapter Kit which is required to complete the installation.

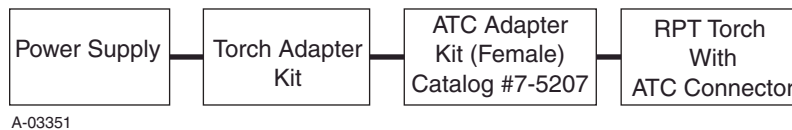

Typical ATC System Block Diagram

Parts Supplied

The following parts are included in this kit:

- ATC Adapter - 1 ea

Installation

Install the ATC Adapter Kit per the following procedure:

1. Turn OFF the power supply.
2. Disconnect the main input power to the power supply.
3. Remove the existing torch from the power supply, removing covers as required.
4. Install the Torch Adapter Kit, sold separately, for the type power supply, per instructions supplied with the Torch Adapter Kit.
5. For Power Supplies on which a Strain Relief was used on the existing Torch Lead, remove the old Strain Relief and install on the ATC Adapter per the following:
 - a. Remove the retaining nut from the Strain Relief.
 - b. Loosen the leads capture nut that secures the Strain Relief to the Torch Leads.
 - c. Remove the Strain Relief from the Torch Leads.
 - d. Install the Strain Relief onto the ATC Adapter Lead.
6. Feed the ATC Adapter Lead ends and the Strain Relief into the hole in the unit.
7. Secure the Strain Relief to the Power Supply with the retaining nut removed earlier, see WARNING.

NOTE

For Mechanized Systems refer to the Torch Control Cable Wiring Diagrams in the Manual supplied with the RPT Torch.

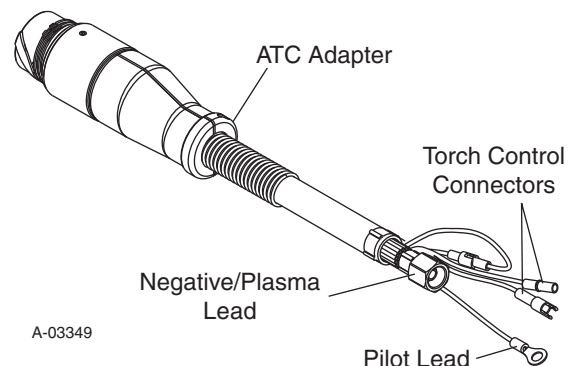

WARNING

If a Strain Relief is not used on the ATC Adapter, then the panel hole where the ATC Adapter enters the power supply should be adequately protected to prevent damage of the ATC Adapter Lead caused by rubbing on the edge of the hole.

8. Connect the ATC Adapter lead connections to the Torch Adapter Kit parts installed onto the Power Supply as described in the instructions supplied with the Torch Adapter Kit.
9. Tighten the Strain Relief onto the ATC Adapter Leads.
10. Connect the RPT Torch ATC connector to the ATC Adapter connection. The connectors should push together with a very small amount of pressure. Secure the connection by turning the locking nut clockwise until it stops. **DO NOT** use the locking nut to pull the connection together.
11. Reinstall any covers removed, see WARNING.
12. Install the proper torch consumables for the Power Supply amperage
13. Reconnect input power to the Power Supply and turn ON the unit.
14. Set proper gas pressure or flow.
15. Test torch for proper operation.



WARNING

*Make sure that the Control Connector Plug wires **DO NOT** contact the Adapter Fitting after all leads are connected.*

NOTE

Every effort has been made to provide complete and accurate information in this manual. However, the publisher does not assume and hereby disclaims any liability to any party for any loss or damage caused by errors or omissions in this manual, whether such errors result from negligence, accident or any other cause.

ATC Leads Extension Kits Catalog # 7-7544, 7-7545 & 7-7552

Installation Instructions

General Information

The ATC Leads Extension Kits are used to extend the total torch lead length of Thermal Dynamics Plasma RPT Torches using the ATC Style Connection. The ATC Leads Extensions are available in the following lengths:

- 15 ft / 4.6 m Length
- 25 ft / 7.6 m Length
- 50 ft / 15.2 m Length

Use of the ATC Leads Extension Kits is limited to the following restrictions:

- Can have no more than two ATC Leads Extensions in the total length.
- Total lead length, including torch leads, not to exceed 100 ft / 30.5 m, see NOTE.

NOTE

Total lead length must not exceed manufacturer's specified recommendations.

Parts Supplied

The following parts are included in this kit:

- ATC Leads Extension length as ordered - 1 ea

Installation

Install the ATC Leads Extension Kit per the following procedure:

1. Turn OFF the power supply.
2. Disconnect the main input power to the power supply.

3. Disconnect the torch from the ATC Adapter Kit connector, see NOTE, installed on the power supply.

NOTE

To use the ATC Leads Extension Kit, ATC Adapter Kit #7-5207 must be installed.

4. Connect the mating end of the ATC Leads Extension to the ATC Adapter Kit at the power supply.

If a second ATC Leads Extension is to be installed, make the connection to the first one installed.

5. Install the torch to the end of the ATC Leads Extension.
6. Reconnect input power to the Power Supply and turn ON the unit.
7. The system is ready for operation, see WARNING.



WARNING

Turn OFF the power supply when connecting or disconnecting the ATC connections.

NOTE

Every effort has been made to provide complete and accurate information in this manual. However, the publisher does not assume and hereby disclaims any liability to any party for any loss or damage caused by errors or omissions in this manual, whether such errors result from negligence, accident or any other cause.

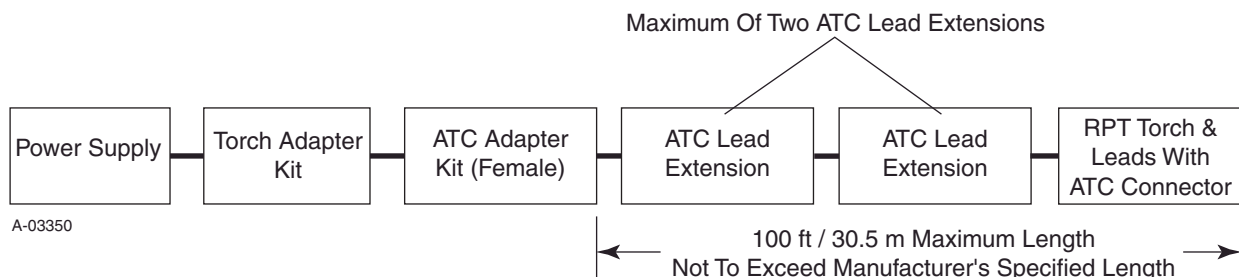

ATC™ Remote Interface Adapter Catalog # 7-3474

Installation Instructions

General Information

These instructions cover the Thermal Dynamics ATC Remote Interface Adapter Kit No. 7-3474. This adapter is only for Thermal Dynamics torches or Lead Extensions with ATC torch connectors. The adapter provides a simple connection for any remote control device. This adapter can be installed anywhere between the torch leads ATC connector and the ATC receptacle at the power supply. This adapter is suitable for both Hand and Machine torches.

Supplied Parts

The kit includes:

- Adapter
- Instructions

Procedure



WARNING

Disconnect primary input power at the source before beginning the procedure.

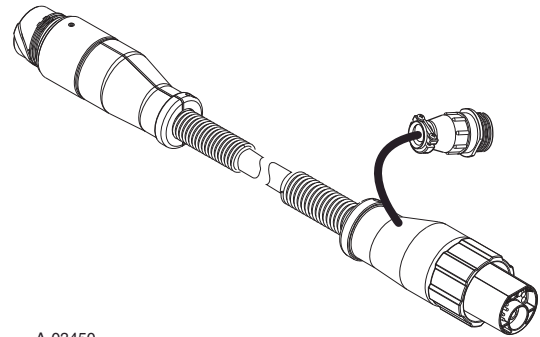

A-03450

A. Preparation

1. Disconnect the torch leads or torch leads extension ATC male connector, if installed, from the ATC female receptacle. Turn the locking ring to release the connector from the receptacle. Pull the connector straight out from the receptacle.
2. Connect the Thermal Dynamics Remote Pendant Control to the connector on the Remote Adapter Kit, or adapt other remote control devices to the Kit as required.

B. Installation

1. Align the male connector on the ATC Remote Interface Adapter with the ATC female receptacle. Press the connector into the receptacle. The connectors should push together with a small amount of pressure. Secure the connection by turning the locking nut clockwise until it stops. **DO NOT** use the locking nut to pull the connection together.
2. Align the male connector on the torch leads (or torch leads extension) with the female receptacle on the Adapter Kit. Press the connector into the receptacle. The connectors should push together with a small amount of pressure. Secure the connection by turning the locking nut clockwise until it stops. **DO NOT** use the locking nut to pull the connection together.

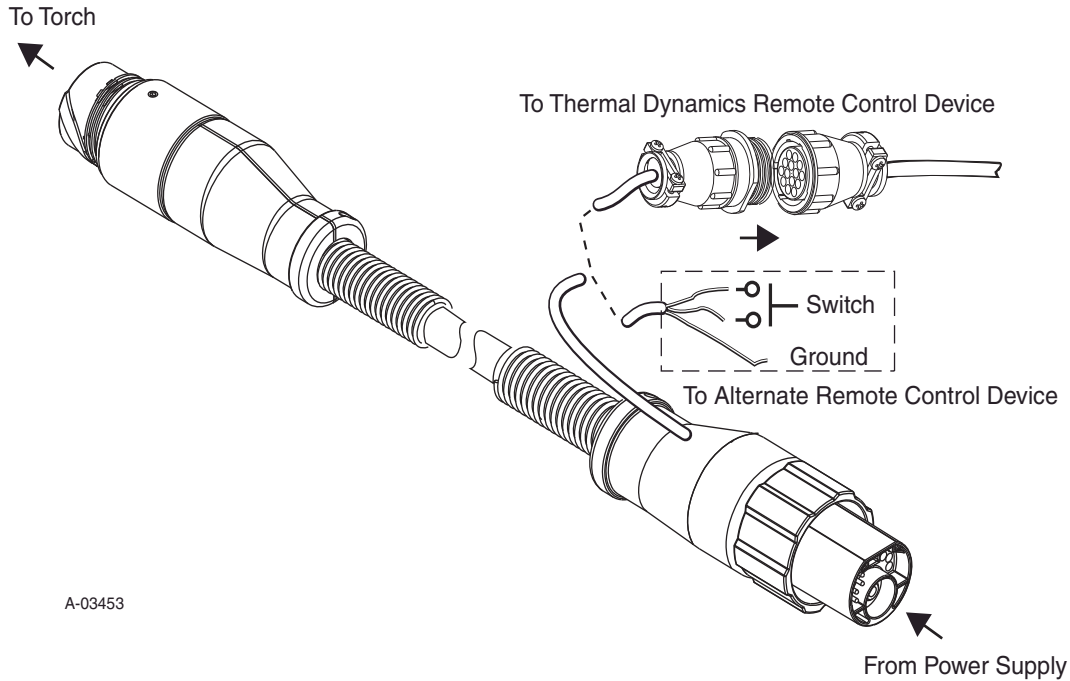

3. Reconnect input power to the Power Supply and turn ON the unit. The Remote Pendant Control will now provide on / off signals to the torch. Any other torch control switches will be inoperable with this Adapter in place. To make other control switches operable, remove the Adapter.
4. The system is ready for operation, see WARNING.



Turn OFF the power supply when connecting or disconnecting the ATC connections.

NOTE

Every effort has been made to provide complete and accurate information in this manual. However, the publisher does not assume and hereby disclaims any liability to any party for any loss or damage caused by errors or omissions in this Manual, whether such errors result from negligence, accident, or any other cause.

Section IV

Remote Interface Kits

Contents

7-3452

7-3470

**Remote Pendant Interface
 RPT Adapter Kit
 Catalog # 7-3452**

Installation Instructions

General Information

This kit allows any RPT Torch Adapter Kit to be interfaced with a Remote Pendant Control. The kit can be used with any Mechanized Torch System with unshielded leads.

Parts Supplied

The kit includes:

- Remote Pendant Adapter
- Jumper Assembly (for use with 2-wire leads assemblies only)
- Instructions

Installation

1. Turn OFF the power supply.
2. Disconnect main input power to the power supply.
3. Remove the existing torch and strain relief from the power supply, removing covers as required.

4. On the RPT Torch remove the Strain Relief Nut from the Strain Relief.
5. The Remote Pendant Adapter must be installed as follows (refer to illustrations):
 - a. Connect the Control Connector Plug (refer to NOTE) to the Power Supply.

NOTE

The Control Connector Plug is supplied in an additional RPT Torch Adapter Kit and is required to complete the installation to the Power Supply.

- b. Route the Remote Pendant Adapter connectors on the end of the adapter wiring through the Strain Relief Nut.
- c. Continue routing the adapter wiring through the hole in the front of the Power Supply.
- d. Feed the end of the torch lead and the Strain Relief into the access hole in the power supply.
- e. Route the wires of the adapter into the notch of the Strain Relief.
- f. Tighten the Strain Relief Nut to secure the Strain Relief to the Power Supply.

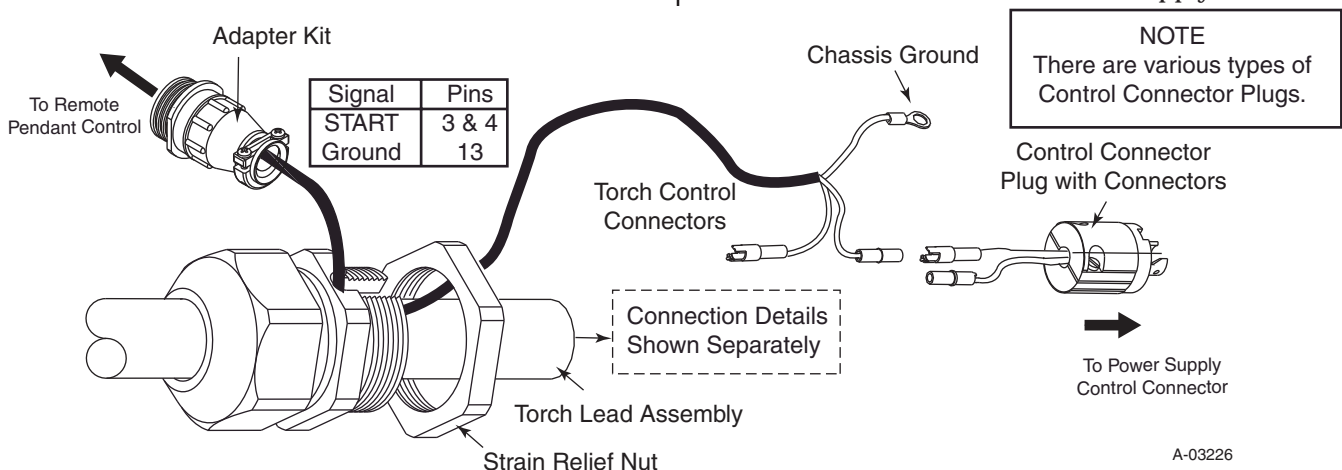

A-03226

6. Connect the pilot lead (+) from the replacement torch to the Power Supply and tighten securely.
7. Connect the Negative / Plasma Lead from the replacement torch to the Power Supply. Slide the protective boot over the lead connection.
8. Connect the Control Connector Plug as follows:
 - a. Connect one connector to the mating Torch Control Circuit Connector on the torch leads.
 - b. **For four-wire Torch & Lead Assemblies:**
Remove the insulating sleeve covering two joined Torch & Lead wires. Connect the Torch & Lead wires to the Control Connector and Remote Pendant Adapter wires as follows:

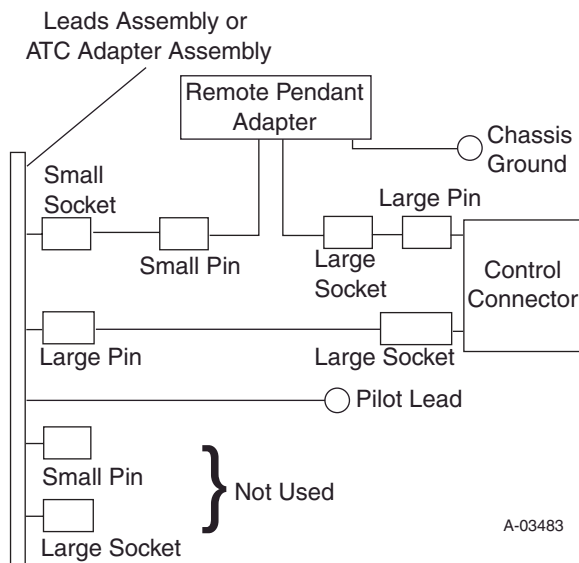

- c. The torch or ATC Adapter wires with the large socket connector and the small pin connector will not be used in this application. Cut the insulating sleeve removed previously in half. Install one half on each unused connector; secure in place with electrical tape.

c. **For two-wire Torch & Lead Assemblies:**

Connect the Torch & Lead wires to the Control Connector and Remote Pendant Adapter wires as follows:

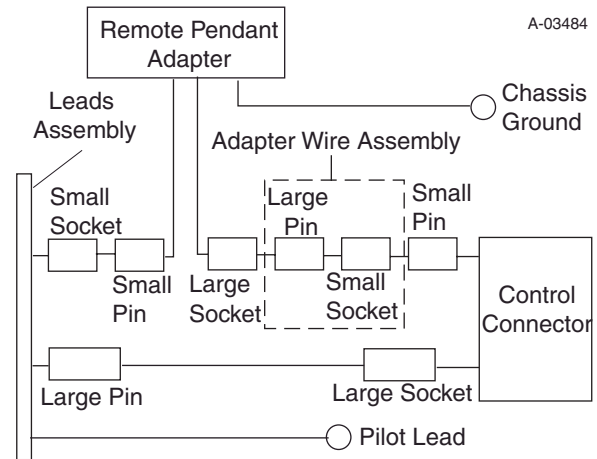

9. Tighten the Strain Relief onto the Torch Leads.
10. This kit includes a 14-circuit adapter receptacle. Use this receptacle if required to connect this Adapter Kit to the Remote Pendant Control.
11. Reinstall any covers removed.
12. Install the proper torch consumables for the Power Supply amperage.
13. Reconnect main input power to the Power Supply and turn the unit ON.
14. Set air pressure and flow according to the Torch Manual or Power Supply Manual.
15. Test torch for proper operation.

NOTE

Every effort has been made to provide complete and accurate information in this manual. However, the publisher does not assume and hereby disclaims any liability to any party for any loss or damage caused by errors or omissions in this manual, whether such errors result from negligence, accident or any other cause.

General Information

This kit connects a Thermal Dynamics Remote Pendant to SL60 or SL100 Torches equipped with the ATC connector.

Supplied Parts

The kit includes:

- Adapter Fitting
- Wire Assembly
- Wire Nut
- Instructions



WARNING

Disconnect primary input power to the system before starting the installation.

Shut off input gas supply and bleed down the system.

Only a qualified technician should perform this procedure.

Installation Procedure

A. Preparation

1. Disconnect the ATC male connector from the female receptacle.
2. **For shielded leads only:**
 - a. Remove the tie wrap securing the outer woven nylon leads cover to the ATC connector.
 - b. Slide back the insulating boot covering the leads assembly and extending partway over the ATC connector.
 - c. Remove the metal tie wrap securing the wire mesh leads shield to the ATC Connector. Slide the wire mesh leads shield off the ATC Connector.
3. Disassemble the ATC male connector as follows:
 - a. Remove 4 screws from the shell halves.
 - b. Separate and remove the shell halves.
4. One shell half includes a molded knockout. Remove the plastic material from this knockout. Smooth the edges of the knockout.

NOTE

The following sections differ between shielded and unshielded applications.

B. Installation on Unshielded ATC Connectors

1. Refer to the illustration. Unfold Torch Leads individual wires as needed for access to sockets in the ATC male connector. The Remote Pendant Adapter wire harness includes three wires terminated with pins. Insert the pins in sockets in the ATC male connector as follows:

- White wire in socket 3.
- Black wire in socket 4.
- Green wire in socket 8.

There should be an audible click when a pin seats fully in its socket. Installation may require a tool for access to the sockets.

2. Press the Adapter wire harness into the knockout in the shell half. The wire tie on the harness must be positioned inside the shell half.
3. Slide the locking ring into position on the male connector.
4. Position the wire bend relief on the Torch Lead.
5. Fit the shell halves against the male connector and wire bend relief. Align keys in grooves in the shell halves with notches in the male connector ring. Press the shell halves tightly together by hand. Ensure that the center assembly cannot rotate within the shell halves.
6. Fasten the shell halves together with the screws removed previously. Tighten the screws securely.

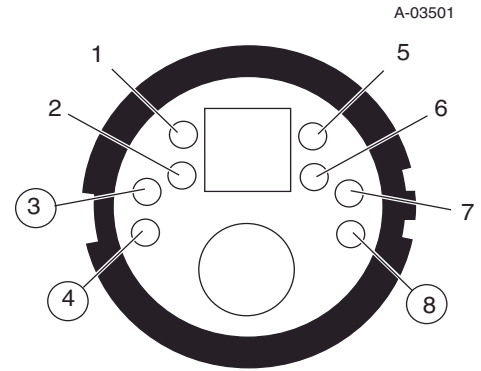

ATC Male Connector, Rear View

C. Ground Wire Installation on Unshielded ATC Connectors

This section applies only in applications with a remote pendant which requires grounding.

1. Disassemble the ATC female receptacle as follows:
 - a. Remove 4 screws from the shell halves.
 - b. Separate and remove the shell halves.
2. One shell half includes a molded knockout. Remove the plastic material from this knockout. Smooth the edges of the knockout.
3. This kit includes a length of grounding wire terminated with a socket at one end. Install the socket in position 8 on the female receptacle.
4. Pass the grounding wire through the knockout in the shell half.
5. Position the wire bend relief on the Torch Lead or Adapter Lead.
6. Fit the shell halves against the male connector and wire bend relief. Align pins in grooves in the shell halves with notches in the male connector ring. Press the shell halves tightly together by hand. Ensure that the center assembly cannot rotate within the shell halves.
7. Fasten the shell halves together with the screws removed previously. Tighten the screws securely.
8. Connect the grounding wire to the power supply chassis ground. Use the wire nut included in this kit if necessary.

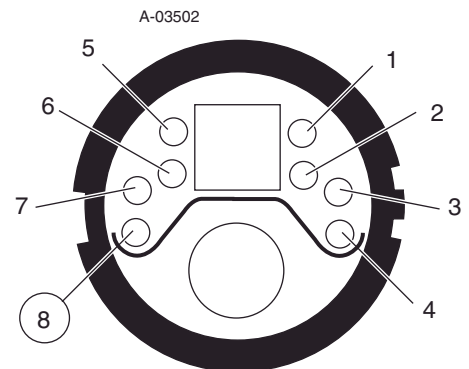

ATC Female Receptacle, Rear View

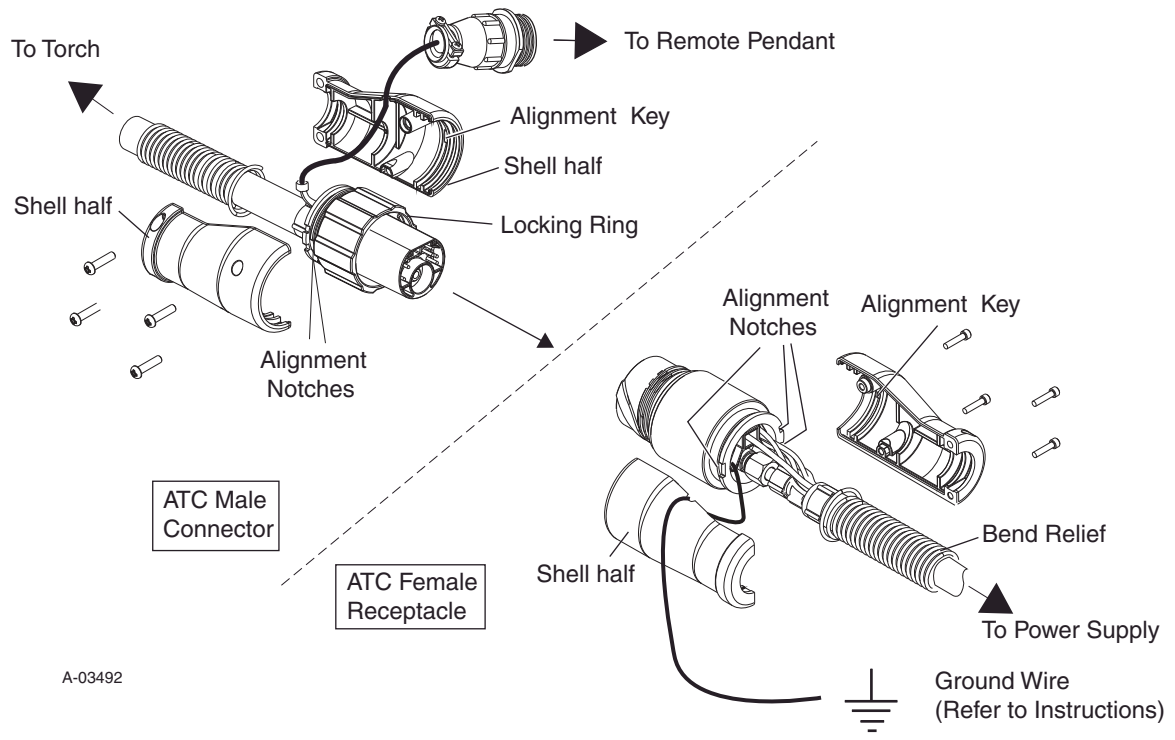

A-03492

Adapter Installation, Unshielded Leads

D. Installation on Shielded ATC Connectors

1. Refer to the illustration. Unfold individual wires in the ATC male connector as needed for access to sockets.
2. Cut the wire connected to the pin in socket #8 in the ATC male connector, 1.5 inch / 38 mm from the flange at the end of the male connector (inner) center assembly. Strip back the insulation jacket from each end of the wire approximately 3/8 inch / 9.5 mm from the ends of the wires.
3. The Remote Pendant Adapter wire harness includes three wires terminated with pins. Cut the pin off the end of the green wire on the Adapter. Cut as close as possible to the pin. Strip the insulation jacket back 3/8 inch / 9.5 mm from the end of the wire.

4. Insert the pins on wires in the Remote Pendant Adapter wire harness into sockets in the ATC male connector as follows:

- White wire in socket 3.
- Black wire in socket 4.

There should be an audible click when a pin seats fully in its socket. Installation may require a tool for access to the sockets.

5. Use the wire connector included in this kit to connect the two ends of the wire cut in Step 2 to the green wire on the Remote Pendant Adapter wire harness. Crimp the wires together securely; test for a proper connection.
6. Position all wires to fit inside the ATC Connector shell halves. Press the Adapter wire harness into the knockout in one shell half. The wire tie on the harness must be positioned inside the shell half.
7. Slide the locking ring into position on the male connector.
8. Fit the shell halves against the male connector. Align keys in grooves in the shell halves with notches in the male connector ring. Press the shell halves tightly together by hand. Ensure that the center connector assembly cannot rotate within the shell halves. Ensure that the locking ring rotates freely.
9. Fasten the shell halves together with the screws removed previously. Ensure that no wires are caught between the edges of the shell halves. Tighten the screws securely.
10. Slide the black insulating boot down to cover the wire mesh shield on the torch leads. The forward end of the boot must be positioned far enough down the leads to enclose the back end of the ATC Connector shell halves. Use electrical tape to secure the back end (away from the ATC Connector) into position on the torch leads assembly.
11. Slide the end of the outer woven leads cover down over the back end of the ATC Connector. Secure the cover in place with a tie wrap.
12. Connect the torch and the remote pendant control per instructions provided with the individual components. Test the system for proper operation.

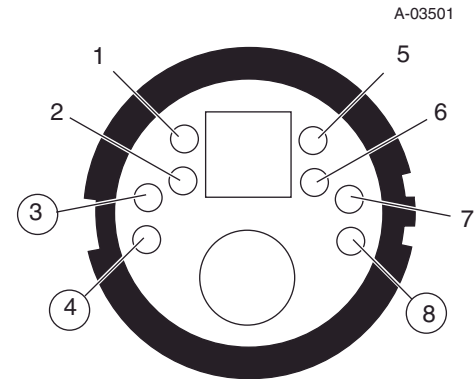

ATC Male Connector, Rear View

NOTE

Every effort has been made to provide complete and accurate information in this manual. However, the publisher does not assume and hereby disclaims any liability to any party for any loss or damage caused by errors or omissions in this Manual, whether such errors result from negligence, accident, or any other cause.

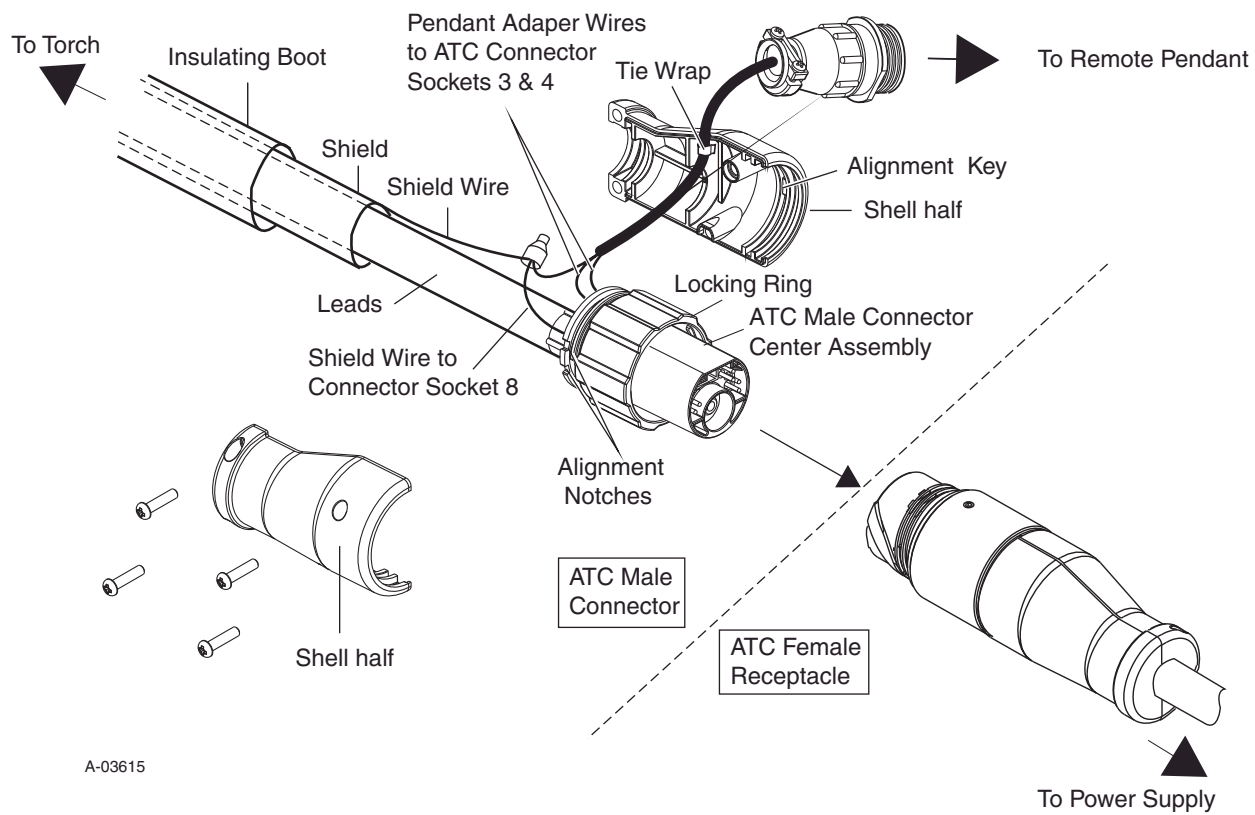

A-03615

Adapter Installation, Shielded Leads

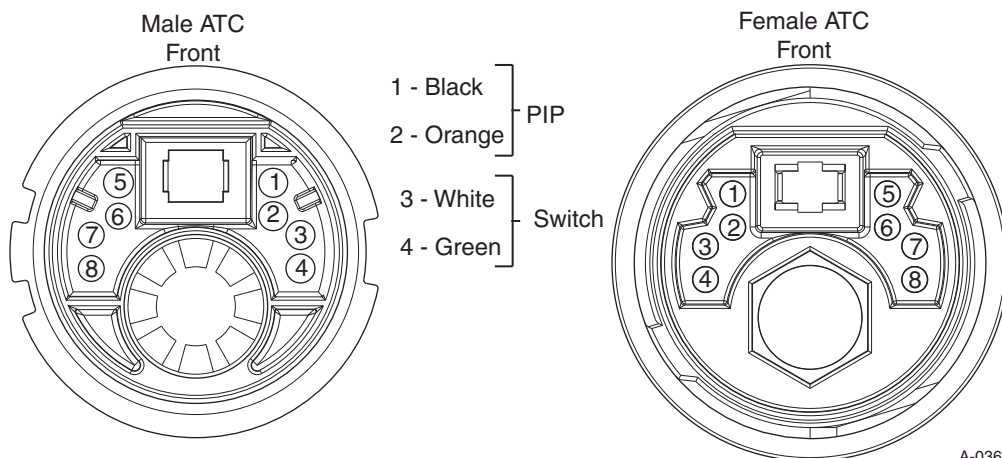

A-03614

Section V

Replacement Kits

Contents

9-7030

9-7031

9-7034

9-8218

A THERMADYNE® Company

82 Benning Street, West Lebanon, NH 03784 USA
(603) 298-5711 • www.thermal-dynamics.com

**Torch Handle Replacement Kit
for SL60 & SL100 Hand Torches
Catalog No. 9-7030**

Installation Instructions

General Information

These instructions cover the Torch Handle Replacement Kit No. 9-7030 for Thermal Dynamics Model SL60 and SL100 Plasma Cutting Hand Torches.

The replacement should only be performed by a qualified technician. Read the instructions thoroughly first, before attempting the replacement procedure.

Supplied Parts

The kit includes:

- Left and Right Handle Halves - 1
- Trigger and Trigger Release Assembly - 1
- Trigger Return Spring - 1
- Handle Screws - 5
- Handle Screw Wrench - 1
- Torch Handle Labels - (1) SL60, (1) SL100
- Installation Instructions - 1

Replacement Procedure



WARNING

Disconnect primary input power at the source before disassembling the Torch.

A. Preparation

1. This kit includes two sets of torch handle labels. Choose the appropriate labels (SL60 or SL100) and apply them to the recesses in the handle halves. The labels are important for future identification of the torch model. Discard the unused label.

B. Disassembly

Disassemble the torch as follows:

1. Remove the consumables (shield cup, tip, starter cartridge, and electrode) from the torch head. Remove 5 handle screws as illustrated.
2. Lift the left handle half off the assembly and set aside.
3. Lift the Trigger and Trigger release Assembly out of the right handle half, and set aside.
4. Carefully lift the torch head and leads assembly out of the right handle half.
5. Note the colors of the switch wires. Lift the switches off the mounting pins.

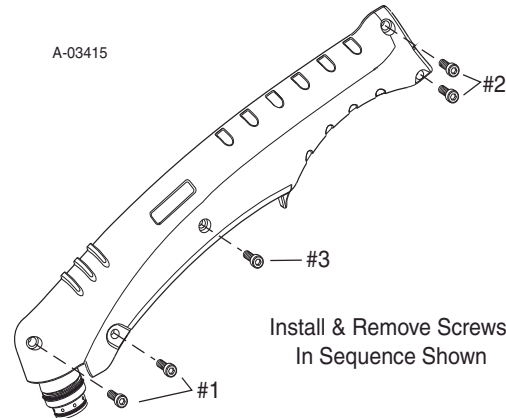

C. Reassembly

1. Position the replacement right handle half as shown in the illustration.
2. Check the colors of the switch wires. Position the switches in the same arrangement as the original placement. Position the switches carefully on the mounting pins, with the activating blades oriented the same way as the originals. Refer to the illustration.
3. Position the Torch Leads and Torch Head assembly in the right handle half. Sleeved splices on the torch switch leads fit into a recess in the right handle half.
4. The Trigger Assembly includes the Trigger Release, two Trigger Release return springs, and a Trigger return spring. Check the Assembly against the illustration. Ensure that the trigger release is fully against the trigger and slides freely along the trigger, and that the springs are in place.
5. Position the back end of the replacement Trigger Assembly in the replacement right handle half. The trigger return spring engages a socket on the upper (inner) surface of the trigger. Position the trigger pivot pin in a socket on the right handle half.
6. Refer to the illustration. Ensure that:
 - The pivot pin of the trigger engages the mating socket in the right handle half.
 - The activating blade of the torch switch fits in a slot on the back end of the torch trigger.
 - Wires do not impede the motion of the Trigger Assembly.
7. Position all wires to avoid pinching when the handle hardware is secured.
8. Position the left handle half against the right half. Adjust as needed to ensure that the pivot pin on the Trigger Assembly engages its mating socket in the left handle half. Hold the Torch Assembly together tightly by hand. Test the Trigger Assembly for proper operation.
9. Install and tighten all screws. Check to ensure that no wires are pinched between the edges of the handle halves when the screws are tightened fully.

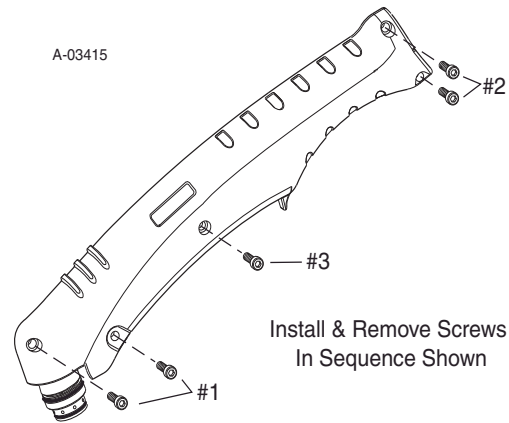

Replacing Handle Screws

10. Test the torch Trigger Assembly for proper operation.
11. Reinstall the consumables in the torch. Connect the Torch to the Power Supply. Test for proper operation.

NOTE

Every effort has been made to provide complete and accurate information in this manual. However, the publisher does not assume and hereby disclaims any liability to any party for any loss or damage caused by errors or omissions in this Manual, whether such errors result from negligence, accident, or any other cause.

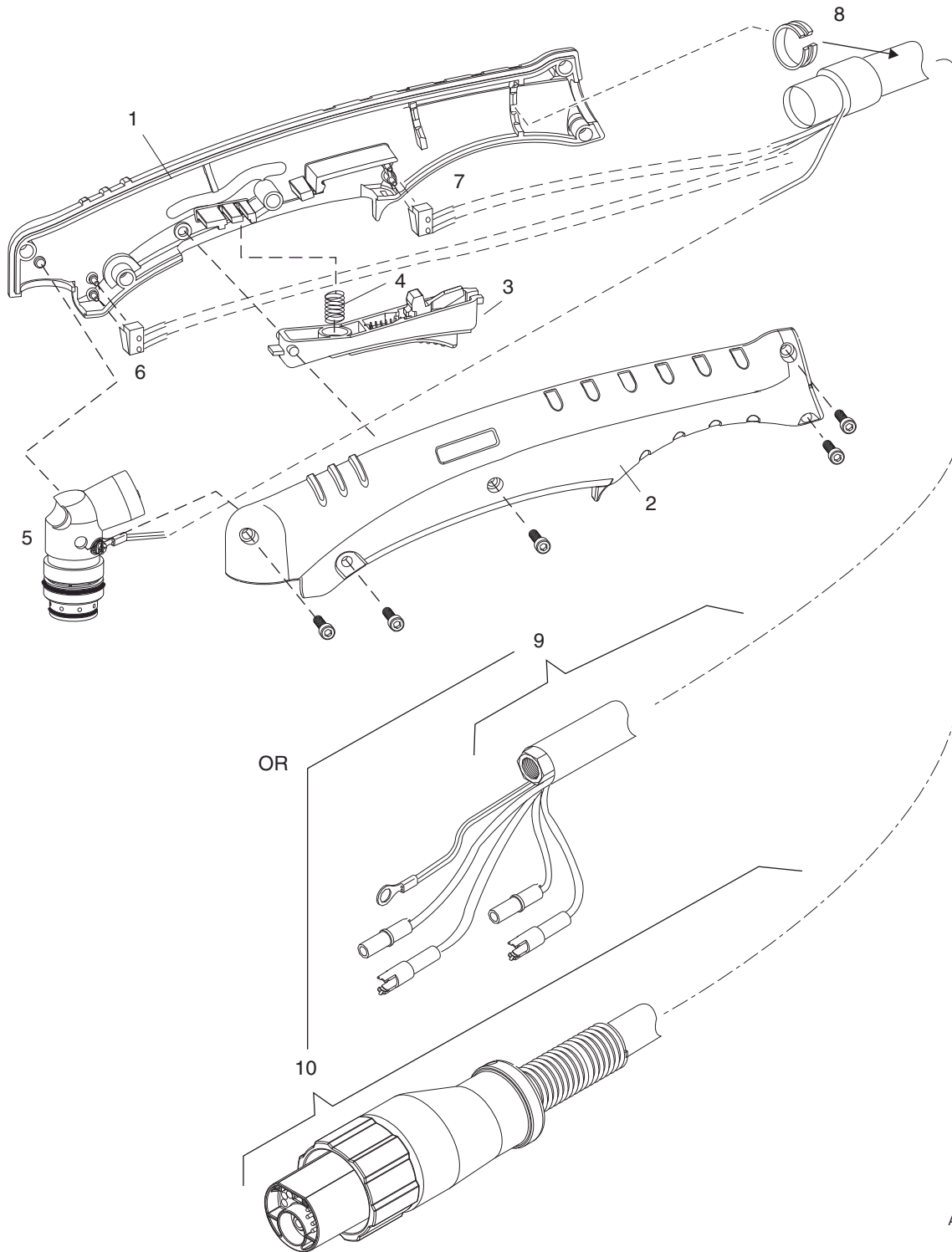

A-03431

- 1 Right Handle Half
- 2 PIP Switch
- 3 Torch Trigger Switch
- 4. Trigger Assembly
- 5 Trigger Return Spring

- 6 Left Handle Half
- 7 Torch Head
- 8 Pilot Lead Terminal
- 9 Internal Star Washer
- 10 Screw

- 11 Torch Lead Fitting
- 12 Handle Screw
- 13 Leads Connection (O2b)
- 14 Leads Connection (ATC)
- 15 Leads Bushing (SL60 only)

**Replacement Switch Kit
for SL60 & SL100 Torches
Catalog No. 9-7031**

Installation Instructions

General Information

These instructions cover Switch Replacement Kit No. 9-7031 for Thermal Dynamics Model SL60 and SL100 Plasma Cutting Torches.

This kit replaces either the Torch PIP Switch (just behind the torch head) or the Torch Trigger Switch (just behind the torch trigger assembly).

The replacement should only be performed by a qualified technician. Read the instructions thoroughly first, before attempting the replacement procedure.

Supplied Parts

The kit includes:

- Replacement Switch Assembly with leads - 1
- Butt Splices - 2
- Heat Shrink Tubing - 1
- Handle screw wrench - 1
- Installation Instructions - 1

Replacement Procedures



WARNING

Disconnect primary input power at the source before disassembling the Torch. Disconnect the leads from the Power Supply.

A. Torch Disassembly

Disassemble the torch as follows:

1. Remove 5 screws from the handle as illustrated.
2. Lift the left handle half and the trigger assembly off the right handle half and set aside.

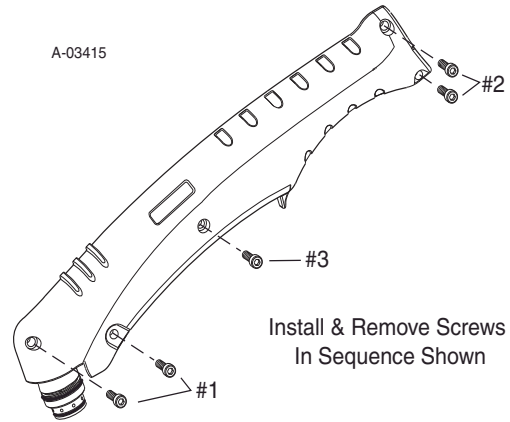

Removing Handle Screws

B. Replacing Torch Switch

1. Note the position of the switch activating blade.
2. Lift the switch directly up off its mounting pins.
3. Cut wires leading to the switch. Set the switch aside.

Cut the length of heat shrink tubing provided in this kit in half. Slide one piece of tubing onto each of the cut wires.

4. Use the butt splices provided to connect the torch leads wires to the replacement switch wires.

Slide the sections of heat shrink tubing over the butt splices. Use a heat gun to shrink the tubing over the butt splices.

5. Position the replacement switch carefully on the mounting pins, with the activating blade oriented the same way as the original. Refer to the illustration. The activating blade of the torch switch must fit between two protrusions on the back end of the torch trigger. The activating blade of the PIP switch must face up and forward, so that the shield cup will close the switch.

6. Check the Trigger Assembly against the illustration. Ensure that the trigger release is fully against the trigger and slides freely along the trigger, and that the springs are in place.
7. Position the replacement Trigger Assembly in the right handle half. Install the back end of the Assembly first. The notch in the back end of the Trigger must capture the actuator tab on the torch switch. The trigger return spring must engage a socket on the upper (inner) surface of the trigger. Ensure that the trigger closes the torch switch when the trigger release is slid fully to the rear and the trigger is pressed.
8. Refer to the illustration. Ensure that the pivot pin of the trigger engages the mating socket in the handle half.

C. Torch Reassembly

Complete the reassembly as follows:

1. Position all wires to avoid pinching when the handle hardware is secured.
2. Position the left handle half against the right half. Adjust as needed to ensure that the pivot pin on the Trigger Assembly engages its mating socket in the left handle half. Hold the Torch Assembly together tightly by hand.
3. Install and tighten all screws. Follow the sequence illustrated. Check to ensure that no wires are pinched between the handle halves when the screws are tightened fully.

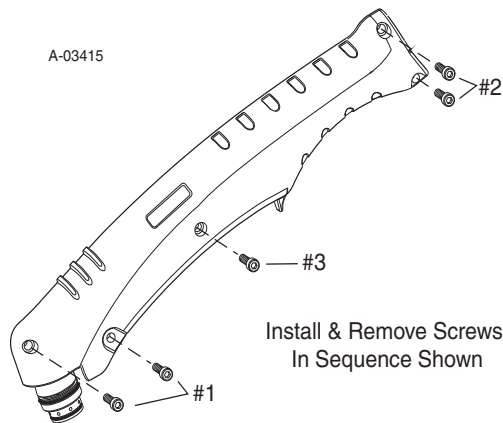

Replacing Handle Screws

4. Reconnect the Torch to the Power Supply. Test for proper operation.

NOTE

Every effort has been made to provide complete and accurate information in this manual. However, the publisher does not assume and hereby disclaims any liability to any party for any loss or damage caused by errors or omissions in this Manual, whether such errors result from negligence, accident, or any other cause.

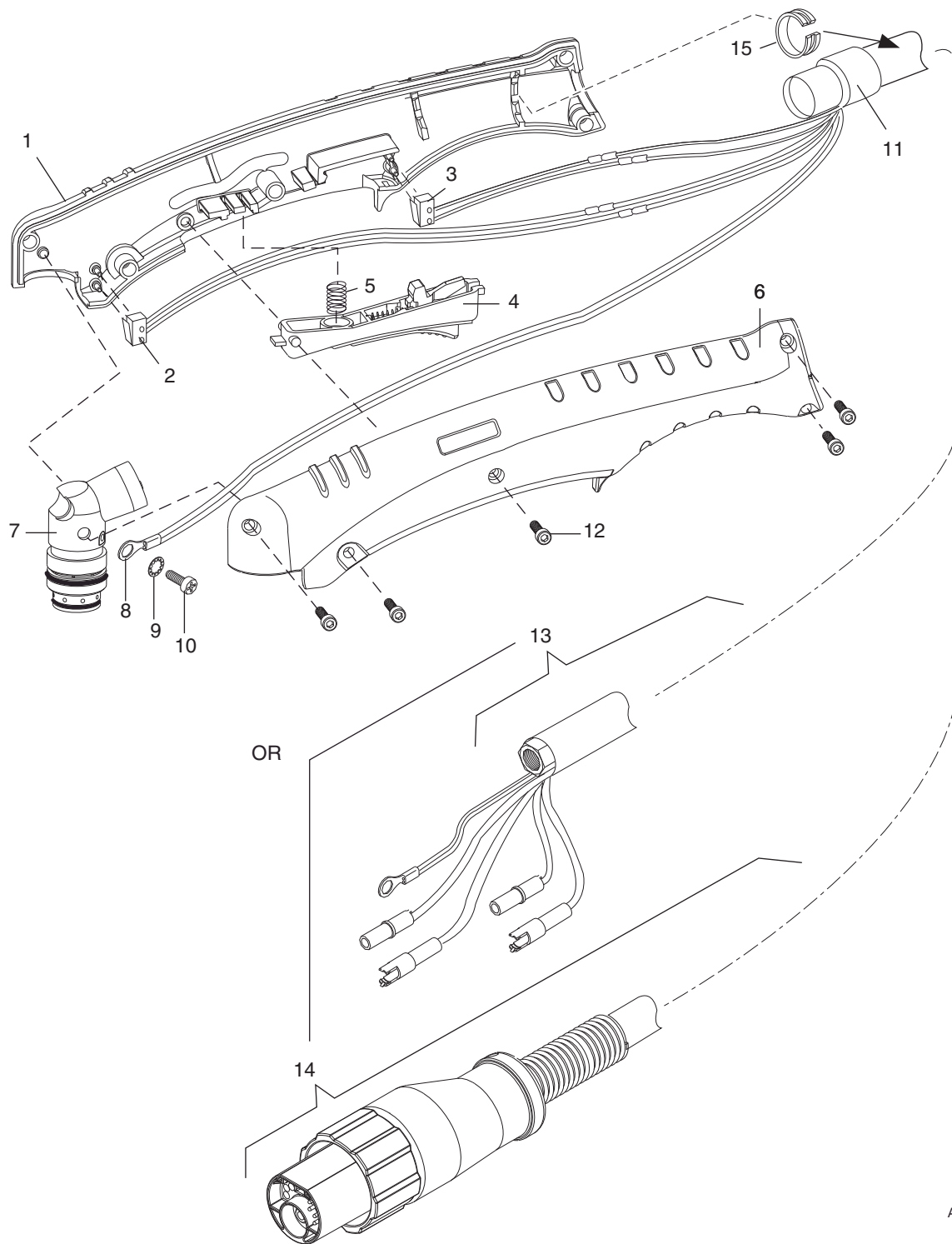

A-03430

- 1 Right Handle Half
- 2 PIP Switch
- 3 Torch Trigger Switch
- 4. Trigger Assembly
- 5 Trigger Return Spring

- 6 Left Handle Half
- 7 Torch Head
- 8 Pilot Lead Terminal
- 9 Internal Star Washer
- 10 Screw

- 11 Torch Lead Fitting
- 12 Handle Screw
- 13 Leads Connection (O2b)
- 14 Leads Connection (ATC)
- 15 Bushing (SL60 Torches only)

**Torch Trigger Replacement Kit
for SL60 & SL100 Hand Torches
Catalog No. 9-7034**

Installation Instructions

General Information

These instructions cover Torch Trigger Replacement Kit No. 9-7034 for Thermal Dynamics Model SL60 and SL100 Plasma Cutting Hand Torches.

The replacement should only be performed by a qualified technician. Thoroughly read the instructions first, before attempting the replacement procedure.

Supplied Parts

The kit includes:

- Trigger Assembly with springs - 1
- Installation Instructions - 1
- Handle Screw Wrench - 1

Replacement Procedures



WARNING

Disconnect primary input power at the source before disassembling the Torch.

A. Torch Disassembly

Disassemble the torch as follows:

1. Remove the shield cup, tip, starter cartridge, and electrode from the torch.
2. Remove 5 screws as illustrated.
3. Lift the left handle half off the assembly and set aside.
4. Note the position of the trigger release. When the trigger release is slid to the rear, an extension at its rearmost end fits between two protrusions on the back end of the trigger. This extension activates the torch control switch.
5. Lift the Trigger Assembly, including the Trigger Return Spring, out of the handle assembly. Leave the Torch Head and Leads Assembly and the switches in place in the right handle half.

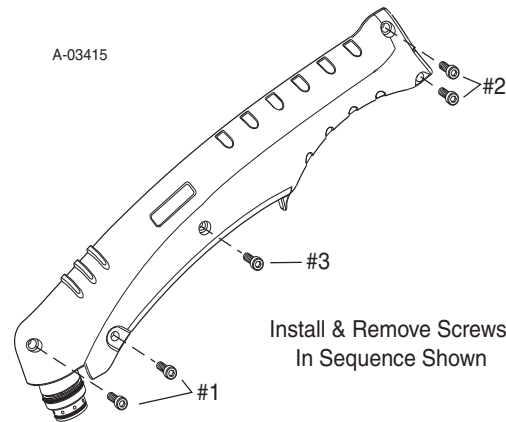

Removing Handle Screws

B. Trigger Replacement

1. The Trigger Assembly includes the trigger release and springs. Refer to the illustration.
2. Check the Trigger Assembly against the illustration. Ensure that the trigger release is fully against the trigger and slides freely along the trigger, and that the springs are in place.
3. Place one end of the trigger return spring in a socket on the upper (inner) surface of the trigger. Position the back end of the replacement Trigger Assembly in the right handle half first. The activating blade of the torch switch fits in a slot on the back end of the torch trigger. Position the trigger pivot in its mating socket in the handle half.
4. Refer to the illustration. Ensure that:
 - The pivot pin of the Trigger Assembly engages the mating socket in the right handle half.
 - The activating blade of the torch switch fits in a slot on the back end of the torch trigger.
 - The trigger assembly closes the torch switch.

C. Torch Assembly

1. Check that wires do not impede the motion of the Trigger Assembly.
2. Position the left handle half against the right half. Adjust as needed to ensure that the pivot pin on the Trigger Assembly engages its mating socket in the left handle half. Hold the Torch Assembly together tightly by hand.
3. Install and tighten all screws. Check to ensure that no wires are pinched between the edges of the handle halves when the screws are tightened fully.

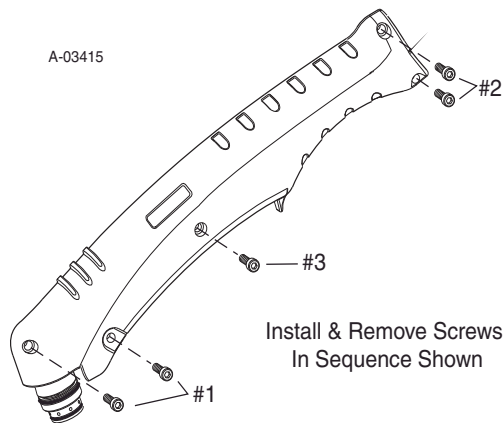

Replacing Handle Screws

4. Test the Trigger Assembly for proper operation.
5. Reconnect the Torch to the Power Supply. Test for proper operation.

NOTE

Every effort has been made to provide complete and accurate information in this manual. However, the publisher does not assume and hereby disclaims any liability to any party for any loss or damage caused by errors or omissions in this Manual, whether such errors result from negligence, accident, or any other cause.

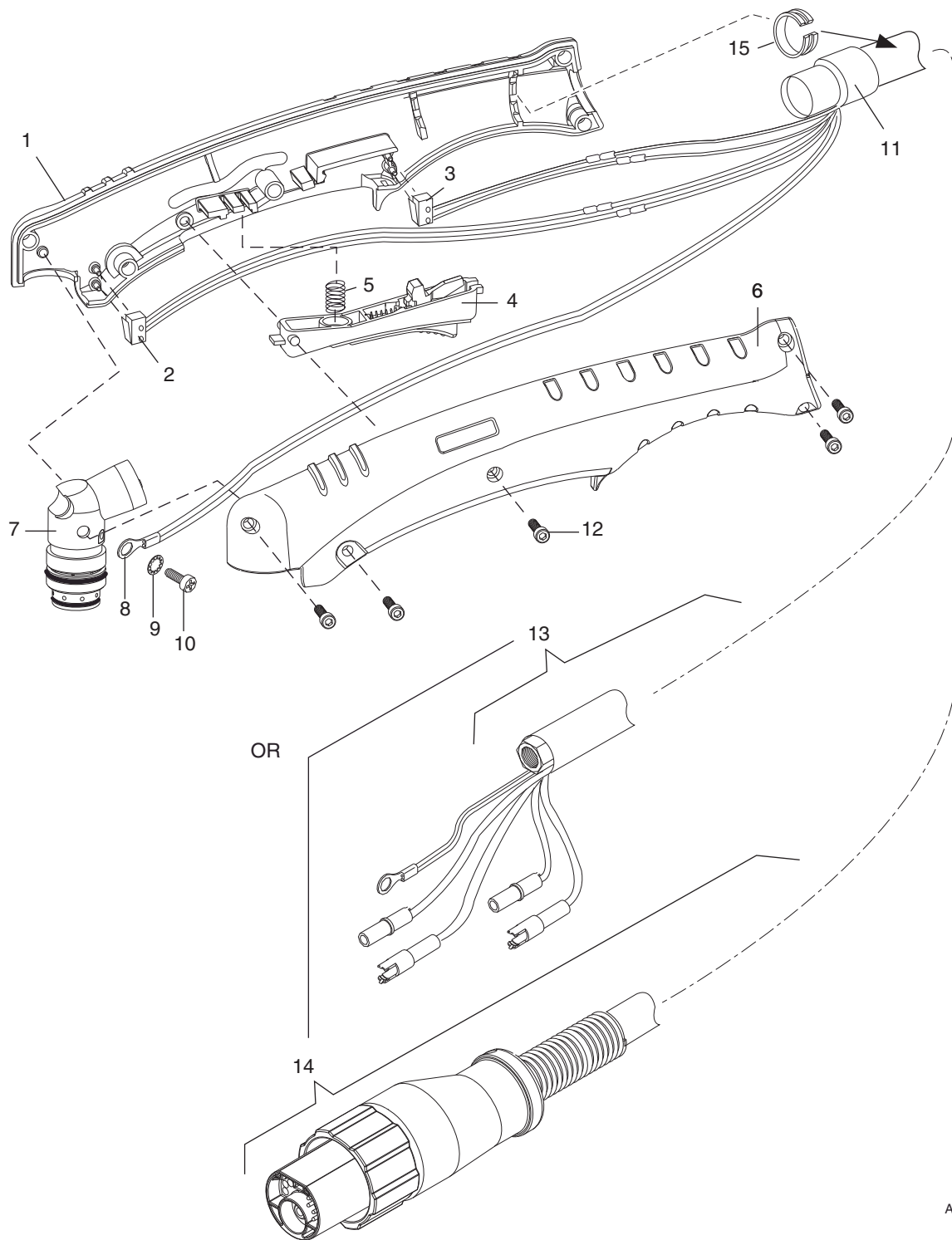

A-03430

- 1 Right Handle Half
- 2 PIP Switch
- 3 Torch Trigger Switch
- 4. Trigger Assembly
- 5 Trigger Return Spring

- 6 Left Handle Half
- 7 Torch Head
- 8 Pilot Lead Terminal
- 9 Internal Star Washer
- 10 Screw

- 11 Torch Lead Fitting
- 12 Handle Screw
- 13 Leads Connection (O2b)
- 14 Leads Connection (ATC)
- 15 Lead Bushing (SL60 leads only)

SL60 and SL100 Hand Torch Replacement Head Kit and Replacement Leads Kits

Installation Instructions

General Information

These instructions cover the following Replacement Kits for Thermal Dynamics Model SL60 and SL100 Plasma Cutting Hand Torches:

- 9-8219 Replacement Torch Head Kit

Replacement Leads Kits:

- 4-7830 SL60 Torch Leads, 20 foot, 02B Connectors
- 4-7831 SL60 Torch Leads, 50 foot, 02B Connectors
- 4-7832 SL100 Torch Leads, 20 foot, 02B Connectors
- 4-7833 SL100 Torch Leads, 50 foot, 02B Connectors
- 4-7834 SL60 Torch Leads, 20 foot, ATC Connectors
- 4-7835 SL60 Torch Leads, 50 foot, ATC Connectors
- 4-7836 SL100 Torch Leads, 20 foot, ATC Connectors
- 4-7837 SL100 Torch Leads, 50 foot, ATC Connectors

The replacement should only be performed by a qualified technician. Read the instructions thoroughly first, before attempting the replacement procedure.

Supplied Parts

The kits include:

Replacement Torch Head Kits:

- Replacement Torch Head - 1
- Phillips Screw - 1
- Internal Star Washer - 1
- Handle Screw Wrench - 1
- Installation Instructions - 1

Replacement Leads Kits:

- Replacement Leads - 1 each
- Handle Screw Wrench - 1 each
- Installation Instructions - 1 each

Replacement Procedures

Disassembly and reassembly of the torch handle is the same for all kits covered by these instructions. Individual replacement steps vary depending on the part being replaced.



WARNING

Disconnect primary input power at the source before disassembling the Torch.

A. Torch Disassembly

Disassemble the torch as follows:

1. Remove the consumables (shield cup, tip, starter cartridge, and electrode) from the torch head. Remove 5 handle screws as illustrated.

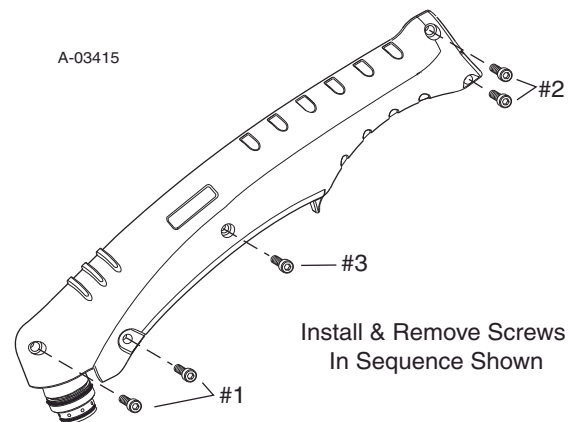

2. Lift the left handle half off the assembly and set aside.
3. Lift the Trigger and Selector Assembly, including the trigger return spring, out of the right handle half.
4. Note the position of the activating blades on the switches. Note the colors of the switch wires.

5. Carefully lift the leads, torch head, and switches out of the right handle half. Set the right handle half aside.
6. Remove the screw and star washer securing the pilot lead to the torch head.
7. Rotate the fitting between the torch head and the torch leads approximately 3 complete revolutions. Pull the torch head away from the fitting to disconnect it from the leads assembly. Set the part being replaced aside.
8. When replacing leads, disconnect the leads from the Power Supply or adapter kit. When replacing SL60 (60 Amp) leads, remove the leads bushing from the leads assembly. Refer to the illustration.

B. Component Replacement

1. When replacing SL60 (60 Amp) leads, transfer the leads bushing to the replacement leads assembly.
2. Position the Torch Head against the Torch Leads connector fitting. Press the Torch Head onto the fitting. The fitting will click. Do not use thread sealant.
3. Rotate the Leads connector fitting by hand to connect Torch Head to the leads. The fitting will stop when it is fully seated against the Torch Head. Do not use tools to tighten this fitting.
4. Use a Phillips screw and an internal star washer to connect the pilot lead to the Torch Head.
5. Position the switches in the right handle half. Note the position of the activating blades on the switches. The arrangement of wire colors must match the original arrangement as noted during disassembly.
6. Position the leads and head assembly in the right handle half. Splices on the torch switch wires fit into a recess on the inside of the right handle half. For SL60 Torches, position the bushing as shown on the leads, to engage the mating rib in the torch handle.
7. The Trigger Assembly includes the Selector and springs. Check the Assembly against the illustration. Ensure that the selector is fully against the trigger and slides freely along the trigger, and that the springs are in place.
8. Position the replacement Trigger Assembly, including the trigger return spring, in the replacement right handle half. The trigger return spring

engages a socket on the upper (inner) surface of the trigger. Put the back end of the Assembly in place first. Ensure that the activating blade of the torch trigger switch fits into the slot on the back end of the Trigger.

9. Refer to the illustration. Ensure that:
 - The pivot pin of the trigger engages the mating socket in the right handle half.
 - The activating blade of the torch switch fits in the slot on the back end of the torch trigger.
 - Wires do not impede the motion of the Trigger Assembly.

C. Reassembly

1. Position all wires to avoid pinching when the handle hardware is secured.
2. Position the left handle half against the right half. Adjust as needed to ensure that the pivot pin on the Trigger Assembly engages its mating socket in the left handle half. Hold the Torch Assembly together tightly by hand.
3. Check to ensure that no wires are pinched between the edges of the handle halves. Install and tighten all screws.

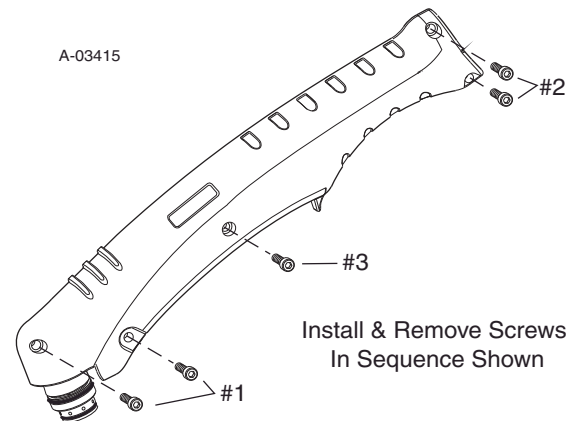

4. Reinstall the consumables. Connect the Torch to the Power Supply. Test for proper operation.

NOTE

Every effort has been made to provide complete and accurate information in this manual. However, the publisher does not assume and hereby disclaims any liability to any party for any loss or damage caused by errors or omissions in this Manual, whether such errors result from negligence, accident, or any other cause.

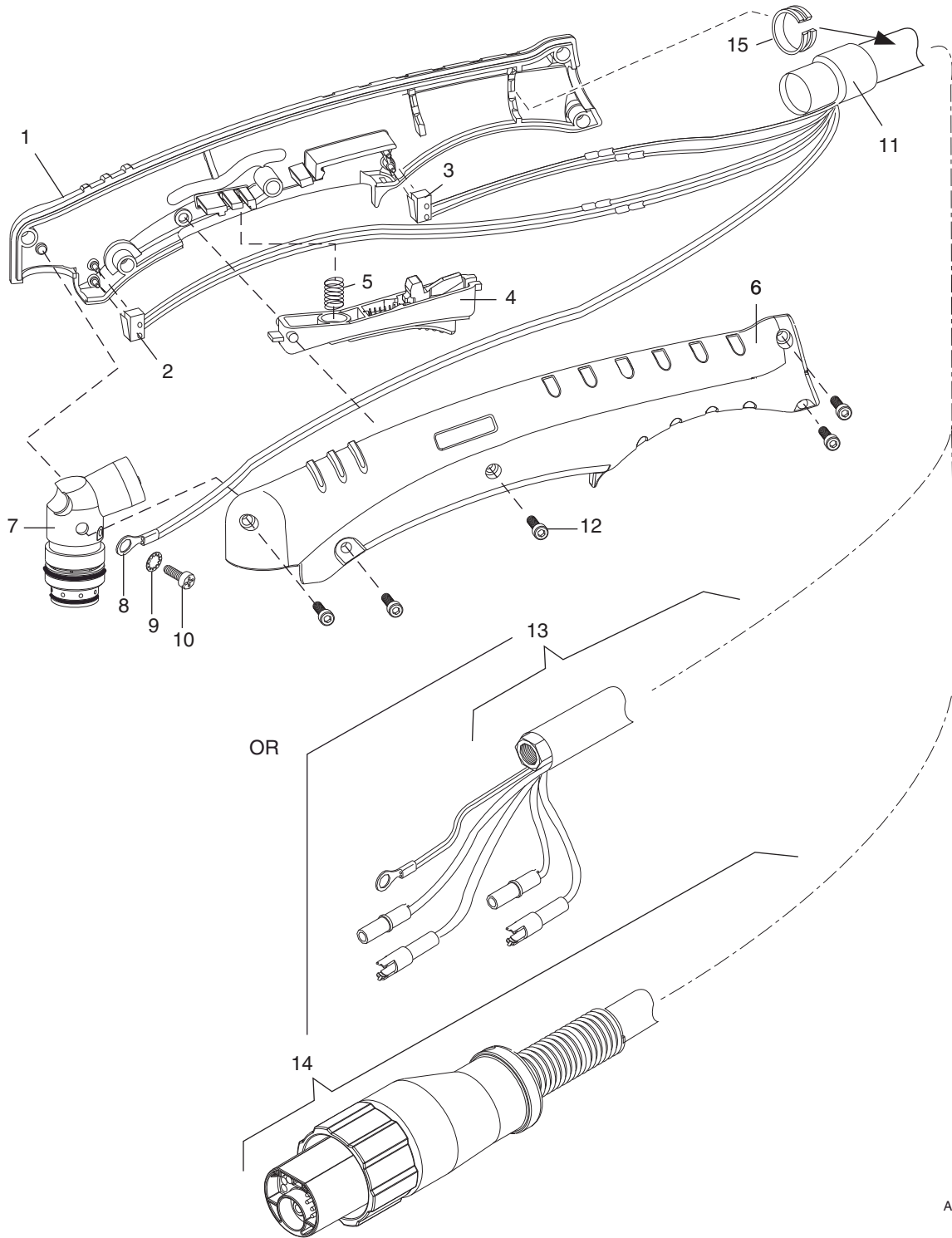

A-03430

- 1 Right Handle Half
- 2 PIP Switch
- 3 Torch Trigger Switch
- 4. Trigger Assembly
- 5 Trigger Return Spring

- 6 Left Handle Half
- 7 Torch Head
- 8 Pilot Lead Terminal
- 9 Internal Star Washer
- 10 Screw

- 11 Torch Lead Fitting
- 12 Handle Screw
- 13 Leads Connection (O2b)
- 14 Leads Connection (ATC)
- 15 Leads Bushing (SL60 leads only)

Replacement Machine Torch Head or Leads Kits

Installation Instructions

General Information

These instructions cover Replacement Torch Head or Replacement Leads Kits for Thermal Dynamics 1Torch Model SL100 Plasma Cutting Machine Torches.

The replacement should only be performed by a qualified technician. Read the instructions thoroughly first, before attempting the installation of the kit.

Supplied Parts

Replacement Torch Head Kit includes:

- Torch Head Assembly, including PIP plunger and return spring
- Tie Wrap
- Installation Instructions

Replacement Leads Kits include:

- Torch Leads Assembly - configured as ordered
- Tie Wrap (Automated / Shielded Leads only)
- Installation Instructions

Replacement Procedures



WARNING

Disconnect primary input power at the source and bleed down the system before disassembling the Torch.

A. Disassembling Torch

Disassemble the torch as follows:

1. Remove the torch consumables (shield cup assembly, tip, starter cartridge, and electrode).

Refer to the illustration. **For torches with shielded leads only**, remove the tie wrap securing the leads cover to the positioning tube end cap. Slide the leads cover back far enough to expose the positioning tube end cap.

2. Remove the end cap assembly from the top of the positioning tube.
3. Release the hardware securing the positioning tube to the support (pinch block or pinion) assembly. Ensure that the positioning tube is free to rotate within the support assembly.
4. Hold the Torch Head stationary. Rotate the positioning tube to release the torch head from the positioning tube.

NOTE

The torch head must remain stationary while the positioning tube is rotated, to avoid twisting the torch leads within the positioning tube.

5. Pull the Torch Head Assembly straight down from the positioning tube, far enough to expose the torch leads connections to the torch head assembly.

B. Removing Torch Head

1. Refer to the illustration. Note the positioning of the pilot lead terminal on the Torch Head. Disconnect the pilot lead wire terminal from the torch head.
2. Note the positioning of the PIP switch on the torch head. Pull the PIP switch straight away from the torch head. Leave the switch connected to the leads.
3. Hold the PIP plunger and return spring in position on the torch head assembly. Hold the torch head assembly stationary. Rotate the leads connector fitting on the top of the torch head by hand to disconnect the leads from the head.
4. Set the torch head aside.
5. **If replacing the torch leads**, pull the original leads assembly straight out through the top of the positioning tube. Disconnect the torch leads from the power supply, either at the power supply bulkhead, the power supply ATC console receptacle, or the ATC Adapter.

C. Installing Replacement Parts

Install the replacement component as follows:

1. **If replacing the torch leads**, pass the torch end of the replacement leads through the positioning tube. Connect the power supply end of the leads assembly to the power supply bulkhead, the power supply ATC console receptacle, or the ATC Adapter.
2. Press the torch head assembly onto the leads connector fitting. The connector fitting should click twice. Thread the connector fitting onto the torch head assembly by rotating the fitting until the parts seat together fully. Do not use thread sealant. Do not use tools to tighten the fitting. If resistance is felt, pull the connection apart, realign the connector fitting with the torch head, and press the parts together.
3. Connect the pilot lead wire to the torch head, with the lead terminal positioned as noted previously.
4. Fit the PIP switch onto the mounting pins on the Torch Head Assembly, with the switch positioned as noted previously.
5. Press the PIP plunger into the Torch Head to ensure proper operation of the PIP switch.
6. Hold the Torch Head stationary. Rotate the positioning tube to secure the torch head to the positioning tube.

NOTE

The torch head must remain stationary while the positioning tube is rotated, to avoid twisting the torch leads within the positioning tube.

7. Secure the positioning tube to the support (pinch block or pinion) assembly with the hardware removed previously.
8. Install the end cap assembly on the positioning tube. On unshielded leads, the end cap assembly must capture and position the bend relief.
9. **For shielded leads**, slide the end of the leads cover over the positioning tube end cap. Secure the leads cover in place with the tie wrap included in this kit.
10. Reinstall the torch consumable parts (shield cup, tip, starter element, and electrode). Reconnect primary input power and the gas supply. Test the torch for proper operation.

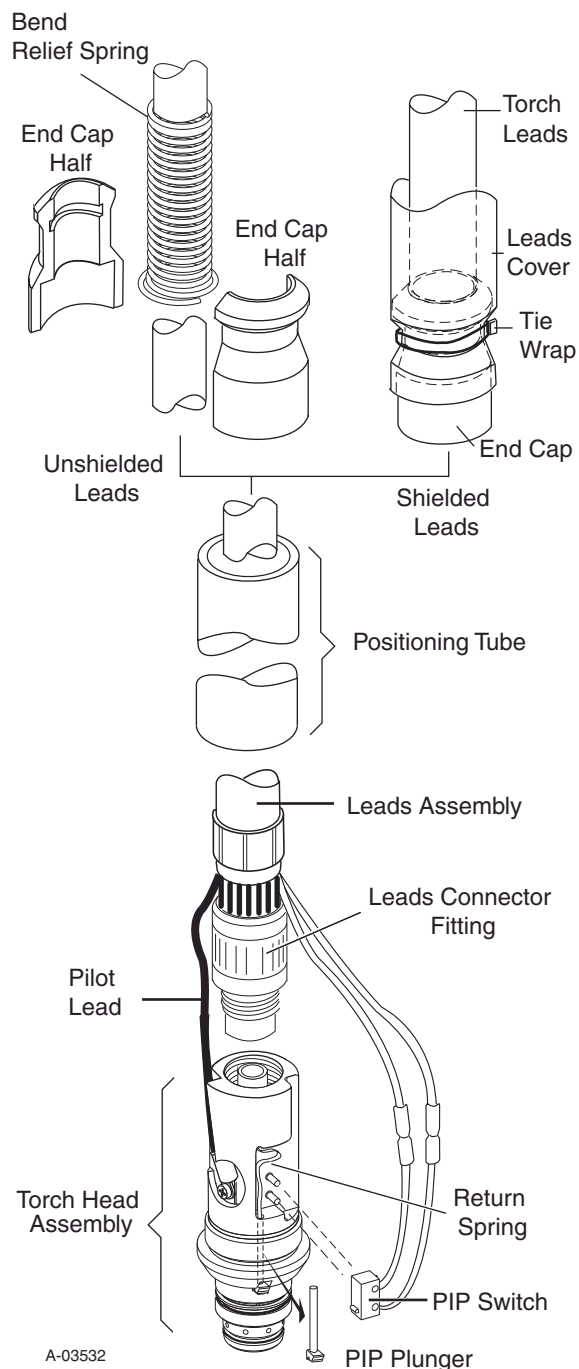

NOTE

Every effort has been made to provide complete and accurate information in this manual. However, the publisher does not assume and hereby disclaims any liability to any party for any loss or damage caused by errors or omissions in this Manual, whether such errors result from negligence, accident, or any other cause.

Replacement Switch Kit Catalog #9-7036

Installation Instructions

General Information

These instructions cover the replacement PIP switch kit for Thermal Dynamics Model SL100 Machine Torches. Read and follow these instructions for proper installation.

Supplied Parts

The kit includes:

- Switch Assembly with Wires and Butt Splices
- Shrink Tubing
- Instructions

Procedure



WARNING

Only a qualified technician should perform this procedure.

Disconnect primary power at the source before performing any inspection or repairs.

Disconnect the gas supply line and bleed down the system.

A. Preparation

1. Remove the consumables from the torch head. Loosen hardware securing the pinion assembly to the mounting tube.
2. Refer to the illustration. Loosen the end cap at the top of the mounting tube. Slide the cap off the mounting tube.
3. Hold the torch head assembly stationary. Rotate the mounting tube to disconnect the tube from the torch head.

B. Switch Removal and Replacement

1. Cut the original switch wires above the butt splices and as close as possible to the butt splices. Remove any remaining pieces of insulating sleeving on the wires.
2. Note the position and orientation of the switch and the switch return spring on the torch head assembly. Hold the switch return spring in place on the torch head assembly. Slide the switch off the mounting pins on the torch head assembly.
3. Strip approximately 1/4" / 6mm of insulation from the switch wires on the leads assembly.
4. Cut the shrink tubing provided in this kit in half. Slide the halves of the tubing onto the replacement switch wires.
5. Crimp the switch wires on the leads assembly to the butt splices on the replacement switch assembly.
6. Position the shrink tubing halves over the butt splices. Use a heat gun to shrink the tubing onto the butt splices.
7. Position the switch assembly on the torch head assembly, matching the orientation of the original switch.
8. Press the head of the switch plunger upward to test the plunger and switch for proper operation.
9. Position the torch switch wires in the notch in the torch head.

C. Torch Reassembly

1. Hold the torch head assembly stationary. Rotate the mounting tube to connect the tube to the torch head. Tighten securely.
2. Position the mounting tube to engage the pinion assembly. Tighten the hardware securing the pinion assembly to the mounting tube.
3. Slide the end cap into position on the top of the mounting tube. Secure the end cap.
4. Reinstall the consumables on the torch head.

NOTE

Every effort has been made to provide complete and accurate information in this manual. However, the publisher does not assume and hereby disclaims any liability to any party for any loss or damage caused by errors or omissions in this Manual, whether such errors result from negligence, accident, or any other cause.

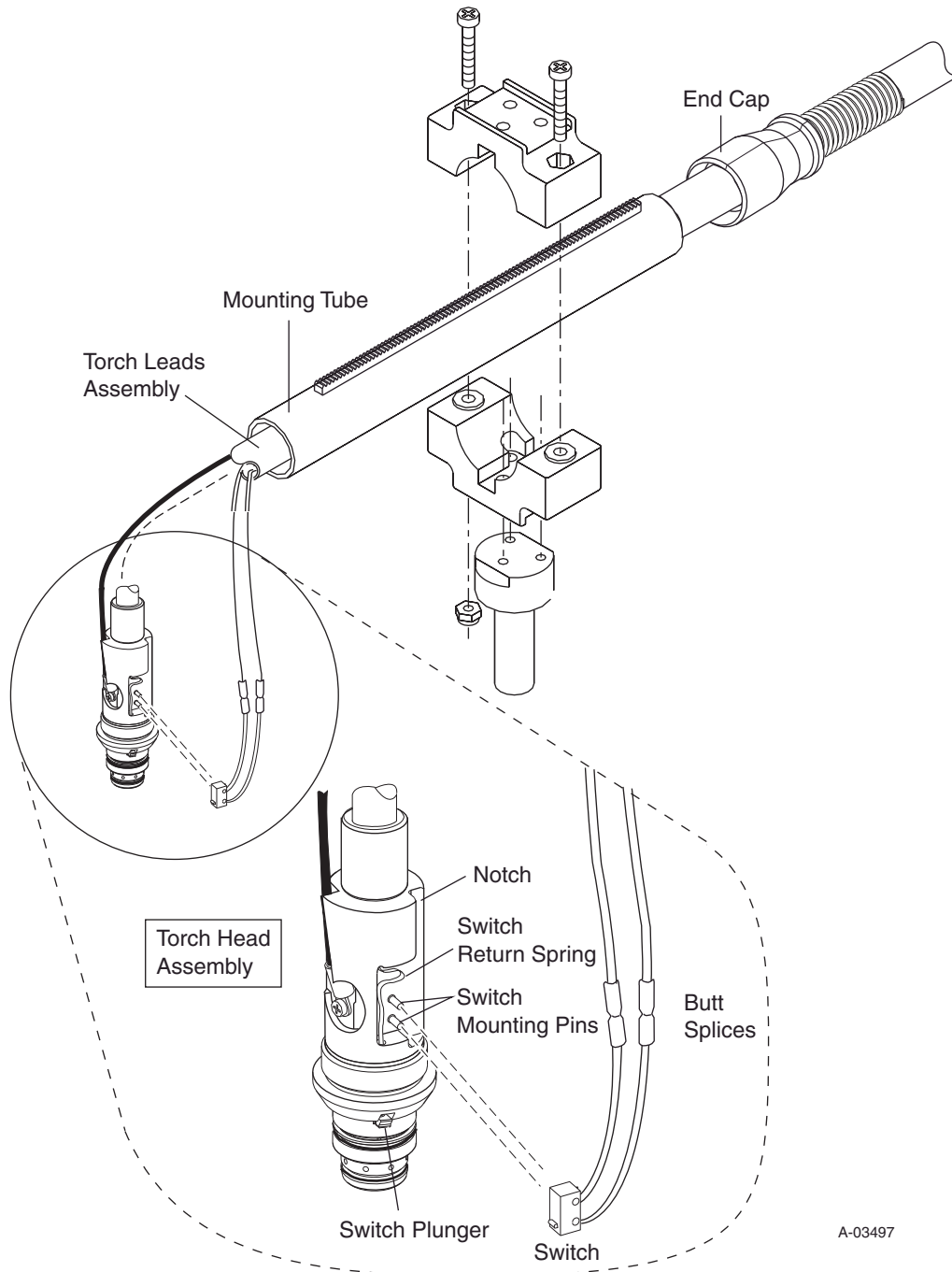

A-03497

Replacement PIP Plunger & Spring Kit, No. 9-7045

Installation Instructions

General Information

These instructions cover the Replacement PIP Plunger and Spring Kit for Thermal Dynamics 1Torch Model SL100 Plasma Cutting Machine Torches.

The replacement should only be performed by a qualified technician. Read the instructions thoroughly first, before attempting the installation of the kit.

Supplied Parts

The Kit includes:

- PIP Plunger and Return Spring
- Installation Instructions

Replacement Procedures



WARNING

Disconnect primary input power at the source and bleed down the system before disassembling the Torch.

A. Disassembling Torch

1. Remove the torch consumables (shield cup, tip, starter cartridge, and electrode).
2. Refer to the illustration. Remove the end cap assembly from the top of the positioning tube.
3. Release the hardware securing the positioning tube to the support (pinch block or pinion) assembly. Ensure that the positioning tube is free to rotate within the support assembly.
4. Hold the Torch Head stationary. Rotate the positioning tube to release the torch head from the positioning tube.

NOTE

The torch head must remain stationary while the positioning tube rotates, to avoid twisting the torch leads within the positioning tube.

5. Pull the Torch Head Assembly straight down from the positioning tube, far enough to expose the PIP return spring and PIP Switch on the torch head assembly.
6. Note the position of the PIP Switch on the torch head. Pull the PIP switch assembly away from the Torch Head. Leave the assembly connected to the leads.
7. Note the position of the PIP return spring. Lift the PIP return spring away from the Torch Head. Set the spring aside.
8. Note the position of the PIP Plunger. Grasp the lower end of the PIP Plunger with a needle-nose pliers or similar tool. Pull the lower end of the plunger away from the torch head assembly and downward at the same time. Remove the PIP Plunger from the Torch Head.

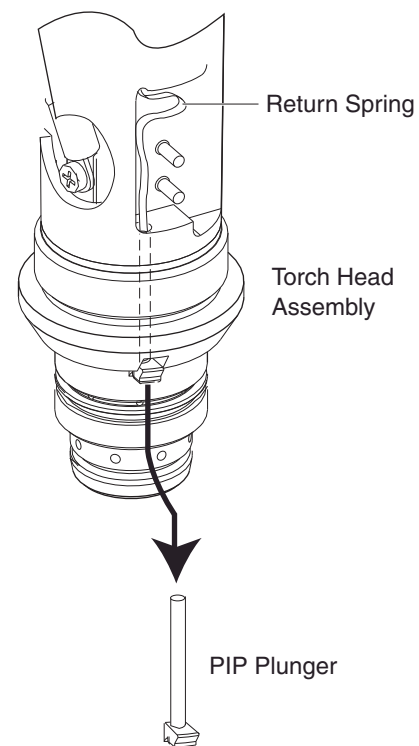

A-03534

B. Installing Replacement Parts

1. Press the replacement plunger into the torch head. Push it up as far as it will go, so that the notch in the torch head keeps the plunger in position.
2. Fit the replacement return spring onto the torch head.
3. Install the PIP Switch on its mounting pins on the Torch Head Assembly, with the switch positioned as noted previously.
4. Press the PIP plunger into the Torch Head to ensure proper operation of the PIP switch.

C. Assembling Torch

1. Hold the Torch Head stationary. Rotate the positioning tube to secure the torch head to the positioning tube.

NOTE

The torch head must remain stationary while the positioning tube rotates, to avoid twisting the torch leads within the positioning tube.

2. Secure the positioning tube to the support (pinch block or pinion) assembly with the hardware removed previously.
3. Install the end cap assembly on the positioning tube. The cap end assembly must capture and position the bend relief spring.
4. Reinstall the torch consumable parts (shield cup, tip, starter element, and electrode). Reconnect primary input power and the gas supply. Test the torch for proper operation.

NOTE

Every effort has been made to provide complete and accurate information in this manual. However, the publisher does not assume and hereby disclaims any liability to any party for any loss or damage caused by errors or omissions in this Manual, whether such errors result from negligence, accident, or any other cause.

