

Origo™ Vac Cart

Origo™ Vac Cart mobile unit for light welding and extraction applications. Origo™ Vac Cart includes Extraction Arm with an integrated spotlight, which optimizes the user-friendly design.

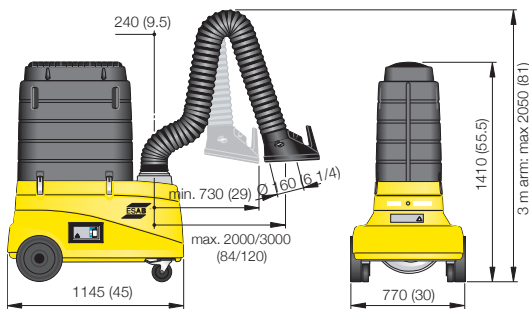

mm (inch)
Horizontally swivelling arm



Arm length m	Arm Ø, mm	Max. airflow, m ³ /h	Filter efficiency, %	Filter area, m ²	Voltage, V/ electrical plug	Power, kW	Frequency, Hz	Phase	Noise level, dB(A)	Weight, kg	Part no.
3	160	1050	99	35	230/EUR	0.75	50	1	73	73	0700 003 034
3	160	1050	99	35	240/UK	0.75	50	1	73	73	0700 003 035
3	160	1050	99	35	US/CAN	0.75	50	1	73	73	0700 003 037

Accessories	Part No.
HEPA filter H13, 7.5 m ² high efficiency final filter, class H13.	0700 003 219
Spark protection, for mounting in the hood. To reduce risk of fire.	0700 003 217

Replacement filter	Part No.
35m ² flame retardant pleated cellulose material. = 99% efficiency for welding fume. Measured according to the test procedures in EN 15012-1.	0700 003 220