

Origo™ Vac Arm HD

The Origo™ Vac Arm HD extraction arm is the top of the range arm when it comes to high airflows and extraction of media with higher temperatures than normal. The arm is specially designed for working environments with very heavy smoke, vapours or non explosive dust. The applications can be welding, laser or hand plasma cutting, metal spraying, grinding where lots of spatter is generated, or other industrial processes where a perfectly balanced and easily positioned arm is required.

- Robust swivel, which allows the product to rotate 360°
- Support mechanism of the arms is encapsulated which protects against dirt
- Equipped with a damper in the hood as standard
- The hose is easy to remove for cleaning
- Minimized pressure drop and a low noise level



Pressure drop

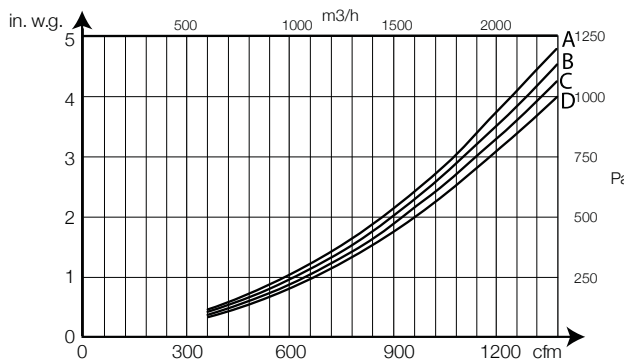

A: 5 m (16 1/2 ft.), B: 4 m (14 ft.), C: 3 m (10 ft.), D: 2 m (7 ft.)

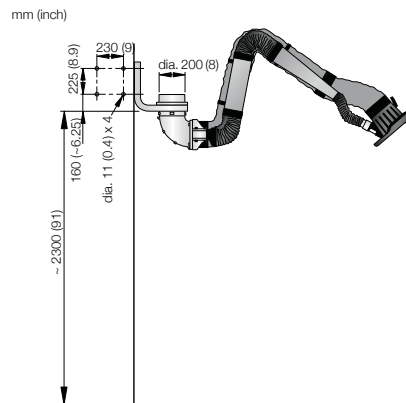

Description	Reach, m (ft.)	Airflow, m ³ /h (cfm)	Connection Ø, mm (in.)	Max. fume temperature, °C (°F)	Noise level at hood, dB(A)	Weight, kg (lb.)	Part no.
Origo™ Vac Arm HD 3m (10 ft.)	3 (10)	1000-1900 (600-1100)	200 (8)	120 (250)	63	21 (46)	0700 003 030
Origo™ Vac Arm HD 4m (14 ft.)	4 (14)	1000-1900 (600-1100)	200 (8)	120 (250)	63	28 (62)	0700 003 031